



## Facility Decommissioning Evaluation Building 484-5D, D-Area Powerhouse Storage Building

This is a Simple Model Decommissioning per Facility Disposition Manual 1C

Prepared by:  Date: 9/29/20  
J. K. Blankenship  
EC&ACP Engineering  
Environmental Compliance and Area Completion Projects

Reviewed by:  Date: 9/29/2020  
William B. Griffin  
EC&ACP Engineering  
Environmental Compliance and Area Completion Projects

Approved:  Date: 09-29-2020  
Manuel I. Terronez  
EC&ACP Engineering Manager  
Environmental Compliance and Area Completion Projects

Approved:  Date: 9/29/20  
C.J. Ward  
EC&ACP Operational Compliance Manager  
Environmental Compliance and Area Completion Projects

Approved:  Date: 9/29/2020  
R. Steven Shirley  
Manager, EC&ACP Projects  
Environmental Compliance and Area Completion Projects

Approved:  Date: 9-30-2020  
T.O. Oliver  
EC&ACP Chief Engineer  
Environmental Compliance and Area Completion Projects



## DISCLAIMER

**This document was prepared in conjunction with work accomplished under Contract No. DE-AC09-08SR22470 with the U.S. Department of Energy.**

**This work was prepared under an agreement with and funded by the U.S. Government. Neither the U.S. Government or its employees, nor any of its contractors, subcontractors or their employees, makes any express or implied: 1. warranty or assumes any legal liability for the accuracy, completeness, or for the use or results of such use of any information, product, or process disclosed; or 2. representation that such use or results or such use would not infringe privately owned rights; or 3. endorsement or recommendation of any specifically identified commercial product, process, or service. Any views and opinions of authors expressed in this work do not necessarily state or reflect those of the United States Government, or its contractors, or subcontractors.**

**Printed in the United States of America**

*Prepared for*  
**U. S. Department of Energy**  
*and*  
**Savannah River Nuclear Solutions LLC**  
**Aiken, South Carolina**

## Introduction

This document contains an evaluation of available existing information about a facility that is slated for decommissioning. This evaluation screens the project to determine whether it is appropriate to conduct the decommissioning under the Comprehensive Environmental Response, Compensation, and Liability Act (CERCLA), or to use a simpler graded approach.

This Facility Decommissioning Evaluation (FDE) consists of three sections. Part 1 contains a description of the project scope, including a brief summary of the purpose and history of the facility and photographs of the structures that are part of the project. Part 2 encompasses a series of questions, the answers to which determine the decommissioning model, (CERCLA Model, Integrated Sampling Model, or Simple Model) that will be used. The three graded approach models are described in Facility Disposition Manual 1C, Procedure 501. Part 2 also includes a justification for the answers to each question. Part 3 is a list of references that were used for the evaluation.

## Conclusion

A review of the existing characterization data, process/building history, sample data and walk downs of the facility supports the determination that this building and its ancillary structures meet the criteria of a Clean Building, Simple Model as described in Facility Disposition Manual 1C, Procedure 501. This decision is supported by the documentation found throughout the body of this document. No chemical or hazardous radioactive contaminants are associated with this structure.

## Part 1. Project Scope

### Scope

This Evaluation has been prepared in accordance with requirements found in Facility Disposition Manual 1C; Procedure 502, "Preparing Decommissioning Decision Documents. The scope of this evaluation includes buildings and ancillary structures which are further described in the next section:

484-5D, D-Area Powerhouse Storage Building has no ancillary structures.

The proposed decommissioning end-state for this facility is demolition to the building slab.

The described decommissioning activities are not the final area closure actions. The decommissioning of a building is intended to reduce landlord costs, increase safety by removing excess facilities and reduce the potential for releases of hazardous substances to the environment.

## Facility Description

Building 484-5D was erected on site circa 1980. The structure is an aluminum tube-frame structure with a corrugated aluminum skin. The structure is attached to a concrete slab. The structure itself is approximately 12' X 30', with a non-partitioned interior. The structure has double, swinging doors at its front for access. Refer to Figure 1 for a picture of the structure, Figure 2 for a layout of the structure, and Figure 3 for surrounding structures.



Figure 1. Building 484-5D Powerhouse Storage Building

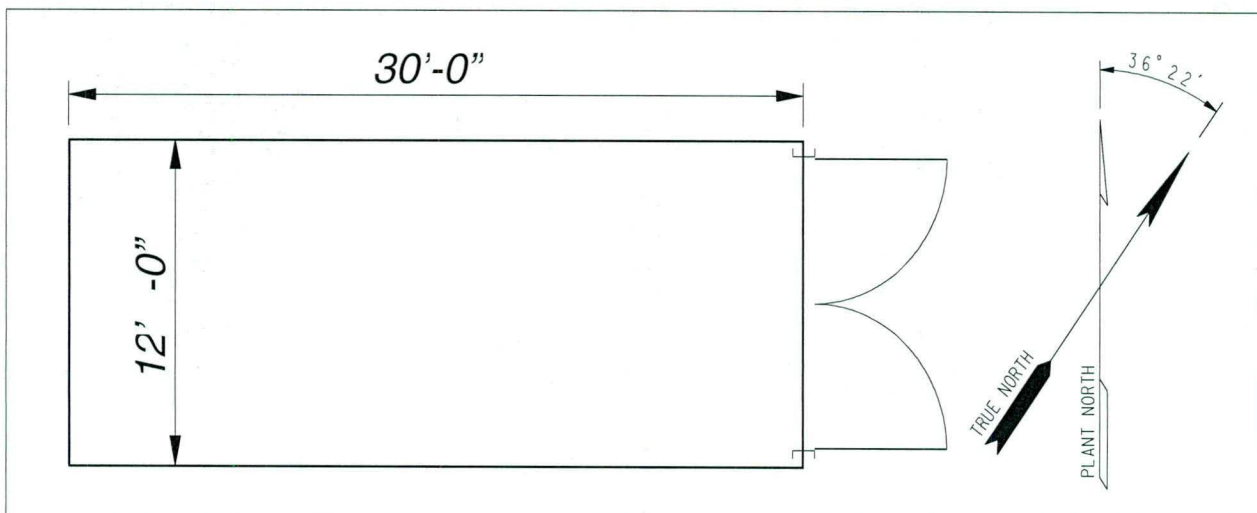
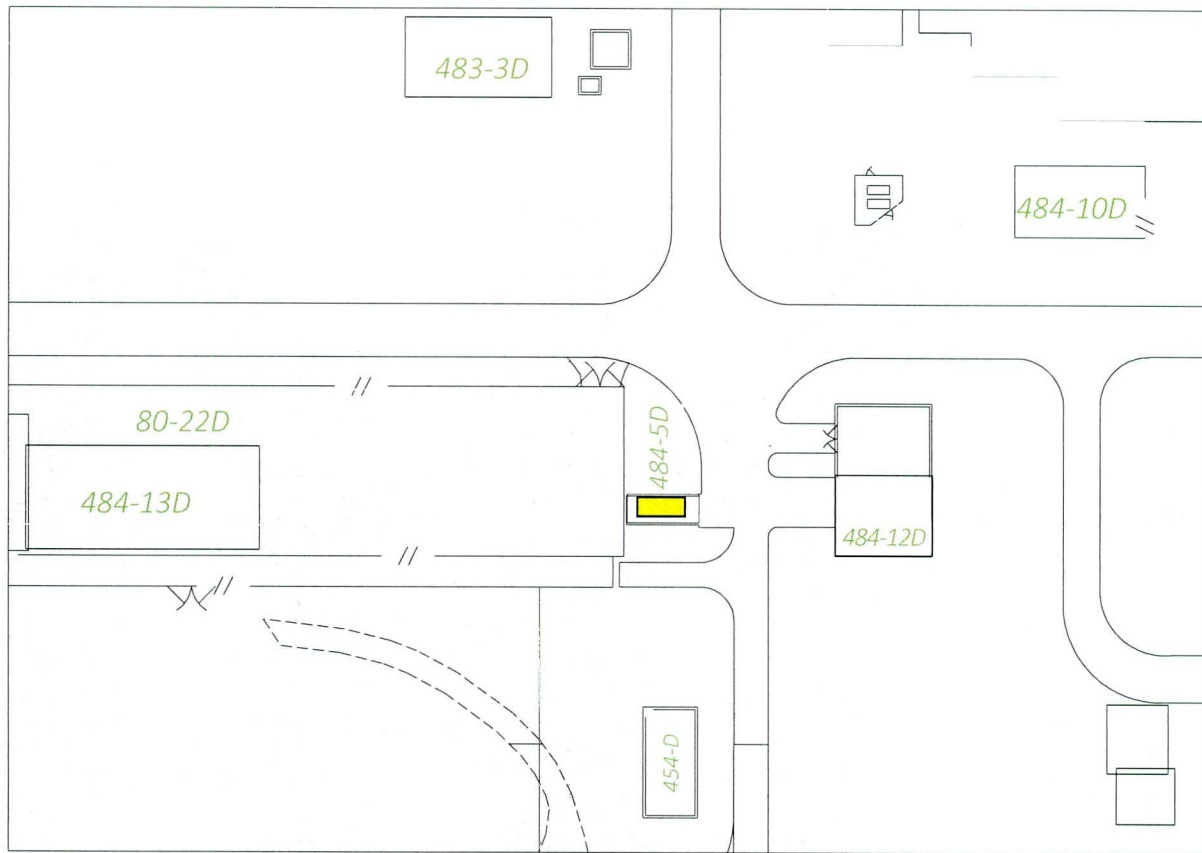

Figure 2. Building 484-5D, Storage Building (Layout)



**Figure 3. Building 484-5D, Storage Building Area (Layout/Location)**

### Process History

Review of records, walkdowns and interviews indicate that no chemical or radioactive processes were performed in this building (i.e., no chemical, mechanical or electrical energy or interaction was performed to change the state of the input material or to produce a new output product).

Historically, the 484-5D Building was used for storage of miscellaneous construction equipment/materials for the 484-D powerhouse. The structure has no utilities serving it. The following list is representative of the items once stored within the structure, but may not be all inclusive:

- Gasoline (5-gallon cans)
- Motor oil (quart containers)
- Flexible Hoses
- Drum pumps
- Fall protection equipment
- Lifting and hoisting equipment
- Tools
- Fasteners
- Scaffolding
- Welding leads
- Welding helmets
- Welding gloves
- Portable lighting
- Flexible exhaust ducting
- Portable generators
- Powered personnel cooling systems
- Insulation

There is no evidence of spills onto the concrete slab within the walls of the structure, only rust stains. There is no evidence of spill material exterior to the structure. The structure has no history of chemical processes being performed within the structure. Stained concrete will be cleaned with a strong surfactant, BioSolve<sup>®</sup>, or equivalent cleaning agent. There are no sumps or drains in the structure. The concrete slab appears to be in good condition with exception of a minor, tight crack running across the slab.

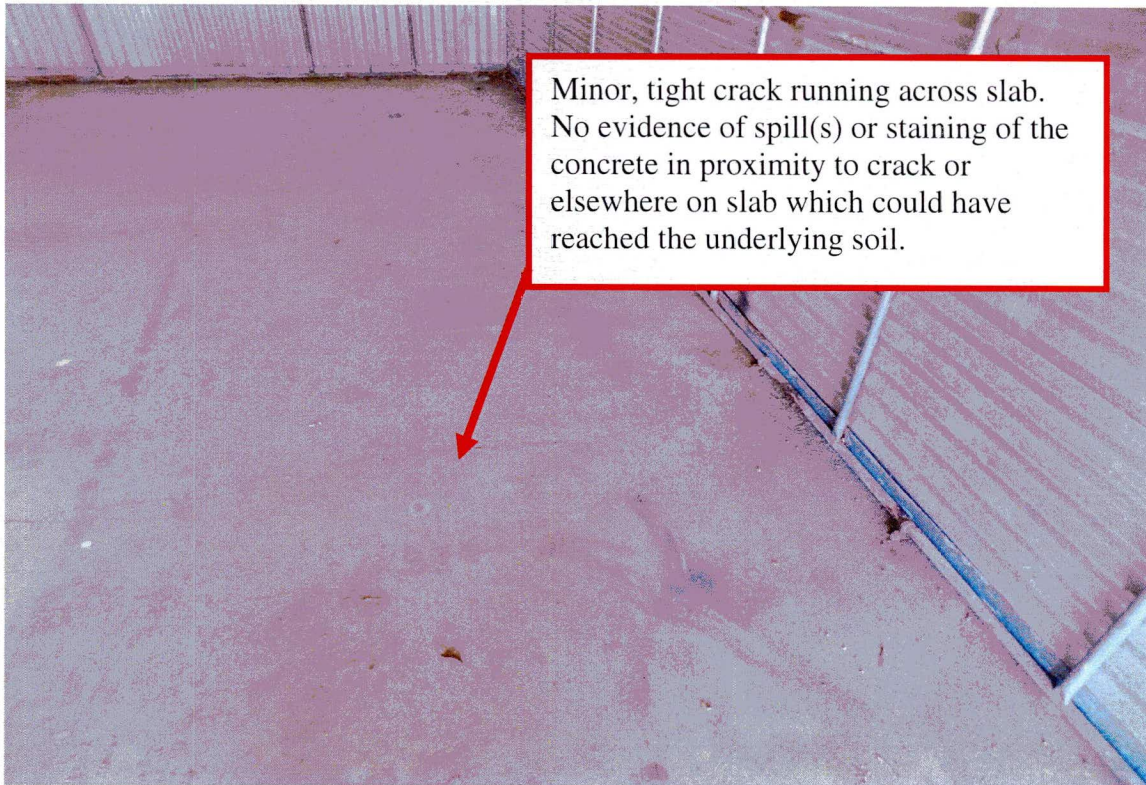

Figure 4. Inside Building 484-5D (Looking West)

**Chemical Process**

Chemical Name	Process Location	Evidence of Spills?
N/A	N/A	N/A

**Radioactive Process**

Isotope	Contaminated Areas/Others
N/A	N/A

## Summary of Existing Characterization

Characterization has been accomplished using a combination of process knowledge/historical release information, verification walk downs and sampling as appropriate.

An important part of the characterization portion of this evaluation is a historical review of spills/releases to the environment. This review includes a review of the Occurrence Reporting and Processing System/ Site Item Reportability and Issue Management (ORPS/SIRIM) database (Reference 2) conducted from the effective date of the Federal Facility Agreement (FFA), August 16, 1993 to present and a review of the FFA (Reference 1). The FFA serves as a review of releases/spills to the environment prior to August 16, 1993. Review of the FFA, the SRS ORPS/SIRIM database and SRS spill files reveals no records of spills having occurred at the 484-5D structure.

An asbestos survey of the building was conducted on November 4, 2019, which identified a small amount of Asbestos Containing Material (ACM). The results of that survey are included in Q-APG-D-00007, Baseline Asbestos Inspection Report of Building 484-5D (Reference 5). In accordance with 40 CFR part 61.145, a ten-day notification will be filed with South Carolina Department of Health and Environmental Control (SCDHEC) prior to demolition and all ACM removal will be performed by asbestos trained personnel with proper permitting and waste disposal procedures.

Wastes generated during decommissioning will be characterized and managed in accordance with Savannah River Site (SRS) procedures and State and Federal regulations.

## Historical Significance

A review has been conducted in accordance with a Programmatic Agreement. This review resulted in the publication of a Cultural Resources Management Plan (Reference 3) in which the facilities with historical significance are listed. This facility is not listed in that reference and therefore is not historically significant.

## Part 2. Evaluation

Clean Facilities				
	Question	Yes	No	Justification
1.	Has the facility ever contained or processed radioactive or hazardous material other than stored packaged material or materials of construction?  <i>If yes, go to question 4.</i>		X	Facility is a standard storage structure. There is no evidence that radioactive or hazardous material was stored or processed within the structure (Reference 4). None of the available information or personnel interviews indicate the structure has been used for anything except storage.
2.	If there was stored packaged material, has there ever been a spill? <i>If No or N/A, this is a Simple Model. Stop.</i>		X	The only staining on the slab appears to be rust staining. The stained concrete will be cleaned with BioSolve® or equivalent surfactant prior to completion of decommissioning. <b>Decommissioning of Building 484-5D will be performed as a Simple Model decommissioning.</b>
3.	Was spill confined inside structure and cleaned to free release standard per Radiological Control Manual 5Q (for radiological) or continued occupancy per Industrial Hygiene Manual 4Q (for hazardous)? <i>If Yes, this is a Simple Model. Stop.</i>			
Contaminated Facilities				
	Question	Yes	No	Justification
4.	Is the facility listed as a RCRA/CERCLA Unit in Appendix C of the SRS FFA? <i>If Yes, this is a CERCLA Model. Stop.</i>			
5.	Is the facility listed as a Site Evaluation Area in Appendix G of the SRS FFA? <i>If Yes, this is a CERCLA Model. Stop.</i>			
6.	Is there evidence that there has been a release of hazardous or radioactive materials outside the structure? <i>If Yes, this is a CERCLA Model. Stop.</i>			
7.	Is there a substantial threat of a release of hazardous or radioactive materials outside the structure? <i>If Yes, this is a CERCLA Model. Stop.</i>			
8.	Has the facility been assigned a hazard category as defined in Facility Safety Document Manual 11Q? <i>If No, stop and refer facility for evaluation to assign a hazard category, then proceed</i>			
9.	Is the hazard category Nuclear (HC- 2 or 3), radiological, or high hazard chemical? <i>If Yes, this is a CERCLA Model. Stop</i>			

<b>Contaminated Facilities (cont'd)</b>				
	<b>Question</b>	<b>Yes</b>	<b>No</b>	<b>Justification</b>
10.	Has the Department of Energy-Savannah River directed that the decommissioning be performed using the CERCLA Model? <i>If yes, this is a CERCLA Model. Stop</i>			
12.	Is the facility a formerly nuclear, radiological, or high-hazard chemical facility? <i>If Yes, this is an Integrated Sampling Model. Stop.</i>			
13.	Has Environmental Compliance and Area Completion Project's Regulatory Support Group determined that a final survey is not required for this facility? <i>If Yes, this is a Simple Model. If No, this is an Integrated Sampling Model. Stop</i>			

N/A – not applicable

## Part 3. Review of Existing Records

The following facility records were reviewed as a part of this evaluation:

Ref #	Document No.	Revision/Date	Title
1	WSRC-OS-94-42	Rev 0, Aug. 16, 1993 All updates through Sept. 21, 2018, including Rev. 0 Appendices C, G and K for Fiscal Year 2019	FFA for the SRS, Administrative Document No. 89-05-FF
2	N/A	N/A / Since 1993	D-Area SIRIM and ORPS reports 08/1993 to 02/2009.
3	N/A	Final January 26, 2005	Savannah River Site's Cold War Built Environment Cultural Resources Management Plan
4	S-EHS-D-00001	Rev 0/April, 2006	D-Area Hazards Survey
5	Q-APG-D-00007	November 4, 2019	Baseline Asbestos Inspection Report of Building 484-5D