



April 5, 2021

SRNS-J2000-2021-00226
Track Number: 10693

Ms. Susie O'Connor
University of South Carolina – Aiken
Gregg - Graniteville Library
471 University Parkway
Aiken, SC 29801

Mr. Bill Sudduth
Government Information Dept.
Thomas Cooper Library
1322 Greene Street
Columbia, SC 29208

Ms. Melissa Johnson
Reese Library Government Section
Augusta University
2500 Walton Way
Augusta, GA 30909

Ms. LaTasha P. Denard
Asa H. Gordon Library
Savannah State University
2200 Tompkins Rd
Savannah, GA 31404

Industrial Wastewater Closure Module for F-Area Diversion Boxes 5 and 6 F-area Tank Farm, Savannah River Site

Please make the above documents available to the general public for a minimum of 30 days for public comment beginning on April 5, 2021 and ending on May 5, 2021, after which they may be discarded.

Please acknowledge receipt of the document by email to Dexter.McDaniel@srs.gov. If you have any questions, please call me at (803) 952-7401 or e-mail me at above address.

Sincerely,

Dexter McDaniel

Dexter McDaniel
EC & ACP Records
730-4B, Room 135

ADMINISTRATIVE RECORD FILE

Industrial Wastewater Closure Module for F-Area Diversion Boxes 5 and 6 F-Area Tank Farm, Savannah River Site

Please make the above document available to the general public for comment for Thirty days
(30) starting on April 5, 2021 and ending on May 5, 2021

If you have any questions, please contact:

Angela Benfield
Savannah River Nuclear Solutions, LLC
Savannah River Site
Building 730-1B
Aiken, SC 29808
1-803-952-9830
Angela.Benfield@srs.gov

INFORMATION REPOSITORIES

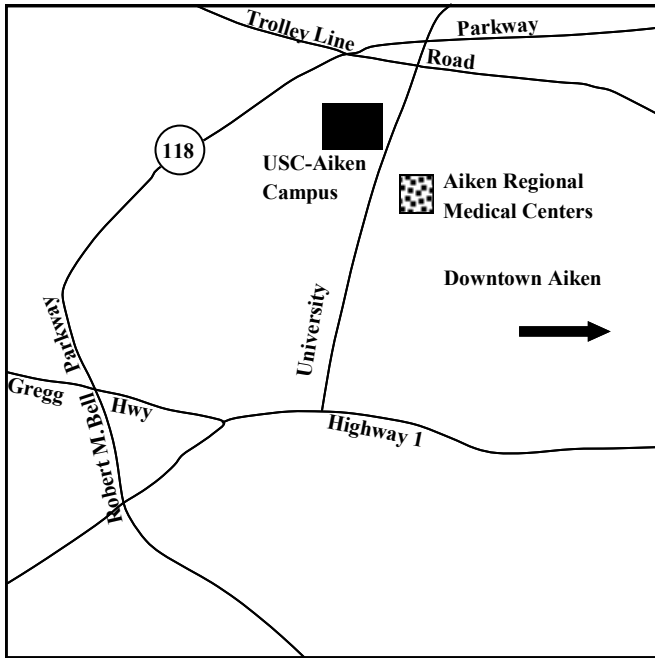

Aiken Information Repository
 U.S. Department of Energy
 Public Reading Room
 USC-Aiken Campus

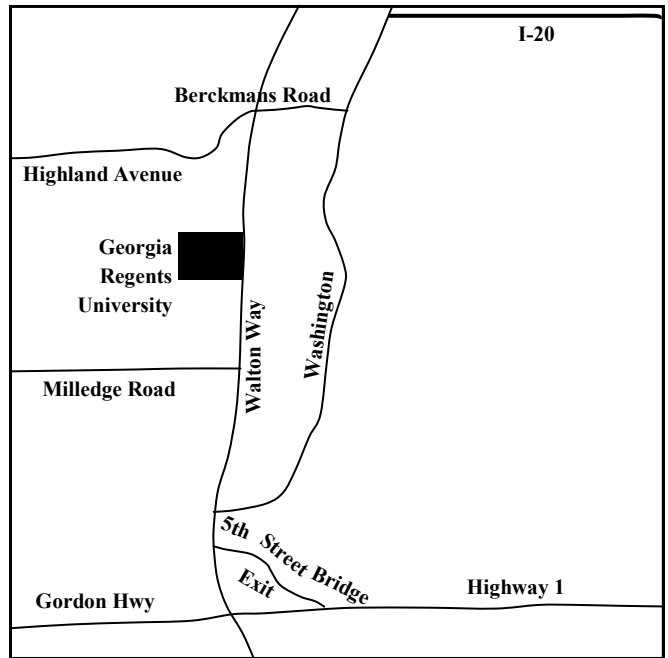

Augusta Information Repository
 Reese Library
 Augusta University

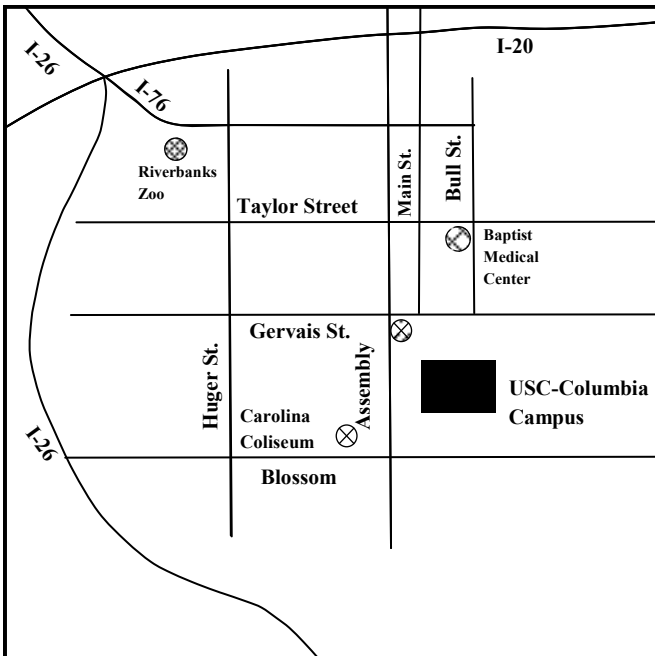

Columbia Information Repository
 Thomas Cooper Library
 University of South Carolina

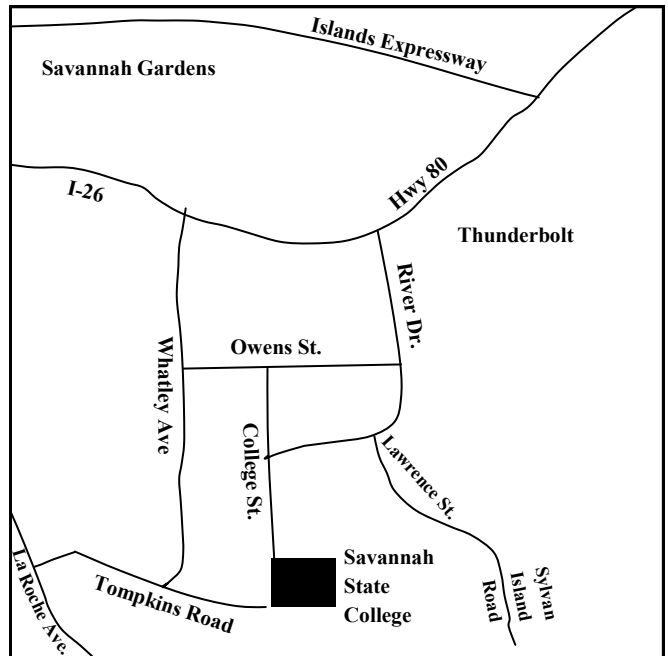

Savannah Information Repository
 Asa H. Gordon Library
 Savannah State College

Definitions:

Each entry in this Administrative Record File contains the following information:

ARF/IRF Catalog Number: A unique number assigned to each document or piece of information. This number appears in the upper right hand corner of the document.

Date: The date the document or information was issued.

Document Number: Many of the documents published or produced by SCDHEC, EPA and SRS are assigned unique numbers. If no document number has been assigned, the Catalog Number is used.

Title: The title of the document, or a brief description of the contents.

Author: The person or party responsible for the issuance or writing of the document or information.

Author Affiliation: The organization that the author works for or is affiliated with.

Addressee: In most cases this entry will be blank except if the document is correspondence. The entry in that case will be the organization(s) to which the Addressee is affiliated.

Appx. No. of Pages: The approximate number of pages the document contains.

Classification: The entry will contain one of the two following codes.

U: The information is unclassified and available to the general public for viewing.

CP: The information or document is considered confidential or privileged. The document may contain sensitive information and is not available to the general public. It may be included in an Administrative Record File as it was used to support the decision making, but cannot be made publicly available.

File Type: One of the following codes will be entered in this area:

ARF: This document is included in the Administrative Record File.or Administrative Record for the unit. The document is physically located either in hard copy or on cd and is available to the general public for viewing and/or copying.

ARF-BRO: This document is included in the Administrative Record File or Administrative Record for the unit. The document will not be on cd because it is classified or privileged information, protected by copy-right laws, or is publicly available technical literature not generated for the unit at issue (i.e.; an engineering textbook).

IRF: This document is provided for information only. It is not used in the decision making process for the unit. It is physically located either in hardcopy or on cd and is available to the general public for viewing and/or copying.

IRF-BRO: This document is listed for information only. It was not used in the decision making process for the unit. It will not be microfilmed because it is protected by copyright laws or is publicly available.

Compact Disk (CD) Number: A typical entry is 101. The document associated with that catalog number is located on that cd in pdf format.

ARF Index 283

Catalog Num	Date	Doc Number	Track #	Title	Author	Addressee	Doc Type	#of Pages
000570	06/17/92 12:00:00 AM	000570	10693	USEPA COMMENTS TO SCDHEC ON THE HIGH LEVEL WASTE TANK ASSESSMENT REPORTS, F- AND H-AREA TANK FARMS	J. D. JOHNSTON	M. F. SADLER	CORRESPONDENCE	23
000610	07/07/92 12:00:00 AM	000610	10693	SCDHEC COMMENTS ON THE PHASE I AND II F- AND H-AREAS HIGH-LEVEL RADIOACTIVE WASTE TANK FARMS ASSESSMENT REPORTS	L. E. ARRINGTON	J. V. ODUM	CORRESPONDENCE	16
000637	05/18/89 12:00:00 AM	000637	10693	SAVANNAH RIVER SITE NOTICE OF DETECTION OF A RELEASE FROM A RESOURCE CONSERVATION AND RECOVERY ACT TANK SYSTEM	S. R. WRIGHT	W. W. CULLER	CORRESPONDENCE	7
000638	06/29/89 12:00:00 AM	000638	10693	CHARACTERIZATION OF SOIL FROM SAVANNAH RIVER SITE (SRS) H-AREA HIGH LEVEL RADIOACTIVE WASTE TANK FARM RELEASE	S. R. WRIGHT	W. W. CULLER	ENVIRONMENTAL REPORT	12
000749	10/26/92 01:00:00 AM	ESH-FSS-920764	10693	SRS RESPONSE TO SCDHEC/EPA REVIEW COMMENTS ON F AND H AREA HIGH LEVEL RADIOACTIVE WASTE TANK FARM ASSESSMENT REPORT (U)	W. D. DUNAWAY	L. E. ARRINGTON	CORRESPONDENCE	1
000902	01/25/93 12:00:00 AM	000902	10693	STATE CONSTRUCTION PERMIT #17, 424-IW, FOR THE F AND H AREA HIGH-LEVEL RADIOACTIVE WASTE TANK FARMS	M. F. SADLER	W,D,DUNAWAY	CORRESPONDENCE	5
001021	06/29/93 12:00:00 AM	ESH-FSS-930430	10693	F AND H AREA HIGH LEVEL RADIOACTIVE WASTE TANK INSPECTION REPORT (U) (REF: WSRC-TR-93-166, REV. 0, CATALOG NO. 001012)	W. D. DUNAWAY	C. W. RICHARDSON	CORRESPONDENCE	1
001234	08/01/91 12:00:00 AM	WSRC-RP-93-549, REV. 0	10693	ASSESSMENT REPORT PHASE II FOR THE F AND H AREA HIGH-LEVEL RADIOACTIVE WASTE TANK FARMS (U)	WSRC		SUPPORTING DOCUMENT	176
001414	03/03/93 12:00:00 AM	17,424-IW	10693	PARTIAL PERMIT TO OPERATE THE F AND H AREA HIGH LEVEL RADIOACTIVE WASTE TANK FARMS CONSTRUCTION PERMIT NO.: 17,424-IW	SCDHEC		SUPPORTING DOCUMENT	4
001436	03/15/94 01:00:00 AM	WSRC-RP-93-271	10693	F/H AREA HIGH LEVEL WASTE TANK STATUS REPORT	DOE-SR		SUPPORTING DOCUMENT	12
001437	11/09/93 12:00:00 AM	001437	10693	WASTE REMOVAL PLAN AND SCHEDULE FOR THE HIGH LEVEL WASTE TANK FARMS(U) (SEE CATALOG NUMBER 001439)	A. B. GOULD	L. R. BEDENBAUGH	ENVIRONMENTAL REPORT	2
001438	11/09/93 12:00:00 AM	001438	10693	WASTE REMOVAL PLAN AND SCHEDULE FOR THE HIGH LEVEL WASTE TANK FARMS(U) (SEE CATALOG NUMBER 001439)	A. B. GOULD	V. L. WEEKS	ENVIRONMENTAL REPORT	2
001439	11/09/93 12:00:00 AM	WSRC-RP-93-147 REV. 0	10693	F/H AREA HIGH LEVEL WASTE REMOVAL PLAN & SCHEDULE	DOE-SR		SUPPORTING DOCUMENT	18
001656	09/16/94 12:00:00 AM	001656	10693	DOE EXTENSION REQUEST FOR F & H-AREA HIGH LEVEL WASTE TANKS SOURCE CONTROL OPERABLE UNITS RECORD OF DECISION	T. M. TREGER	J. L. CRANE/K. A. COLLINSWORT	CORRESPONDENCE	2
001756	10/06/94 12:00:00 AM	001756	10693	SCDHEC ACCEPTANCE OF THE DEFERMENT OF THE F- AND H-AREA HIGH LEVEL WASTE TANKS SOURCE CONTROL OPERABLE UNITS RECORDS OF DECISION	K. A. COLLINSWORTH	T. M. TREGER	CORRESPONDENCE	1

ARF Index 283

Catalog Num	Date	Doc Number	Track #	Title	Author	Addressee	Doc Type	#of Pages
001773	10/19/94 12:00:00 AM	001773	10693	PROPOSAL TO DELETE THE FEDERAL FACILITY AGREEMENT FISCAL YEAR 1994 COMMITMENT FOR F- AND H-AREA HIGH LEVEL WASTE TANKS SOURCE	T. M. TREGER	K. A. COLLINSWORT	CORRESPONDENCE	10
001880	05/01/94 12:00:00 AM	WSRC-TR-94-166	10693	ANNUAL RADIOACTIVE WASTE TANK INSPECTION PROGRAM - 1993(U), (WSRC-TR-94-166) DATED MAY 1994	WSRC		SUPPORTING DOCUMENT	68
002093	03/01/95 12:00:00 AM	WSRC-RP-95-299	10693	F/H AREA HIGH LEVEL WASTE TANK STATUS REPORT (WSRC-RP-95-299) DATED MARCH 1995	WSRC		SUPPORTING DOCUMENT	12
002108	06/07/95 12:00:00 AM	ESH-ERG-95-0231	10693	SUBMITTAL LETTER FOR THE 1994 F/H AREA HIGH LEVEL RADIOACTIVE WASTE TANK INSPECTION REPORT SEE CATALOG NUMBER 002092	W. D. DUNAWAY	J. L. CRANE/K. A. COLLINSWORT	CORRESPONDENCE	1
002738	03/06/96 12:00:00 AM	ESH-CGP-96-0134	10693	TRANSMITTAL OF THE AGENDA AND HANDOUTS FOR THE F-AREA AND H-AREA HIGH LEVEL WASTE TANK CLOSURE MEETING OF MARCH 4, 1996	J. W. COOK	C. FROEDE	CORRESPONDENCE	15
003033	05/22/96 12:00:00 AM	003033	10693	USEPA COMMENTS ON THE DOE INTERNAL DRAFT COPY OF THE INDUSTRIAL WASTEWATER CLOSURE PLAN FOR F-AREA AND H-AREA HIGH LEVEL WASTE TANKS	C. R. FROEDE, JR.	B. T. HENNESSEY	CORRESPONDENCE	4
003037	07/01/96 12:00:00 AM	003037	10693	USEPA COMMENTS ON REVISION. 0 INDUSTRIAL WASTEWATER CLOSURE PLAN F-AREA AND H-AREA HIGH LEVEL WASTE TANK SYSTEMS	C. R. FROEDE, JR.	B. T. HENNESSEY	CORRESPONDENCE	2
003093	05/29/96 12:00:00 AM	ESH-CGP-96-0284	10693	SUBMITTAL LETTER FOR THE 1995 F/H AREA HIGH LEVEL RADIOACTIVE WASTE TANK INSPECTION REPORT (U)	W. D. DUNAWAY	M. F. SADLER	CORRESPONDENCE	1
003189	07/23/96 12:00:00 AM	003189	10693	EPA APPROVAL OF THE REVISION.1 INDUSTRIAL WASTEWATER CLOSURE PLAN F- AND H- AREA HIGH LEVEL WASTE TANK SYSTEMS	C. R. FROEDE, JR.	B. T. HENNESSEY	CORRESPONDENCE	1
003336	09/19/96 12:00:00 AM	ESH-CGP-96-0488	10693	SAMPLING OF POC WELLS FOR APPENDIX IX AND CRML AT F/H AREAS	J. W. COOK	C. L. DEVLIN	CORRESPONDENCE	2
003832	04/21/97 12:00:00 AM	ESH-CGP-97-0111	10693	PROPOSED POINT OF COMPLIANCE (POC) WELLS FOR 1997 APPENDIX AND CRML SAMPLING AT F/H AREAS	J. W. COOK	C. L. DEVLIN	CORRESPONDENCE	2
003929	05/30/97 12:00:00 AM	ESH-CGP-97-0171	10693	SUBMITTAL LETTER FOR THE 1996 F/H AREA HIGH LEVEL RADIOACTIVE WASTE TANK INSPECTION REPORT	J. W. COOK	M. F. SADLER	CORRESPONDENCE	1
004172	08/28/97 12:00:00 AM	004172	10693	SCDHEC COMMENTS ON THE REQUEST FOR APPROVAL OF APPENDIX C OF THE SAVANNAH RIVE SITE F- AND H- AREA HIGH LEVEL WASTE (HLW) TANKS SYSTEMS	K. A. COLLINSWORTH	B. T. HENNESSEY	CORRESPONDENCE	2
004300	10/02/97 12:00:00 AM	004300	10693	SCDHEC APPROVAL OF THE REQUEST FOR DELAY OF SUBMITTING THE REVISED WASTE REMOVAL AND CLOSURE SCHEDULE FOR THE SAVANNAH RIVER SITE F-	K. A. COLLINSWORTH	B. T. HENNESSEY	CORRESPONDENCE	1
004525	03/01/97 12:00:00 AM	WSRC-RP-97-75	10693	F/H AREA HIGH LEVEL WASTE TANK STATUS REPORT	WSRC		ENVIRONMENTAL REPORT	30

ARF Index 283

Catalog Num	Date	Doc Number	Track #	Title	Author	Addressee	Doc Type	#of Pages
004688	03/05/98 12:00:00 AM	OD-98-036	10693	ANNUAL TANK ASSESSMENT REPORT AND STATUS REPORT FOR THE SAVANNAH RIVER SITE (SRS) HIGH LEVEL WASTE (HLW) TANK 1) ANNUAL TANK	B. T. HENNESSEY	J. L. CRANE / K. A. COLLINSWORT	CORRESPONDENCE	2
004690	03/01/98 12:00:00 AM	WSRC-RP-98-88	10693	ENCLOSURE #2 OD-98-036 SEE CATALOG #004688 F/H AREA HIGH LEVEL WASTE TANK STATUS REPORT AS REQUIRED BY THE FEDERAL FACILITY AGREEMENT (FFA)	WSRC		ENVIRONMENTAL REPORT	13
004794	04/17/98 12:00:00 AM	ESH-CGP-98-0117	10693	PROPOSED POC (POINT OF COMPLIANCE) WELLS FOR 1998 APPENDIX IX AND CRML SAMPLING AT F/H AREAS	J. W. COOK	C. L. DEVLIN	CORRESPONDENCE	2
004966	06/09/98 12:00:00 AM	ESH-CGP-98-0188	10693	SUBMITTAL OF THE 1997 F/H AREA HIGH LEVEL RADIOACTIVE WASTE TANK INSPECTION REPORT (WSRC-TR-98-0083)	J.W. COOK	M.F. SADLER	CORRESPONDENCE	1
005945	06/11/96 12:00:00 AM	005945	10693	NEWSPAPER ADVERTISEMENT- A JOINT INFORMATIONAL MEETING WITH EPA SCDHEC, & DOE TO DISCUSS THE CLOSURE PLAN AND ENVIRONMENTAL ASSESSMENT OF	WSRC		COMMUNITY INVOLVEMENT	17
006031	01/19/99 12:00:00 AM	006031	10693	NEWSPAPER ADVERTISEMENT - FUTURE CLOSURES OF HIGH-LEVEL WASTE (HLW) TANKS AT THE SAVANNAH RIVER SITE	WSRC		COMMUNITY INVOLVEMENT	1
✓008849	06/18/20 11	VOLUME 13, No. 11	10693	ENVIRONMENTAL BULLETIN - VOLUME 13, NUMBER 11 - DOE ANNOUNCES AVAILABILITY OF FINAL EIS ON SRS HIGH-LEVEL WASTE TANK CLOSURES, JUNE 18, 2002	WSRC		COMMUNITY INVOLVEMENT	4
✓009559	03/26/20	OD-03-179	10693	DOE LETTER OF THE RECOMMENDATION FOR TWELVE-SITE EVALUATION AREAS LOCATED IN F-AREA TANK FARM. TABLE AND FIGURE ATTACHED	THOMAS JOHNSON, JR.	K. B. FEELY / C. M. GORMAN	CORRESPONDENCE	4
+009599	04/17/20	009599	10693	SCDHEC APPROVAL OF THE TWELVE SITE EVALUATION AREAS IN F-AREA TO BE MOVED TO APPENDIX C AS F-AREA TANK FARM OPERABLE UNIT	C. M. GORMAN	B. T. HENNESSEY	CORRESPONDENCE	1
✓009758	06/16/20	009758	10693	EPA LETTER OF THE MOVING TWELVE SITES WITHIN FFA (RESPONSE TO 03/26/03 LETTER) SITE EVALUATION PROGRAM	DAWN TAYLOR	B. T. HENNESSEY	CORRESPONDENCE	1
+010360	12/01/20	ERD-EN-2003-012	10693	GENERAL SEPARATIONS AREA WESTERN GROUNDWATER OPERABLE UNIT SCOPING SUMMARY (ERD-EN-2003-0121) DATED DECEMBER 2003	WSRC		SUPPORTING DOCUMENT	11
✓010752	04/08/20	010752	10693	SCDHEC LETTER ON THE TANK CLOSURE SCHEDULE FOR THE SAVANNAH RIVER SITE (SRS) HIGH LEVEL WASTE (HLW) TANK SYSTEMS	C. M. GORMAN	B. T. HENNESSEY	CORRESPONDENCE	1
✓010890	04/28/20	010890	10693	SCDHEC DISAPPROVAL OF THE EXTENSION REQUEST DATED APRIL 19, 2004, FOR OPERATIONAL CLOSURE OF TANKS 19F AND 18F SAVANNAH RIVER SITE (SRS) HIGH	C. M. GORMAN	B. T. HENNESSEY	CORRESPONDENCE	1
✓010895	04/29/20	010895	10693	EPA DISAPPROVAL OF THE EXTENSION REQUEST (LETTER DATED APRIL 19, 2004) FOR THE OPERATIONAL CLOSURE OF HIGH-LEVEL WASTE TANKS 19F AND 18F	DAWN C. TAYLOR	B. T. HENNESSEY	CORRESPONDENCE	1
✓010952	05/18/20	DD-04-070	10693	DOE LETTER ON THE SCHEDULE SUPPORTING FEDERAL FACILITY AGREEMENT (FFA) EXTENSION REQUEST FOR THE OPERATIONAL CLOSURE OF SAVANNAH RIVER SITE	B. T. HENNESSEY	C. M. GORMAN, D. C. TAYLOR	CORRESPONDENCE	8

ARF Index 283

Catalog Num	Date	Doc Number	Track #	Title	Author	Addressee	Doc Type	#of Pages
✓010956	04/21/97	010956	10693	SCDHEC LETTER ON THE INDUSTRIAL WASTEWATER CLOSURE MODULE FOR THE HIGH LEVEL WASTE TANK 17 SYSTEM, REV.0, SRS/F AREA, DATED APRIL 21, 1997	MELINDA G. VICKERS	J. W. COOK	CORRESPONDENCE	2
✓011003	06/08/20	011003	10693	SCHEDULE SUPPORTING EXTENSION REQUEST FOR THE OPERATIONAL CLOSURE OF HIGH LEVEL WASTE (HLW) TANKS 19F AND 18F (LETTER DATED MAY 18, 2004)	DAWN C. TAYLOR	B. T. HENNESSEY	CORRESPONDENCE	1
✓011010	06/04/20	011010	10693	SCHEDULE FOR OPERATIONAL CLOSURE OF TANKS 19F AND 18F (DATED MAY 18, 2004) SAVANNAH RIVER SITE (SRS) HIGH LEVEL WASTE (HLW) TANK SYSTEMS	CHARLES M. GORMAN	B. T. HENNESSEY	CORRESPONDENCE	1
✓011050	06/24/20	DD-04-100	10693	DOE LETTER ON THE ACCELERATED SCHEDULE SUPPORTING FEDERAL FACILITY AGREEMENT (FFA) EXTENSION REQUEST FOR THE OPERATIONAL CLOSURE	B. T. HENNESSEY	C. M. GORMAN, D. C. TAYLOR	CORRESPONDENCE	3
✓011183	03/04/97	011183	10693	LETTER TO M. F. SADLER, SCDHEC FROM J. W. COOK, MANAGER, CERCLA, GEOLOGICAL AND PERMITTING SECTION, EPD, (ESH-CGP-97-0066), DATED MARCH, 1997,	J. W. COOK	M. F. SADLER	CORRESPONDENCE	3
✓011184	01/09/97	011184	10693	LETTER TO M. F. SADLER, SCDHEC FROM J. W. COOK, EPD (ESH-CGP-97-0003) ON THE REVISED CLOSURE MODULE FOR THE SAVANNAH RIVER SITE HIGH-LEVEL	J. W. COOK	M. F. SADLER	CORRESPONDENCE	2
✓011201	07/23/20	DD-04-126	10693	DOE SUBMITTAL OF THE ACCELERATED SCHEDULE FOR OPERATIONAL CLOSURE OF SAVANNAH RIVER SITE (SRS) HIGH LEVEL WASTE (HLW) TANK 19F AND 18F	JEFFREY D. ALLISON	C. M. GORMAN, D. C. TAYLOR	CORRESPONDENCE	9
✓011246	08/06/20	011246	10693	SCDHEC CONDITIONALLY APPROVAL OF THE SCHEDULE FOR OPERATIONAL CLOSURE OF TANKS 19F AND 18F (JULY 23, 2004) SAVANNAH RIVER SITE (SRS) HIGH LEVEL	C. M. GORMAN	B. T. HENNESSEY	CORRESPONDENCE	2
✓011259	08/09/20	011259	10693	EPA CONDITIONALLY APPROVAL OF THE ACCELERATED SCHEDULE FOR OPERATIONAL CLOSURE OF HIGH LEVEL WASTE (HLW) TANK 19F AND 18F SYSTEMS (LETTER	DAWN C. TAYLOR	B. T. HENNESSEY	CORRESPONDENCE	1
✓011380	08/26/20	DC-04-0155	10693	DOE LETTER ON THE ACCELERATED SCHEDULE FOR OPERATIONAL CLOSURE OF SAVANNAH RIVER SITE (SRS) HIGH LEVEL WASTE (HLW) TANK 19F AND 18F	JEFFREY M. ALLISON	C. M. GORMAN, D. C. TAYLOR	CORRESPONDENCE	9
✓011602	10/18/20	011602	10693	EPA COMMENTS ON THE INDUSTRIAL WASTEWATER CLOSURE PLAN FOR F- AND H-AREA HIGH LEVEL WASTE TANK SYSTEM, WSRC-2003-00498, AUGUST 16, 2004	DAWN C. TAYLOR	DOUGLAS E. HINTZE	CORRESPONDENCE	5
✓011682	08/01/20	WSRC-TR-2003-01	10693	SUBMITTAL OF PRELIMINARY DRAFT INDUSTRIAL WASTEWATER CLOSURE PLAN FOR F- AND H-AREA HIGH-LEVEL WASTE TANK SYSTEMS,	WSRC		SUPPORTING DOCUMENT	317
✓011728	10/20/20	011728	10693	SCDHEC LETTER FROM BARRY S. MULLINAX TO JEFF NEWMAN, WSRC/EPD ON THE INITIAL COMMENTS ON PRELIMINARY CLOSURE PLAN FOR THE HIGH LEVEL	BARRY S. MULLINAX	JEFF NEWMAN	CORRESPONDENCE	12
✓011729	10/25/20	011729	10693	SCDHEC LETTER FROM BARRY S. MULLINAX TO JEFF NEWMAN ON THE EPA COMMENTS FOR THE PRELIMINARY INDUSTRIAL WASTEWATER CLOSURE	BARRY S. MULLINAX	JEFF NEWMAN	CORRESPONDENCE	5
✓012210	03/09/20	WDPD-05-120	10693	DOE SUBMITTAL LETTER AND REPORT OF THE ANNUAL TANK STATUS REPORT FOR THE SAVANNAH RIVER SITE (SRS) HIGH LEVEL WASTE (HLW) TANK SYSTEMS	B. T. HENNESSEY	C. M. GORMAN, D. C. TAYLOR	CORRESPONDENCE	57

ARF Index 283

Catalog Num	Date	Doc Number	Track #	Title	Author	Addressee	Doc Type	#of Pages
013368	02/02/20	CBU-PIT-2005-002	10693	INDUSTRIAL WASTEWATER CLOSURE MODULE FOR TANK WSRC 19 AND TANK 18 SAVANNAH RIVER SITE,			SUPPORTING DOCUMENT	131
013370	03/23/20	CBU-PIT-2006-000	10693	WSRC TRANSMITTAL OF DRAFT RESPONSES TO COMMENTS ON AUGUST 2004 INDUSTRIAL WASTEWATER CLOSURE PLAN, RSM TRACK #: 10667, DATED MARCH 23,	Steven A. Thomas	Barry Mullinax	CORRESPONDENCE	79
013373	04/18/20	WDPD-06-108	10693	DOE SUBMITTAL ON THE EXTENSION REQUEST FOR COMPLETION OF CLOSURE FOR HIGH LEVEL WASTE (HLW) TANK 19 AND TANK 18 AT SAVANNAH RIVER SITE	B. T. Hennessey	D. C. TAYLOR / C. M. GORMAN	CORRESPONDENCE	1
013383	03/09/20	WDPD-06-100	10693	DOE SUBMITTAL FOR THE F/H AREA HIGH LEVEL WASTE (HLW) TANK STATUS REPORT FOR CALENDAR YEAR (CY) 2005 (ESH-EPG-2006-00005, MARCH 2006) FOR THE	Jeffery M. Allison	D. C. TAYLOR / C. M. GORMAN	CORRESPONDENCE	43
013739	07/06/20	013739	10693	DOE LETTER - BODMAN TO SANFORD - TREATMENT AND DISPOSITION OF THE SALT WASTE IN TANKS LOCATED AT SAVANNAH RIVER SITE, DATED JULY 6, 2006	Samuel W. Bodman	Gov. Mark Sanford	CORRESPONDENCE	2
013751	05/12/20	013751	10693	SCDHEC COMMENTS ON THE INDUSTRIAL WASTEWATER CLOSURE MODULE FOR TANK 19 AND TANK 18, REVISION A, SAVANNAH RIVER SITE, INCLUDING EPA REVIEW,	Shelly Sherritt	Virginia G. Dickert	CORRESPONDENCE	14
014347	03/27/20	014347	10693	SCDHEC COMMENTS ON THE NON-CONCURRENCE OF THE EXTENSION REQUEST FOR COMPLETION OF CLOSURE FOR HIGH LEVEL WASTE TANK 19 AND TANK 18	Charles M. Gorman	B. T. HENNESSEY	CORRESPONDENCE	2
014446	03/09/20	WDPD-07-012	10693	DOE SUBMITTAL OF THE CALENDAR YEAR (CY) 2006 STATUS OF F/H AREA RADIOACTIVE LIQUID WASTE TANKS BEING REMOVED FROM SERVICE	BRIAN HENNESSEY	D.C. TAYLOR/D.L. SIRON	CORRESPONDENCE	2
014447	03/01/20	ESH-EPG-2007-00 REV. 1	10693	CY2006 ANNUAL REPORT, STATUS OF F/H AREA RADIOACTIVE LIQUID WASTE TANKS BEING REMOVED FROM SERVICE, ESH-EPG-2007-00016, REVISION 1,	WSRC		SUPPORTING DOCUMENT	71
014587	03/07/95	GB-95-0081	10693	DOE SUBMITTAL ON THE ANNUAL STATUS REPORT FOR THE SAVANNAH RIVER SITE (SRS) HIGH LEVEL WASTE TANKS, (WSRC-RP-95-299, DATED MARCH 1995)	A. B. GOULD	K. A. COLLINSWORT	CORRESPONDENCE	1
014588	03/07/95	GB-95-0082	10693	DOE SUBMITTAL ON THE ANNUAL STATUS REPORT FOR THE SAVANNAH RIVER SITE (SRS) HIGH LEVEL WASTE TANKS, (WSRC-RP-95-299, DATED MARCH 1995)	A. B. GOULD	J. CRANE	CORRESPONDENCE	1
014739	06/12/20	WSRC-TR-2007-00	10693	SRS CY2006 F/H AREA LIQUID WASTE TANK INSPECTION REPORT (WSRC-TR-2007-00094)	RONALD CAMPBELL	JEFFERY DEBESSONET	SUPPORTING DOCUMENT	107
014740	06/07/20	WSRC-TR-2006-00	10693	SRS CY2005 F/H AREA HIGH LIQUID RADIOACTIVE WASTE TANK INSPECTION REPORT (WSRC-TR-2006-00170), DATED JUNE 7, 2006	RONALD M. CAMPBELL	JEFFREY DEBESSONET	SUPPORTING DOCUMENT	128
014848	09/21/20	014848	10693	SCDHEC COMMENTS ON THE SAVANNAH RIVER SITE FEDERAL FACILITY AGREEMENT DISPUTE RESOLUTION REGARDING THE SCHEDULE FOR COMPLETION OF	DONALD SIRON	BRIAN HENNESSEY	CORRESPONDENCE	2
014946	11/02/20	014946	10693	SCDHEC RESPONSE TO US DEPARTMENT OF ENERGY WRITTEN STATEMENT OF DISPUTE FOR USE BY THE DISPUTE RESOLUTION COMMITTEE (DRC) AND UPDATED	DONALD SIRON	B. T. HENNESSEY	CORRESPONDENCE	2

ARF Index 283

Catalog Num	Date	Doc Number	Track #	Title	Author	Addressee	Doc Type	#of Pages
014990	11/29/20	ACP-08-119	10693	DOE SUBMITTAL OF THE SIGNED STATEMENT OF RESOLUTION OF DISPUTE CONCERNING EXTENSION OF CLOSURE DATES FOR SAVANNAH RIVER SITE	BRIAN HENNESSEY	R.H. POPE/D.L. SIRON	CORRESPONDENCE	5
014993	10/22/20	WDPD-08-009	10693	DOE SUBMITTAL OF THE WRITTEN STATEMENT OF DISPUTE SUBMITTED TO THE DISPUTE RESOLUTION COMMITTEE (DRC), (REFERENCE 1, SECTION XXVII.A AND	TERRY J. SPEARS	F. HILL/D.W. CHIEF	CORRESPONDENCE	5
015025	12/20/20	ACP-08-131	10693	DOE SUBMITTAL OF THE FEDERAL FACILITY AGREEMENT (FFA) MODIFICATION TO INCORPORATE STATEMENT OF RESOLUTION OF DISPUTE CONCERNING EXTENSION OF	BRIAN HENNESSEY	R.L. POPE/D.L. SIRON	CORRESPONDENCE	8
✓015574	08/25/20	015574	10693	SCDHEC CORRESPONDENCE ON THE F-AREA AND H-AREA HIGH LEVEL WASTE TANK CLOSURE PLAN AND PERFORMANCE ASSESSMENT SAVANNAH RIVER SITE.	MELISSA J. KING	GENE H. LASKA	CORRESPONDENCE	1
✓015575	08/16/20	015575	10693	WSRC CORRESPONDENCE ON THE SAVANNAH RIVER SITE F-AREA AND H-AREA HIGH LEVEL WASTE TANK CLOSURE PLAN AND PERFORMANCE ASSESSMENT -	GENE H. LASKA	ADRIENNE F. WRIGHT	CORRESPONDENCE	13
✓015722	10/31/20	WDPD-09-005	10693	DOE SUBMITTAL OF THE STATUS OF WASTE REMOVAL ACTIVITIES IN TANKS 18 AND 19	BRIAN HENNESSEY	R.H. POPE/V. KEISLER	CORRESPONDENCE	2
✓015758	11/05/20	015758	10693	SCDHEC COMMENTS ON THE LETTER - HENNESSEY TO KEISLER AND POPE, STATUS OF WASTE REMOVAL ACTIVITIES IN TANK 18 AND 19, DATED OCTOBER 31, 2008	VAN KEISLER	B. T. HENNESSEY	CORRESPONDENCE	2
✓015795	12/23/20	015795	10693	EPA APPROVAL OF THE SAVANNAH RIVER SITE (SRS) EXTENSION REQUEST FOR WASTE REMOVAL ACTIVITIES IN TANK 18 AND 19, DATED DECEMBER 22, 2008	ROBERT POPE	B. T. HENNESSEY	CORRESPONDENCE	2
✓015801	12/22/20	WDPD-09-008	10693	DOE SUBMITTAL OF THE WASTE REMOVAL ACTIVITIES IN TANKS 19 AND 18. REF. (1) LETTER, KEISLER TO HENNESSEY, 11/5/08, (2) LETTER, HENNESSEY TO SIRON	BRIAN HENNESSEY	R.H. POPE/V. KEISLER	CORRESPONDENCE	2
✓015816	01/07/20	015816	10693	SCDHEC APPROVAL OF THE WASTE REMOVAL ACTIVITIES IN TANK 18 AND 19, DATED DECEMBER 22, 2008, REFERENCED IN A SCDHEC LETTER FROM	VAN KEISLER	B. T. HENNESSEY	CORRESPONDENCE	2
✓015818	01/05/20	015818	10693	EPA COMMENTS ON THE PERFORMANCE ASSESSMENT FOR THE F-TANK FARM AT THE SAVANNAH RIVER SITE, REVISION 0, DATED JUNE 27, 2008 (SRS-REG-2007-00002)	MARTHA BERRY	B. T. HENNESSEY	CORRESPONDENCE	17
✓015857	08/20/20	WDPD-08-070	10693	DOE SUBMITTAL OF THE PERFORMANCE ASSESSMENT FOR THE F-TANK FARM AT THE SAVANNAH RIVER SITE, REVISION 0, DATED JUNE 27, 2008	TERRELL J. SPEARS	PATTY DUNBAR	CORRESPONDENCE	2
✓015858	08/20/20	WDPD-08-071	10693	DOE SUBMITTAL OF THE PERFORMANCE ASSESSMENT FOR THE F-TANK FARM AT THE SAVANNAH RIVER SITE, REVISION 0, DATED JUNE 27, 2008	BRIAN HENNESSEY	R.H. POPE/V. KEISLER	CORRESPONDENCE	2
✓015859	06/26/20	SRS-REG-2008-0C	10693	SUBMITTAL OF THE PERFORMANCE ASSESSMENT FOR THE F-TANK FARM AT THE SAVANNA RIVER SITE (THIS IS IN REFERENCE TO: SRS-REG-2007-00002, REVISION 0,	V.G. Dickert	L. D. Olson	CORRESPONDENCE	5
✓015860	08/13/20	SRS-REG-2007-0C REV. 0	10693	PART I: REVIEW TEAM REPORT FOR THE PERFORMANCE ASSESSMENT FOR THE F-TANK FARM AT THE SAVANNAH RIVER SITE, DATED AUGUST 13, 2008 AND	WSRC		SUPPORTING DOCUMENT	2720

ARF Index 283

Catalog Num	Date	Doc Number	Track #	Title	Author	Addressee	Doc Type	#of Pages
015861	06/27/20	SRS-REG-2007-00	10693	PART II: PERFORMANCE ASSESSMENT FOR THE F-TANK FARM AT THE SAVANNAH RIVER SITE (REDACTED VERSION) SRS-REG-2007-00002 REVISION 0 DATED JUNE	WSRC		SUPPORTING DOCUMENT	6,354
015862	06/27/20	SRS-REG-2007-00	10693	PART III: PERFORMANCE ASSESSMENT FOR THE F-TANK FARM AT THE SAVANNAH RIVER SITE (REDACTED VERSION) SRS-REG-2007-00002, REVISION 0, DATED JUNE	WSRC		SUPPORTING DOCUMENT	6,308
015863	06/27/20	SRS-REG-2007-00	10693	PART IV: PERFORMANCE ASSESSMENT FOR THE F-TANK FARM AT THE SAVANNAH RIVER SITE (REDACTED VERSION) SRS-REG-2007-00002, REVISION 0, DATED JUNE	WSRC		SUPPORTING DOCUMENT	6,199
015864	06/27/20	SRS-REG-2007-00	10693	PART V: PERFORMANCE ASSESSMENT FOR THE F-TANK FARM AT THE SAVANNAH RIVER SITE (REDACTED VERSION) SRS-REG-2007-00002, REVISION 0, DATED JUNE	WSRC		CORRESPONDENCE	6,289
015865	06/27/20	SRS-REG-2007-00	10693	PART VI: PERFORMANCE ASSESSMENT FOR THE F-TANK FARM AT THE SAVANNAH RIVER SITE (REDACTED VERSION) SRS-REG-2007-00002, REVISION 0, DATED JUNE	WSRC		SUPPORTING DOCUMENT	2,611
015869	10/31/20	015869	10693	SCDHEC COMMENTS ON THE PERFORMANCE ASSESSMENT FOR THE F-TANK FARM AT THE SAVANNAH RIVER SITE, REVISION 0, (DOCUMENT NO.	VAN KEISLER	B. T. HENNESSEY	CORRESPONDENCE	11
015911	02/19/20	LWO-CES-2009-00	10693	SRS TRANSMITTAL OF CY2008 ANNUAL REPORT STATUS OF F/H AREA RADIOACTIVE LIQUID WASTE TANKS BEING REMOVED FROM SERVICE, MARCH 2009	DANIEL P. SKIFF	MICHAEL HUGHES	CORRESPONDENCE	1
015912	02/25/20	SRNS-J2000-2009	10693	SRNS TRANSMITTAL OF THE CY2008 ANNUAL REPORT STATUS OF F/H AREA RADIOACTIVE LIQUID WASTE TANKS BEING REMOVED FROM SERVICE, MARCH 2009	JEANNETTE E. HYATT	SHERRI R. ROSS	CORRESPONDENCE	2
015913	03/02/20	WDPD-09-022	10693	DOE SUBMITTAL OF THE CALENDAR YEAR (CY) 2008 ANNUAL REPORT STATUS OF F/H AREA RADIOACTIVE LIQUID WASTE TANKS BEING REMOVED FROM SERVICE	BRIAN HENNESSEY	R.H. POPE/V. KEISLER	CORRESPONDENCE	2
015914	03/01/20	LWO-CES-2009-00	10693	CY2008 ANNUAL REPORT STATUS OF F/H AREA RADIOACTIVE LIQUID WASTE TANKS BEING REMOVED FROM SERVICE (LWO-CES-2009-00001, MARCH 2009)	WSRC		SUPPORTING DOCUMENT	74
016088	05/21/20	016088	10693	EPA COMMENTS ON THE CY2008 ANNUAL REPORT STATUS OF F/H AREA RADIOACTIVE LIQUID WASTE TANKS BEING REMOVED FROM SERVICE,	MARTHA BERRY	B. T. HENNESSEY	CORRESPONDENCE	4
016235	02/26/20	LWO-LWE-2008-00	10693	TANKS 18 AND 19 WASTE DETERMINATION SAMPLE PLAN, LWO-LWE-2008-00186, REVISION 1, DATED FEBRUARY 2009	T. HUFF/G.D. THAXTON	J.R. CANTRELL/J.E. HERBERT	SUPPORTING DOCUMENT	13
016236	07/24/20	016236	10693	SCDHEC COMMENTS ON TANKS 18 AND 19 WASTE DETERMINATION SAMPLE PLAN, LWO-LWE-2008-00186, REVISION 1, DATED FEBRUARY 26, 2009	VAN KEISLER	B. T. HENNESSEY	CORRESPONDENCE	2
016237	07/09/20	016237	10693	EPA COMMENTS ON TANKS 18 AND 19 WASTE DETERMINATION SAMPLE PLAN, LWO-LWE-2008-00186, REVISION 1, DATED FEBRUARY 26, 2009	MARTHA BERRY	VAN KEISLER	CORRESPONDENCE	6
016290	08/24/20	WDPD-09-055	10693	DOE SUBMITTAL OF THE RESPONSES TO THE EPA REVIEW OF THE CALENDAR YEAR (CY) 2008 ANNUAL REPORT STATUS OF F/H AREA RADIOACTIVE LIQUID	BRIAN HENNESSEY	R.H. POPE/V. KEISLER	CORRESPONDENCE	10

ARF Index 283

Catalog Num	Date	Doc Number	Track #	Title	Author	Addressee	Doc Type	#of Pages
016390	10/23/20	WDPD-10-02	10693	DOE SUBMITTAL OF THE REQUEST FOR CONCURRENCE TO PROCEED TO SAMPLE AND ANALYSIS PHASE OF THE TANK CLOSURE PROCESS FOR TANKS 18 AND 19	BRIAN HENNESSEY	R.H. POPE/V. KEISLER	CORRESPONDENCE	2
016391	10/01/20	SRR-CWDA-2009-	10693	PROPOSAL TO CEASE WASTE REMOVAL ACTIVITIES IN TANKS 18 AND 19 AND ENTER SAMPLING AND ANALYSIS PHASE, SRR-CWDA-2009-00030, DATED OCTOBER 1, 2009	SRNS		SUPPORTING DOCUMENT	58
016413	11/06/20	016413	10693	EPA APPROVAL OF DOE SUBMITTAL OF THE REQUEST FOR CONCURRENCE TO PROCEED TO SAMPLE AND ANALYSIS PHASE OF THE TANK CLOSURE PROCESS FOR	MARTHA MERRY	B. T. HENNESSEY	CORRESPONDENCE	2
016414	11/09/20	016414	10693	SCDHEC APPROVAL OF THE REQUEST FOR CONCURRENCE TO PROCEED TO SAMPLE AND ANALYSIS PHASE OF THE TANK CLOSURE PROCESS FOR TANKS 18	VAN KEISLER	B. T. HENNESSEY	CORRESPONDENCE	1
016703	03/08/20	WDPD-10-042	10693	DOE SUBMITTAL OF THE CALENDAR YEAR (CY) 2009 ANNUAL REPORT STATUS OF F/H AREA RADIOACTIVE LIQUID WASTE TANKS BEING REMOVED FROM SERVICE,	BRIAN HENNESSEY	R.H. POPE/V. KEISLER	CORRESPONDENCE	2
016704	03/01/20	LWO-CES-2010-0	10693	CY2009 ANNUAL REPORT STATUS OF F/H AREA RADIOACTIVE LIQUID WASTE TANKS BEING REMOVED FROM SERVICE (LWO-CES-2010-00001, MARCH 2010)	SRNS		SUPPORTING DOCUMENT	89
016711	02/23/20	SRR-LWE-2010-0	10693	SRR RESPONSES TO SCDHEC AND EPA COMMENTS ON THE TANKS 18 AND 19 WASTE DETERMINATION SAMPLE PLAN, LWO-LWE-2008-00186, REVISION 1, FEBRUARY 26,	WALT ISOM	SHERRI R. ROSS	CORRESPONDENCE	
016794	04/15/20	016794	10693	SCDHEC COMMENTS ON THE CY2009 ANNUAL REPORT STATUS OF F/H AREA RADIOACTIVE LIQUID WASTE TANKS BEING REMOVED FROM SERVICE (AS REQUIRED	VAN KEISLER	B. T. HENNESSEY	CORRESPONDENCE	4
017057	08/09/20	WDPD-10-074	10693	DOE SUBMITTAL OF THE COMPLETION OF BULK WASTE REMOVAL (BWR) EFFORT IN TANK 8	BRIAN HENNESSEY	R.H. POPE/V. KEISLER	CORRESPONDENCE	20
017065	08/30/20	017065	10693	SCDHEC SUBMITTAL OF THE FEDERAL FACILITY AGREEMENT (FFA) MODIFICATION TO INCORPORATE THE ADDENDUM TO THE STATEMENT OF RESOLUTION OF	VAN KEISLER	MARTHA BERRY	CORRESPONDENCE	4
017078	08/25/20	ACP-10-253	10693	DOE SUBMITTAL OF THE FEDERAL FACILITY AGREEMENT (FFA) MODIFICATION TO INCORPORATE THE ADDENDUM TO THE STATEMENT OF RESOLUTION OF DISPUTE	BRIAN HENNESSEY	R.H. POPE/V. KEISLER	CORRESPONDENCE	4
017094	06/25/20	LWO-CES-2010-0	10693	SRR SUBMITTAL OF THE SAVANNAH RIVER SITE ANNUAL RADIOACTIVE WASTE TANK INSPECTION PROGRAM - 2009 (SRR-STI-2010-00283)	PATRICIA M. ALLEN	R.H. POPE/J.P. DEBESSONET	CORRESPONDENCE	3
017095	06/01/20	SRR-STI-2010-002	10693	ANNUAL RADIOACTIVE WASTE TANK INSPECTION PROGRAM - 2009, SRR-STI-2010-000283, DATED JUNE 2010	SRR		SUPPORTING DOCUMENT	112
017103	08/31/20	017103	10693	EPA COMMENTS ON THE SRS ANNUAL RADIOACTIVE WASTE TANK INSPECTION PROGRAM - 2009, SRR-STI-2010-000283, DATED JUNE 2010	MARTHA BERRY	B. T. HENNESSEY	CORRESPONDENCE	3
017110	08/30/20	017110	10693	EPA SUBMITTAL OF THE FEDERAL FACILITY AGREEMENT (FFA) MODIFICATION TO INCORPORATE THE ADDENDUM TO THE STATEMENT OF RESOLUTION OF DISPUTE	MARTHA BERRY	B. T. HENNESSEY	CORRESPONDENCE	7

ARF Index 283

Catalog Num	Date	Doc Number	Track #	Title	Author	Addressee	Doc Type	#of Pages
✓017113	04/07/20	WDPD-10-050	10693	DOE SUBMITTAL OF THE PERFORMANCE ASSESSMENT FOR THE F-TANK FARM AT THE SAVANNAH RIVER SITE (SRS), (SRS-REG-2007-00002, REVISION 1, DATED MARCH	BRIAN HENNESSEY	R.H. POPE/V. KEISLER	CORRESPONDENCE	3
✓017114	03/31/20	SRS-REG-2007-0C REV. 1	10693	PART I - APPROVED FOR PUBLIC RELEASE - PERFORMANCE ASSESSMENT FOR THE F-TANK FARM AT THE SAVANNAH RIVER SITE, SRS-REG-2007-00002,	SRR		SUPPORTING DOCUMENT	5056
✓017115	03/31/20	SRS-REG-2007-0C REV. 1	10693	PART II - APPROVED FOR PUBLIC RELEASE - REFERENCES FOR THE PERFORMANCE ASSESSMENT FOR THE F-TANK FARM AT THE SAVANNAH RIVER SITE,	SRR		SUPPORTING DOCUMENT	5145
✓017116	03/31/20	SRS-REG-2007-0C REV. 1	10693	PART III - APPROVED FOR PUBLIC RELEASE - REFERENCES FOR THE PERFORMANCE ASSESSMENT FOR THE F-TANK FARM AT THE SAVANNAH RIVER SITE,	SRR		SUPPORTING DOCUMENT	6322
✓017117	03/31/20	SRS-REG-2007-0C REV. 1	10693	PART IV - APPROVED FOR PUBLIC RELEASE - REFERENCES FOR THE PERFORMANCE ASSESSMENT FOR THE F-TANK FARM AT THE SAVANNAH RIVER SITE,	SRR		SUPPORTING DOCUMENT	5217
✓017118	09/07/20	017118	10693	SCDHEC APPROVAL TO CONTINUE USING TANK 8	VAN KEISLER	B. T. HENNESSEY	CORRESPONDENCE	2
✓017119	03/31/20	SRS-REG-2007-0C REV. 1	10693	PART V - APPROVED FOR PUBLIC RELEASE - REFERENCES FOR THE PERFORMANCE ASSESSMENT FOR THE F-TANK FARM AT THE SAVANNAH RIVER SITE,	SRR		SUPPORTING DOCUMENT	5962
✓017120	09/21/20	017120	10693	EPA APPROVAL OF THE COMPLETION OF BULK WASTE REMOVAL (BWR) EFFORTS IN TANK 8	ROBERT POPE	B. T. HENNESSEY	CORRESPONDENCE	2
+017121	03/31/20	SRS-REG-2007-0C REV. 1	10693	PART VI - APPROVED FOR PUBLIC RELEASE - REFERENCES FOR THE PERFORMANCE ASSESSMENT FOR THE F-TANK FARM AT THE SAVANNAH RIVER SITE,	SRR		SUPPORTING DOCUMENT	975
✓017122	06/29/20	017122	10693	SCDHEC COMMENTS ON THE PERFORMANCE ASSESSMENT FOR THE F-TANK FARM AT THE SAVANNAH RIVER SITE (SRS), (SRS-REG-2007-00002, REVISION 1,	VAN KEISLER	B. T. HENNESSEY	CORRESPONDENCE	4
✓017123	06/30/20	017123	10693	EPA COMMENTS ON THE PERFORMANCE ASSESSMENT FOR THE F-TANK FARM AT THE SAVANNAH RIVER SITE, (SRS-REG-2007-00002, REVISION 1, DATED MARCH 31,	MARTHA BERRY	B. T. HENNESSEY	CORRESPONDENCE	7
✓017126	09/17/20	WDPD-10-081	10693	DOE SUBMITTAL OF THE COMPLETION OF BULK WASTE REMOVAL (BWR) EFFORTS IN TANK 12,	BRIAN HENNESSEY	R.H. POPE/V. KEISLER	CORRESPONDENCE	2
✓017127	09/08/20	SRR-CWDA-2010- REV. 1	10693	COMPLETION OF BULK WASTE REMOVAL (BWR) EFFORTS IN TANK 12, SRR-CWDA-2010-00126, REVISION 1, DATED SEPTEMBER 8, 2010	SRR		SUPPORTING DOCUMENT	18
✓017129	09/23/20	ACP-10-269	10693	DOE SUBMITTAL OF THE THREE-PARTY SIGNED FEDERAL FACILITY AGREEMENT MODIFICATION TO INCORPORATE THE ADDENDUM TO THE STATEMENT OF RESOLUTION OF	BRIAN HENNESSEY	R.H. POPE/V. KEISLER	CORRESPONDENCE	4
✓017167	09/29/20	017167	10693	SCDHEC APPROVAL OF THE COMPLETION OF BULK WASTE REMOVAL (BWR) EFFORTS IN TANK 12, SRR-CWDA-2010-00126, REVISION 1, DATED SEPTEMBER	VAN KEISLER	B. T. HENNESSEY	CORRESPONDENCE	1

ARF Index 283

Catalog Num	Date	Doc Number	Track #	Title	Author	Addressee	Doc Type	#of Pages
017196	09/29/20	017196	10693	EPA CONCURRENCE OF COMPLETION OF BULK WASTE REMOVAL (BWR) EFFORTS IN TANK 12	R. H. POPE	B. T. HENNESSEY	CORRESPONDENCE	2
017234	11/10/20	WDPD-11-12	10693	DOE REQUEST FOR CONCURRENCE TO PROCEED TO SAMPLE AND ANALYSIS PHASE OF THE TANK CLOSURE PROCESS FOR TANKS 5 AND 6. (SRR-CWDA-2010-00157,	BRIAN HENNESSEY	R.H. POPE/V. KEISLER	CORRESPONDENCE	188
017266	11/22/20	017266	10693	SCDHEC APPROVAL OF THE CONCURRENCE TO PROCEED TO SAMPLE AND ANALYSIS PHASE OF THE TANK CLOSURE PROCESS FOR TANKS 5 AND 6, DATED	VAN KEISLER	B. T. HENNESSEY	CORRESPONDENCE	1
017273	03/31/20	SRS-REG-2007-0C REV. 1	10693	PART I: OJO VERSION OF THE - PERFORMANCE ASSESSMENT FOR THE F-TANK FARM AT THE SAVANNAH RIVER SITE (REDACTED VERSION) SRS-REG-2007-00002,	SRNS		SUPPORTING DOCUMENT	3125
017274	03/31/20	SRS-REG-2007-0C REV.1	10693	PART II - OJO REFERENCES FOR THE PERFORMANCE ASSESSMENT FOR THE F-TANK FARM AT THE SAVANNAH RIVER SITE (REDACTED VERSION) SRS-REG-2007-00002,	SRNS		SUPPORTING DOCUMENT	755
017275	03/31/20	SRS-REG-2007-0C REV. 1	10693	PART III - OJO REFERENCES FOR THE PERFORMANCE ASSESSMENT FOR THE F-TANK FARM AT THE SAVANNAH RIVER SITE (REDACTED VERSION) SRS-REG-2007-00002,	SRNS		SUPPORTING DOCUMENT	1659
017276	03/31/20	SRS-REG-2007-0C REV. 1	10693	PART IV - OJO REFERENCES FOR THE PERFORMANCE ASSESSMENT FOR THE F-TANK FARM AT THE SAVANNAH RIVER SITE (REDACTED VERSION) SRS-REG-2007-00002,	SRNS		SUPPORTING DOCUMENT	1469
017277	03/31/20	SRS-REG-2007-0C REV. 1	10693	PART V - OJO REFERENCES FOR THE PERFORMANCE ASSESSMENT FOR THE F-TANK FARM AT THE SAVANNAH RIVER SITE (REDACTED VERSION) SRS-REG-2007-00002,	SRNS		SUPPORTING DOCUMENT	2219
017278	03/31/20	SRS-REG-2007-0C REV. 1	10693	PART VI - OJO REFERENCES FOR THE PERFORMANCE ASSESSMENT FOR THE F-TANK FARM AT THE SAVANNAH RIVER SITE (REDACTED VERSION) SRS-REG-2007-00002,	SRNS		SUPPORTING DOCUMENT	1513
017279	03/31/20	SRS-REG-2007-0C REV. 1	10693	PART VII - OJO REFERENCES FOR THE PERFORMANCE ASSESSMENT FOR THE F-TANK FARM AT THE SAVANNAH RIVER SITE (REDACTED VERSION) SRS-REG-2007-00002,	SRNS		SUPPORTING DOCUMENT	1447
017280	03/31/20	SRS-REG-2007-0C REV. 1	10693	PART VIII - OJO REFERENCES FOR THE PERFORMANCE ASSESSMENT FOR THE F-TANK FARM AT THE SAVANNAH RIVER SITE (REDACTED VERSION) SRS-REG-2007-00002,	SRNS		SUPPORTING DOCUMENT	2326
017281	03/31/20	SRS-REG02007-0I REV. 1	10693	PART IX - OJO REFERENCES FOR THE PERFORMANCE ASSESSMENT FOR THE F-TANK FARM AT THE SAVANNAH RIVER SITE (REDACTED VERSION) SRS-REG-2007-00002,	SRNS		SUPPORTING DOCUMENT	1577
017282	03/31/20	SRS-REG-2007-0C REV. 1	10693	PART X - OJO REFERENCES FOR THE PERFORMANCE ASSESSMENT FOR THE F-TANK FARM AT THE SAVANNAH RIVER SITE (REDACTED VERSION) SRS-REG-2007-00002,	SRNS		SUPPORTING DOCUMENT	1803
017283	03/31/20	SRS-REG-2007-0C REV. 1	10693	PART XI - OJO REFERENCES FOR THE PERFORMANCE ASSESSMENT FOR THE F-TANK FARM AT THE SAVANNAH RIVER SITE (REDACTED VERSION) SRS-REG-2007-00002,	SRNS		SUPPORTING DOCUMENT	1541
017285	03/31/20	SRS-REG-2007-0C REV. 1	10693	PART XII - OJO REFERENCES FOR THE PERFORMANCE ASSESSMENT FOR THE F-TANK FARM AT THE SAVANNAH RIVER SITE (REDACTED VERSION) SRS-REG-2007-00002,	SRNS		CORRESPONDENCE	2038

ARF Index 283

Catalog Num	Date	Doc Number	Track #	Title	Author	Addressee	Doc Type	#of Pages
✓017286	03/31/20	SRS-REG-2007-0C REV. 1	10693	PART XIII - OOU REFERENCES FOR THE PERFORMANCE ASSESSMENT FOR THE F-TANK FARM AT THE SAVANNAH RIVER SITE (REDACTED VERSION) SRS-REG-2007-00002,	SRNS		SUPPORTING DOCUMENT	2246
✓017287	03/31/20	SRS-REG-2007-0C REV. 1	10693	PART XIV - OOU REFERENCES FOR THE PERFORMANCE ASSESSMENT FOR THE F-TANK FARM AT THE SAVANNAH RIVER SITE (REDACTED VERSION) SRS-REG-2007-00002,	SRNS		SUPPORTING DOCUMENT	1555
✓017288	03/31/20	SRS-REG-2007-0C REV. 1	10693	PART XV - OOU REFERENCES FOR THE PERFORMANCE ASSESSMENT FOR THE F-TANK FARM AT THE SAVANNAH RIVER SITE (REDACTED VERSION) SRS-REG-2007-00002,	SRNS		SUPPORTING DOCUMENT	1576
✓017289	03/31/20	SRS-REG-2007-0C REV. 1	10693	PART XVI - OOU REFERENCES FOR THE PERFORMANCE ASSESSMENT FOR THE F-TANK FARM AT THE SAVANNAH RIVER SITE (REDACTED VERSION) SRS-REG-2007-00002,	SRNS		SUPPORTING DOCUMENT	1652
✓017306	03/31/20	SRS-REG-2007-0C REV. 1	10693	PART XVII - SUPPORTING DOCUMENT NRC-SRR-CWDA-2009-00054, REVISION 0, COMMENT	SRNS		SUPPORTING DOCUMENT	1043
✓017307	03/31/20	SRS-REG-2007-0C REV. 1	10693	RESPONSE MATRIX FOR NUCLEAR REGULATORY PART XVIII - SUPPORTING DOCUMENT EPA-SRR-CWDA-2009-00055, REVISION 0, COMMENT	SRNS		SUPPORTING DOCUMENT	675
✓017308	03/31/20	SRS-REG-2007-0C REV.1	10693	RESPONSE MATRIX FOR ENVIRONMENTAL PROTECTION PART XIX - SUPPORTING DOCUMENT DHEC-SRR-CWDA-2009-00059, REVISION 0, COMMENT	SRNS		SUPPORTING DOCUMENT	989
✓017329	12/08/20	017329	10693	RESPONSE MATRIX FOR S.C. DEPARTMENT OF HEALTH & EPA COMMENTS ON THE DOE REQUEST FOR CONCURRENCE TO PROCEED TO SAMPLE AND ANALYSIS	ROBERT POPE	B. T. HENNESSEY	CORRESPONDENCE	2
017466	03/07/20	WDPD-11-45	10693	PHASE OF THE TANK CLOSURE PROCESS FOR TANKS 5 DOE SUBMITTAL OF THE CALENDAR YEAR (CY) 2010	BRIAN HENNESSEY	R.H. POPE/V. KEISLER	CORRESPONDENCE	2
017467	03/01/20	SRR-CES-2011-0C	10693	ANNUAL REPORT STATUS OF F/H AREA RADIOACTIVE LIQUID WASTE TANKS BEING REMOVED FROM SERVICE	SRR		SUPPORTING DOCUMENT	96
✚017540	04/07/20	ACP-11-186	10693	CALENDAR YEAR (CY) 2010 ANNUAL REPORT STATUS OF REMOVED FROM SERVICE SRR-CES-2011-00002, DATED DOE SUBMITTAL OF THE OPTION PAPER FOR SAVANNAH	BRIAN HENNESSEY	R.H. POPE/V. KEISLER	CORRESPONDENCE	6
✚017601	04/19/20	017601	10693	RIVER SITE (SRS) LIQUID WASTE SYSTEM, NON-ENFORCEABLE SUBMITTAL DATES SCDHEC COMMENTS ON THE CALENDAR YEAR (CY) 2010	VAN KEISLER	B. T. HENNESSEY	CORRESPONDENCE	2
✚017695	05/09/20	WDPD-11-47	10693	ANNUAL REPORT STATUS OF F/H AREA RADIOACTIVE LIQUID WASTE TANKS BEING REMOVED FROM SERVICE DOE SUBMITTAL OF THE COMPLETION OF BULK WASTE	BRIAN HENNESSEY	R.H. POPE/V. KEILSLER	CORRESPONDENCE	22
✚017707	05/11/20	017707	10693	REMOVAL BWR EFFORTS IN TANK 11				
✚017707	05/11/20	017707	10693	SCDHEC COMMENTS ON THE OPTION PAPER FOR SAVANNAH RIVER SITE SRS LIQUID WASTE SYSTEM NON-ENFORCEABLE FFA MILESTONES	VAN KEISLER	B. T. HENNESSEY		1
✚017712	05/11/20	017712	10693	EPA COMMENT ON THE SUBMITTAL OF THE OPTION PAPER FOR SAVANNAH RIVER SITE SRS LIQUID WASTE SYSTEM NON-ENFORCEABLE SUBMITTAL APRIL 7, 2011	ROBERT POPE	B. T. HENNESSEY	CORRESPONDENCE	2

ARF Index 283

Catalog Num	Date	Doc Number	Track #	Title	Author	Addressee	Doc Type	#of Pages
+017717	05/18/20	017717	10693	EPA APPROVAL OF THE COMPLETION OF BULK WASTE REMOVAL BWR EFFORTS IN TANK 11 AND CONTINUED USE OF TANK 11	ROBERT POPE	B. T. HENNESSEY	CORRESPONDENCE	2
+017723	05/25/20	017723	10693	SCDHEC APPROVAL OF THE COMPLETION OF BULK WASTE REMOVAL BWR EFFORTS IN TANK 11 MAY 9, 2011 REFERENCED IN LETTER FROM HENNESSEY TO KEISLER	VAN KEISLER	B. T. HENNESSEY	CORRESPONDENCE	1
+017728	06/01/20	WDPD-11-67	10693	DOE SUBMITTAL OF THE COMPLETION OF BULK WASTE REMOVAL BWR EFFORTS IN TANK 4	BRIAN HENNESSEY	R.H. POPE/V. KEISLER	CORRESPONDENCE	22
+017780	06/08/20	017780	10693	SCDHEC APPROVAL OF THE LETTER HENNESSEY TO KEISLER AND POPE COMPLETION OF BULK WASTE REMOVAL BWR EFFORTS IN TANK 4 JUNE 2011	VAN KEISLER	B. T. HENNESSEY	CORRESPONDENCE	1
+017804	06/21/20	017804	10693	EPA CONCURRENCE FOR COMPLETION OF BULK WASTE REMOVAL BWR EFFORTS IN TANK 4	R. H. POPE	B. T. HENNESSEY	CORRESPONDENCE	2
+017813	06/28/20	017813	10693	EPA SUBMITTAL OF A LIST OF LIQUID WASTE DOCUMENTS BY LETTER FOR FY11 BY JULY 1 2011 REFERENCE LETTER POPE TO HENNESSY APRIL 27 2011	R. H. POPE	B. T. HENNESSEY	CORRESPONDENCE	2
+017827	05/17/20	SRR-CES-2011-00	10693	SRR SUBMITTAL LETTER FOR F AREA TANK FARM GROUNDWATER MONITORING PLAN	P. M. ALLEN	J. DEBESSONET	CORRESPONDENCE	2
+017828	05/01/20	SRNS-RP-2011-00	10693	F AREA TANK FARM GROUNDWATER MONITORING PLAN U MAY 2011	SRNS		SUPPORTING DOCUMENT	28
+017829	06/17/20	017829	10693	SCDHEC COMMENTS ON FAREA TANK FARM GROUNDWATER MONITORING PLAN U SRNS-RP-2011-00995 REVISION 0 MAY 2011 RECEIVED	V. KEISLER	B. T. HENNESSEY	CORRESPONDENCE	2
+017831	06/14/20	017831	10693	EPA COMMENTS ON F AREA TANK FARM GROUNDWATER MONITORING PLAN U SRNS-RP-2011-00995 REV 0 DATED MAY 2011	M. BERRY	V. KEISLER	CORRESPONDENCE	4
+017869	08/11/20	WDPD-11-75	10693	DOE SUBMITTAL OF THE COMPLETION OF BULK WASTE REMOVAL (BWR) EFFORTS IN TANK 7	B. T. HENNESSEY	R. POPE/V. KEISLER	CORRESPONDENCE	2
+017870	08/10/20	SRR-WRC-2011-0	10693	COMPLETION OF TANK 7F BULK WASTE REMOVAL EFFORTS	G. DICKERT/N. DAVIS		SUPPORTING DOCUMENT	20
+017878	08/12/20	WDPD-11-76	10693	DOE SUBMITTAL OF LIQUID WASTE NON-ENFORCEABLE MILESTONES BY LETTER	B. T. HENNESSEY	R. POPE/V. KEISLER	CORRESPONDENCE	4
+017888	08/16/20	017888	10693	EPA APPROVAL OF THE COMPLETION OF BULK WASTE REMOVAL (BWR) EFFORTS IN TANK 7	ROBERT H. POPE	B. T. HENNESSEY	CORRESPONDENCE	2
+017915	09/07/20	WDPD-11-80	10693	DOE SUBMITTAL OF THE APPROVAL TO TRANSFER SUPERNATE INTO TANK 8F	BRIAN HENNESSEY	R.H.POPE/VAN KEISLER	CORRESPONDENCE	2

ARF Index 283

Catalog Num	Date	Doc Number	Track #	Title	Author	Addressee	Doc Type	#of Pages
†-017922	09/14/20	017922	10693	EPA APPROVAL TO TRANSFER SUPERNATE INTO TANK 8F	ROBERT H. POPE	B. T. HENNESSEY	CORRESPONDENCE	1
†-017924	09/14/20	017924	10693	SCDHEC APPROVAL OF THE LETTER, HENNESSEY TO KEISLER AND POPE, APPROVAL TO TRANSFER SUPERNATE INTO TANK 8F, DATED SEPTEMBER 7, 2011	VAN KEISLER	B. T. HENNESSEY	CORRESPONDENCE	1
†-017930	08/17/20	017930	10693	SCDHEC APPROVAL OF THE LETTER, HENNESSEY TO KEISLER AND POPE, COMPLETION OF BULK WASTE REMOVAL (BWR) EFFORTS IN TANK 7, DATED AUGUST 11,	VAN KEISLER	B. T. HENNESSEY	CORRESPONDENCE	1
†-017986	11/02/20	017986	10693	NEWSPAPER ADVERTISEMENT - (THE PEOPLE SENTINEL) - ON THE PUBLIC NOTICE INDUSTRIAL WASTEWATER CLOSURE MODULE FOR THE LIQUID WASTE TANKS 18	SRNS		COMMUNITY INVOLVEMENT	2
†-018033	10/21/20	SRR-CES-2011-00	10693	SRR SUBMITTAL LETTER FOR RESPONSES TO SCDHEC AND EPA REGION 4 COMMENTS F-AREA TANK FARM GROUNDWATER MONITORING PLAN,	P. ALLEN	V. KEISLER	CORRESPONDENCE	9
†-018034	11/09/20	018034	10693	SCDHEC COMMENTS ON THE RESPONSES TO SCDHEC AND EPA REGION 4 COMMENTS ON THE F-AREA TANK FARM GROUNDWATER MONITORING PLAN (U)	V. KEISLER	O. STEVENS	CORRESPONDENCE	2
†-018066	12/14/20	018066	10693	DRAFT F-AREA TANK FARM GROUNDWATER MONITORING PLAN (SRNS-RP-2011-00995, MAY 2011) COMMENT RESPONSES MATRIX FOR THE SCDHEC COMMENTS OF	M. GRIFFITH	M. BERRY/V. KEISLER	CORRESPONDENCE	6
†-018067	01/06/20	018067	10693	SCDHEC COMMENTS ON THE F-AREA TANK FARM GROUNDWATER MONITORING PLAN, SRNS-RP-2011-00995, MAY 2011 RESPONSES TO SCDHEC	V. KEISLER	O. STEVENS	CORRESPONDENCE	5
†-018070	01/01/20	SRNS-RP-2012-00 REV 0	10693	2011 ANNUAL GROUNDWATER MONITORING REPORT FOR THE F- AND H-AREA RADIOACTIVE LIQUID WASTE TANK FARMS (U) SRNS-RP-2012-00022 REVISION 0	SRNS		SUPPORTING DOCUMENT	30
†-018085	10/27/20	SRR-CWDA-2011-	10693	SRR TRANSMITTAL OF THE INDUSTRIAL WASTEWATER CLOSURE MODULE FOR THE LIQUID WASTE TANK 18 AND 19, F-AREA TANK FARM SAVANNAH RIVER SITE,	V.A.FRANKLIN	J.P. deBESSONET	CORRESPONDENCE	3
†-018086	01/27/20	SRR-CWDA-2010- REV 1	10693	INDUSTRIAL WASTEWATER CLOSURE MODULE FOR THE LIQUID WASTE TANKS 18 AND 19 F-AREA TANK FARM, SAVANNAH RIVER SITE	SRR		SUPPORTING DOCUMENT	139
†-018087	01/25/20	SRR-CWDA-2012-	10693	SRR TRANSMITTAL OF THE INDUSTRIAL WASTEWATER CLOSURE MODULE FOR THE LIQUID WASTE TANKS 18 AND 19, F-AREA TANK FARM SAVANNAH RIVER SITE,	V.A.FRANKLIN	J.P.deBESSONE	SUPPORTING DOCUMENT	2
†-018088	01/25/20	SRR-CWDA-2010- REV 2	10693	INDUSTRIAL WASTEWATER CLOSURE MODULE FOR THE LIQUID WASTE TANKS 18 AND 19 F-AREA TANK FARM, SAVANNAH RIVER SITE	SRR		SUPPORTING DOCUMENT	140
†-018089	08/12/20	SRR-CWDA-2011-	10693	SRR TRANSMITTAL OF THE INDUSTRIAL WASTEWATER CLOSURE MODULE FOR THE LIQUID WASTE TANKS 18 AND 19, F-AREA TANK FARM SAVANNAH RIVER SITE,	V.A.FRANKLIN	J.P. deBESSONET	CORRESPONDENCE	2
†-018092	08/12/20	SRR-CWDA-2010- REV 0	10693	INDUSTRIAL WASTEWATER CLOSURE MODULE FOR THE LIQUID WASTE TANKS 18 AND 19 F-AREA TANK FARM SAVANNAH RIVER SITE	SRR		SUPPORTING DOCUMENT	134

ARF Index 283

Catalog Num	Date	Doc Number	Track #	Title	Author	Addressee	Doc Type	#of Pages
+018095	02/01/20	WDPD-12-17	10693	DOE SUBMITTAL OF THE INTERIM ACTION STATEMENT OF BASIS/PROPOSED PLAN FOR THE F-TANK FARM, WASTE TANKS 17 AND 20 (SRR-CWDA-2011-00103, REVISION 0,		R. POPE/V. KEISLER	CORRESPONDENCE	28
+018096	01/01/20	SRR-CWDA-2011-REV 0	10693	INTERIM ACTION STATEMENT OF BASIS/PROPOSED PLAN FOR THE F-AREA TANK FARM, WASTE TANKS 17 AND 20 SRR-CWDA-2011-00103 REVISION 0 CERCLIS NUMBER: 23			INTERIM ACTION PROPOSED PLAN	32
+018097	07/01/20	SRR-CWDA-2011-REDLINE	10693	SCOPING SUMMARY FOR THE F-AREA TANK FARM, WASTE TANKS 17 AND 20 SRR-CWDA-2011-00112 JULY 2011	SRR		SUPPORTING DOCUMENT	21
+018098	01/01/20	SRR-CWDA-2012-	10693	UNITED STATES DEPARTMENT OF ENERGY INTERIM ACTION STATEMENT OF BASIS/PROPOSED PLAN FACT SHEET FOR THE F-AREA TANK FARM WASTE TANKS 17	SRR		SUPPORTING DOCUMENT	3
+018114	02/10/20	018114	10693	SCDHEC COMMENTS ON THE SRS RESPONSES TO SCDHEC AND EPA COMMENTS TO THE FTF GROUNDWATER MONITORING PLAN AND F-AREA TANK	V. KEISLER	O. STEVENS	CORRESPONDENCE	2
+018116	02/01/20	SRR-CES-2012-00	10693	SRR SUBMITTAL LETTER RE: SRS RESPONSES TO SCDHEC AND EPA COMMENTS TO THE FTF GROUNDWATER MONITORING PLAN	P. M. ALLEN	V. KEISLER	CORRESPONDENCE	21
+018117	02/01/20	SRNS-RP-2011-00 REV 1 DRAFT	10693	F-AREA TANK FARM GROUNDWATER MONITORING PLAN (U) SRNS-RP-2011-00995, REV. 1, FEBRUARY 2012 (DRAFT)	SRNS		SUPPORTING DOCUMENT	43
+018120	02/22/20	018120	10693	EPA LETTER IN SUPPORT OF OPERATIONAL CLOSURE OF F-AREA TANK FARM TANKS 18 AND 19		R. POPE B. T. HENNESSEY	CORRESPONDENCE	1
+018122	02/16/20	SRR-CES-2012-00	10693	SRR SUBMITTAL LETTER RE: SRS RESPONSES TO SCDHEC COMMENTS TO THE FTF GROUNDWATER MONITORING PLAN	P. M. ALLEN	V. KEISLER	CORRESPONDENCE	4
+018123	02/01/20	SRNS-RP-2011-00 REV 1 REDLINE	10693	F-AREA TANK FARM GROUNDWATER MONITORING PLAN SRNS-RP-2011-00995 REVISION 1 REDLINE FEBRUARY 2012	SRNS		SUPPORTING DOCUMENT	36
+018124	02/01/20	SRNS-RP-2011-00 REV 1	10693	F-AREA TANK FARM GROUNDWATER MONITORING PLAN SRNS-RP-2011-00995 REVISION 1 FEBRUARY 2012	SRNS		SUPPORTING DOCUMENT	36
+018125	02/24/20	018125	10693	SCDHEC APPROVAL OF THE F-AREA TANK FARM GROUNDWATER MONITORING PLAN SRNS-RP-2011-00995 REVISION 1 FEBRUARY 2012 RECEIVED FEBRUARY 21	V. KEISLER	O. STEVENS	CORRESPONDENCE	1
+018126	02/28/20	WDPD-12-28	10693	DOE SUBMITTAL OF THE CALENDAR YEAR 2011 ANNUAL REPORT STATUS OF F AND H AREA RADIOACTIVE LIQUID WASTE TANKS BEING REMOVED FROM SERVICE	B. T. HENNESSEY	R. POPE/V. KEISLER	CORRESPONDENCE	2
+018127	03/01/20	SRR-CES-2012-00	10693	CALENDAR YEAR 2011 ANNUAL REPORT STATUS OF F AND H AREA RADIOACTIVE LIQUID WASTE TANKS BEING REMOVED FROM SERVICE SRR-CES-2012-00001 DATED	SRR		SUPPORTING DOCUMENT	94
+018134	03/02/20	WDPD-12-27	10693	DOE SUBMITTAL OF THE COMPLETION OF WASTE REMOVAL IN TANKS 18 AND 19	B. T. HENNESSEY	R. POPE/V. KEISLER	CORRESPONDENCE	2

ARF Index 283

Catalog Num	Date	Doc Number	Track #	Title	Author	Addressee	Doc Type	#of Pages
+018141	03/07/20	018141	10693	EPA CONCURRENCE WITH DOE'S LETTER CONCERNING COMPLETION OF WASTE REMOVAL IN TANKS 18 AND 19	R.H. POPE	B. T. HENNESSEY	CORRESPONDENCE	1
+018142	03/07/20	018142	10693	SCDHEC APPROVAL OF SAVANNAH RIVER SITE (F-AREA TANK FARM) 1.INDUSTRIAL WASTEWATER CLOSURE MODULE FOR THE LIQUID WASTE TANKS 18 AND 19,	J.P. deBESSONET	V.A. FRANKLIN	CORRESPONDENCE	1
+018161	03/29/20	018161	10693	SCDHEC APPROVAL OF THE CY2011 ANNUAL REPORT STATUS OF F/H AREA RADIOACTIVE LIQUID WASTE TANKS BEING REMOVED FROM SERVICE	V. KEISLER	B. T. HENNESSEY	CORRESPONDENCE	1
+018165	04/09/20	WDPD-12-40	10693	DOE SUBMITTAL OF LIST OF LIQUID WASTE MILESTONES BY LETTER	B. T. HENNESSEY	R. POPE/V. KEISLER	CORRESPONDENCE	3
+018166	03/29/20	018166	10693	EPA COMMENTS ON INTERIM ACTION STATEMENT OF BASIS PROPOSED PLAN SOB PP FOR THE F AREA TANK FARM WASTE TANKS 17 AND 20 SRR-CWDA-2011-00103	MARTHA BERRY	B. T. HENNESSEY	CORRESPONDENCE	4
+018260	04/17/20	018260	10693	EPA COMMENTS ON THE CY2011 ANNUAL REPORT STATUS OF F H AREA RADIOACTIVE LIQUID WASTE TANKS BEING REMOVED FROM SERVICE	MARTHA BERRY	B. T. HENNESSEY	CORRESPONDENCE	6
+018324	06/01/20	WDPD-12-50	10693	DOE SUBMITTAL OF THE INTERIM ACTION STATEMENT OF BASIS/PROPOSED PLAN FOR THE F TANK FARM WASTE TANKS 17 AND 20 SRR-CWDA-2011-00103 REDLINE	B. T. HENNESSEY	R. H. POPE/V. KEISLER	CORRESPONDENCE	8
+018325	05/01/20	SRR-CWDA-2011-REV 1	10693	INTERIM ACTION STATEMENT OF BASIS/PROPOSED PLAN FOR THE F AREA TANK FARM WASTE TANKS 17 AND 20 CERCLIS NUMBER 23 SRR-CWDA-2011-00103 REVISION 1	SRR		CORRESPONDENCE	33
+018335	01/24/20	LWO-RIP-2009-001 REV 3	10693	INDUSTRIAL WASTEWATER GENERAL CLOSURE PLAN FOR F-AREA WASTE TANK SYSTEMS LWO-RIP-2009-00009 REV 3 DATED JANUARY 24 2011	SRR		SUPPORTING DOCUMENT	53
+018339	01/08/97	PIT-MISC-0002 REV 1	10693	INDUSTRIAL WASTEWATER CLOSURE MODULE FOR THE HIGH-LEVEL WASTE TANK 20 SYSTEM PIT-MISC-0002 REV 1 DATED JANUARY 8 1997	SRNS		SUPPORTING DOCUMENT	165
+018340	08/26/97	PIT-MISC-0004 REV 2	10693	INDUSTRIAL WASTEWATER CLOSURE MODULE FOR THE HIGH-LEVEL WASTE TANK 17 SYSTEM PIT-MISC-0004 REVISION 2 DATED AUGUST 26 1997	SRNS		SUPPORTING DOCUMENT	165
+018359	07/10/96	PIT-MISC-00006 REV 1	10693	INDUSTRIAL WASTEWATER CLOSURE PLAN FOR F AND H AREA HIGH LEVEL WASTE TANK SYSTEMS PIT-MISC-00006 REV 1 DATED JULY 10 1996	SRNS		SUPPORTING DOCUMENT	323
+018386	06/29/20	018386	10693	SCDHEC APPROVAL OF THE INTERIM ACTION STATEMENT OF BASIS PROPOSED PLAN FOR THE F-AREA TANK FARM WASTE TANKS 17 AND 20 CERCLIS NUMBER	V. KEISLER	B. T. HENNESSEY	CORRESPONDENCE	1
+018390	07/03/20	018390	10693	EPA CONCURRENCE OF THE INTERIM ACTION STATEMENT OF BASIS PROPOSED PLAN SOB PP FOR THE F-AREA TANK FARM WASTE TANKS 17 AND 20	M. BERRY	B. T. HENNESSEY	CORRESPONDENCE	1
+018398	07/19/20	018398	10693	EPA APPROVAL OF THE INTERIM ACTION STATEMENT OF BASIS/PROPOSED PLAN SOB/PP FOR THE F AREA TANK FARM WASTE TANKS 17 AND 20 SRR-CWDA-2011-00103	MARTHA BERRY	BRIAN HENNESSEY	CORRESPONDENCE	1

ARF Index 283

Catalog Num	Date	Doc Number	Track #	Title	Author	Addressee	Doc Type	#of Pages
+018411	05/01/20	SRR-CWDA-2011-REV 1	10693	INTERIM ACTION STATEMENT OF BASIS PROPOSED PLAN FOR THE F-AREA TANK FARM WASTE TANKS 17 AND 20 CERCLIS NUMBER 23 SRR-CWDA-2011-00103 REVISION 1	SRR		STATEMENT OF BASIS / PROPOSED PLAN	33
+018412	05/01/20	SRR-CWDA-2012-REV 0	10693	UNITED STATES DEPARTMENT OF ENERGY INTERIM ACTION STATEMENT OF BASIS/PROPOSED PLAN FACT SHEET FOR THE F-AREA TANK FARM WASTE TANKS 17	SRR		SUPPORTING DOCUMENT	3
+018413	08/02/20	SRR-CES-2012-00	10693	SRR SUBMITTAL OF THE F-AREA TANK FARM GROUNDWATER SAMPLING AND ANALYSIS PLAN SRNS-RP-2012-00287 REV 0 AND H-AREA TANK FARM	P. ALLEN	V. KEISLER	CORRESPONDENCE	2
+018414	07/01/20	SRNS-RP-2012-00	10693	F-AREA TANK FARM GROUNDWATER SAMPLING AND ANALYSIS PLAN SRNS-RP-2012-00287 REVISION 0 JULY 2012	SRNS		SUPPORTING DOCUMENT	64
+018436	08/14/20	018436	10693	NEWSPAPER ADVERTISEMENT AIKEN STANDARD ON THE INTERIM ACTION STATEMENT OF BASIS PROPOSED PLAN FOR THE F-AREA TANK FARM WASTE TANKS 17 AND 20	SRNS		COMMUNITY INVOLVEMENT	1
+018437	08/15/20	018437	10693	NEWSPAPER ADVERTISEMENT THE PEOPLE SENTINEL ON THE INTERIM ACTION STATEMENT OF BASIS PROPOSED PLAN FOR THE F-AREA TANK FARM WASTE	SRNS		COMMUNITY INVOLVEMENT	2
+018452	09/05/20	WDPD-12-75	10693	DOE SUBMITTAL OF THE COMPLETION OF OPERATIONAL CLOSURE OF TANKS 19 AND 18	BRIAN T. HENNESSEY	ROBERT H. POPE/VAN KEISLER	CORRESPONDENCE	2
+018455	08/30/20	018455	10693	SCDHEC AND EPA COMMENTS ON THE F-AREA TANK FARM GROUNDWATER SAMPLING AND ANALYSIS PLAN SRNS-RP-2012-00287 REVISION 0 JULY 2012	V. KEISLER	B. HENNESSEY	CORRESPONDENCE	8
+018462	08/14/20	018462	10693	NEWSPAPER ADVERTISEMENT THE STATE ON THE INTERIM ACTION STATEMENT OF BASIS/PROPOSED PLAN F-AREA TANK FARM WASTE TANKS 17 AND 20 AT THE	SRNS		COMMUNITY INVOLVEMENT	2
+018464	08/31/20	018464	10693	RADIO ANNOUNCEMENT WKXC-FM ON THE INTERIM ACTION STATEMENT OF BASIS/PROPOSED PLAN F-AREA TANK FARM WASTE TANKS 17 AND 20	SRNS		COMMUNITY INVOLVEMENT	1
+018490	08/14/20	018490	10693	NEWSPAPER ADVERTISEMENT THE AUGUSTA CHRONICLE ON THE INTERIM ACTION STATEMENT OF BASIS/PROPOSED PLAN F-AREA TANK FARM WASTE	SRNS		COMMUNITY INVOLVEMENT	2
+018492	09/19/20	018492	10693	SCDHEC RESPONSE TO LETTER HENNESSEY TO KEISLER AND POPE COMPLETION OF OPERATIONAL CLOSURE OF TANKS 19 AND 18 DATED SEPTEMBER 5,	V. KEISLER	B. HENNESSEY	CORRESPONDENCE	1
+018526	10/11/20	WDPD-13-03	10693	DOE SUBMITTAL OF THE INTERIM RECORD OF DECISION REMEDIAL ALTERNATIVE SELECTION FOR THE F AREA TANK FARM WASTE TANKS 17 AND 20 U	BRIAN T. HENNESSEY	ROBERT H. POPE/VAN KEISLER	CORRESPONDENCE	2
+018527	10/01/20	SRR-CWDA-2012-	10693	INTERIM RECORD OF DECISION REMEDIAL ALTERNATIVE SELECTION FOR THE F AREA TANK FARM WASTE TANKS 17 AND 20 U CERCLIS NUMBER 23 SRR-CWDA-2012-00111	SRNS		SUPPORTING DOCUMENT	54
+018528	09/19/20	018528	10693	EPA RESPONSE TO LETTER HENNESSEY TO KEISLER AND POPE COMPLETION OF OPERATIONAL CLOSURE OF TANKS 19 AND 18 DATED SEPTEMBER 5 2012	ROBERT H. POPE	BRIAN T. HENNESSEY	CORRESPONDENCE	2

ARF Index 283

Catalog Num	Date	Doc Number	Track #	Title	Author	Addressee	Doc Type	#of Pages
+018572	12/10/20	018572	10693	SCDHEC APPROVAL OF THE F AREA TANK FARM GROUNDWATER SAMPLING AND ANALYSIS PLAN U SRNS-RP-2012-00287 REVISION 1 NOVEMBER 2012	VAN KEISLER	BRIAN T. HENNESSEY	CORRESPONDENCE	1
+018618	11/29/20	018618	10693	EPA APPROVAL OF THE F AREA TANK FARM GROUNDWATER SAMPLING AND ANALYSIS PLAN U SRNS-RP-2012-00287 REVISION 1 NOVEMBER 2012 AND H	MARTHA BERRY	VAN KEISLER	CORRESPONDENCE	1
+018619	12/11/20	018619	10693	EPA COMMENTS ON THE INTERIM RECORD OF DECISION (IROD) REMEDIAL ALTERNATIVE SELECTION FOR THE F-AREA TANK FARM, WASTE TANKS 17 AND 20,	MARTHA BETTY	BRIAN T. HENNESSEY	CORRESPONDENCE	2
+018621	12/10/20	018621	10693	SCDHEC COMMENTS ON THE INTERIM RECORD OF DECISION/REMEDIAL ALTERNATIVE SELECTION FOR THE F-AREA TANK FARM, WASTE TANKS 17 AND 20 (U),	VAN KEISLER	BRIAN T. HENNESSEY	CORRESPONDENCE	2
+018669	01/01/20	SRR-CWDA-2012-REV 0	10693	INDUSTRIAL WASTEWATER CLOSURE MODULE FOR THE LIQUID WASTE TANKS 5F AND 6F F-AREA TANK FARM SAVANNAH RIVER SITE PERMIT NO 17,424-IW	SRR		SUPPORTING DOCUMENT	181
+018689	02/15/20	WDPD-13-33	10693	DOE SUBMITTAL OF THE INTERIM RECORD OF DECISION REMEDIAL ALTERNATIVE SELECTION FOR THE F-AREA TANK FARM WASTE TANKS 17 AND 20	BRIAN T. HENNESSEY	ROBERT H. POPE VAN KEISLER	CORRESPONDENCE	4
+018690	01/01/20	SRR-CWDA-2012-REV 1 REDLINE	10693	INTERIM RECORD OF DECISION REMEDIAL ALTERNATIVE SELECTION FOR THE F-AREA TANK FARM WASTE TANKS 17 AND 20 SRR-CWDA-2012-00111 REVISION 1 REDLINE	SRR		SUPPORTING DOCUMENT	55
+018708	02/27/20	WDPD-13-36	10693	DOE SUBMITTAL OF THE CALENDAR YEAR CY2012 ANNUAL REPORT STATUS OF F/H AREA RADIOACTIVE LIQUID WASTE TANKS BEING REMOVED FROM SERVICE	BRIAN T. HENNESSEY	ROBERT H. POPE VAN KEISLER	CORRESPONDENCE	2
+018709	03/01/20	SRR-ESH-2013-00	10693	CY2012 ANNUAL REPORT STATUS OF F/H AREA RADIOACTIVE LIQUID WASTE TANKS BEING REMOVED FROM SERVICE SRR-ESH-2013-00005 MARCH 2013	SRR		SUPPORTING DOCUMENT	37
+018711	03/01/20	WDPD-13-35	10693	DOE SUBMITTAL OF THE APPROVAL FOR CONTINUED USAGE OF HIGH LEVEL WASTE TANKS 7F AND 11H	BRIAN T. HENNESSEY	ROBERT H. POPE VAN KEISLER	CORRESPONDENCE	2
+018712	02/21/20	SRR-LWP-2013-00	10693	ADDITIONAL TYPE I TANK USAGE POST-BULK WASTE REMOVAL EFFORTS BWRE BRIEFING TO SCDHEC AND EPA SRR-LWP-2013-00012	MARK MAHONEY KARTHIK SUBRAMANIAN JASON VITALI		SUPPORTING DOCUMENT	32
+018723	02/19/20	018723	10693	NEWSPAPER ADVERTISEMENT THE AUGUSTA CHRONICLE INDUSTRIAL WASTEWATER CLOSURE MODULE FOR LIQUID WASTE TANKS 5F AND 6F F-AREA	SRR		SUPPORTING DOCUMENT	1
+018724	02/19/20	018724	10693	NEWSPAPER ADVERTISEMENT AIKEN STANDARD INDUSTRIAL WASTEWATER CLOSURE MODULE FOR LIQUID WASTE TANKS 5F AND 6F F-AREA TANK FARM	SRNS		SUPPORTING DOCUMENT	1
+018728	03/07/20	018728	10693	EPA APPROVAL OF THE LETTER HENNESSEY TO KEISLER AND POPE APPROVAL FOR CONTINUED USAGE OF HIGH LEVEL WASTE TANKS 7F AND 11H DATED MARCH 1 2013	ROBERT H. POPE	BRIAN T. HENNESSEY	CORRESPONDENCE	2
+018729	03/07/20	018729	10693	SCDHEC APPROVAL OF THE LETTER HENNESSEY TO KEISLER AND POPE APPROVAL FOR CONTINUED USAGE OF HIGH LEVEL WASTE TANKS 7F AND 11H DATED	VAN KEISLER	BRIAN T. HENNESSEY	CORRESPONDENCE	1

ARF Index 283

Catalog Num	Date	Doc Number	Track #	Title	Author	Addressee	Doc Type	#of Pages
+018749	03/18/20	ARF-018749	10693	EPA APPROVAL OF THE INTERIM RECORD OF DECISION (IROD) REMEDIAL ALTERNATIVE SELECTION FOR THE F-AREA TANK FARM WASTE TANKS 17 AND 20	MARTHA BERRY	BRIAN HENNESSEY	CORRESPONDENCE	1
+018750	03/14/20	ARF-018750	10693	SCDHEC APPROVAL OF THE INTERIM RECORD OF DECISION / REMEDIAL ALTERNATIVE SELECTION FOR THE F-AREA TANK FARM WASTE TANKS 17 AND 20 (U)	VAN KEISLER	BRIAN T. HENNESSEY	CORRESPONDENCE	1
+018752	03/11/20	WDPD-13-39	10693	DOE SUBMITTAL OF THE EXPLANATION OF SIGNIFICANT DIFFERENCE ESD FOR THE REVISION 1 INTERIM RECORD OF DECISION REMEDIAL ALTERNATIVE SELECTION FOR THE F AREA TANK FARM WASTE TANKS 17 AND 20 U	BRIAN T. HENNESSEY	ROBERT H. POPE VAN KEISLER	CORRESPONDENCE	2
+018753	03/01/20	SRR-CWDA-2013-REV 0	10693	EXPLANATION OF SIGNIFICANT DIFFERENCE ESD FOR THE REVISION 1 INTERIM RECORD OF DECISION REMEDIAL ALTERNATIVE SELECTION FOR THE F AREA TANK FARM WASTE TANKS 17 AND 20 U	SRR		SUPPORTING DOCUMENT	15
+018761	03/25/20	018761	10693	DOE SUBMITTAL OF THE SIGNED INTERIM RECORD OF DECISION REMEDIAL ALTERNATIVE SELECTION FOR THE F TANK FARM WASTE TANKS 17 AND 20 U	BRIAN T. HENNESSEY	VAN KEISLER ROBERT H. POPE	CORRESPONDENCE	2
+018762	01/01/20	SRR-CWDA-2012-REV 1	10693	INTERIM RECORD OF DECISION REMEDIAL ALTERNATIVE SELECTION FOR THE F AREA TANK FARM WASTE TANKS 17 AND 20 U CERCLIS NUMBER 23 SRR-CWDA-2012-00111	SRR		SUPPORTING DOCUMENT	54
+018923	04/15/20	018923	10693	SCDHEC SUBMITTAL OF THE SIGNED INTERIM RECORD OF DECISION/REMEDIAL ALTERNATIVE SELECTION FOR THE F-AREA TANK FARM WASTE TANKS 17 AND 20	VAN KEISLER	BRIAN T. HENNESSEY	CORRESPONDENCE	1
+018924	01/01/20	SRR-CWDA-2012-REV 1	10693	THREE PARTY SIGNED INTERIM RECORD OF DECISION REMEDIAL ALTERNATIVE SELECTION FOR THE F-AREA TANK FARM WASTE TANKS 17 AND 20 CERCLIS NUMBER	SRR		SUPPORTING DOCUMENT	54
+018934	04/02/20	018934	10693	EPA SUBMITTAL OF THE INTERIM RECORD OF DECISION IROD REMEDIAL ALTERNATIVE SELECTION FOR THE F-AREA TANK FARM WASTE TANKS 17 AND 20	MARTHA BERRY	VAN KEISLER	CORRESPONDENCE	2
+018938	04/26/20	WDPD-13-50	10693	DOE SUBMITTAL OF THE COMPLETION OF WASTE REMOVAL IN TANKS 5 AND 6 CERCLIS NUMBER 23	BRIAN T. HENNESSEY	ROBERT H. POPE VAN KEISLER	CORRESPONDENCE	2
+018946	05/02/20	018946	10693	DOE SUBMITTAL OF THE THREE PARTY SIGNED INTERIM RECORD OF DECISION REMEDIAL ALTERNATIVE SELECTION FOR THE F TANK FARM WASTE TANKS 17	BRIAN T. HENNESSEY	ROBERT H. POPE VAN KEISLER	SUPPORTING DOCUMENT	2
+018951	03/27/20	SRR--ESH-2013-0	10693	2012 ANNUAL GROUNDWATER MONITORING REPORT U	PATRICIA M ALLEN	VAN KEISLER	CORRESPONDENCE	3
+018952	03/01/20	SRNS-RP-2013-00 REV 0	10693	2012 ANNUAL GROUNDWATER MONITORING REPORT FOR THE F AND H AREA RADIOACTIVE LIQUID WASTE TANK FARMS U CERCLIS NUMBER 23 & 89	SRNS		SUPPORTING DOCUMENT	68
+018994	05/06/20	018994	10693	SCDHEC COMMENTS ON THE 2012 ANNUAL GROUNDWATER MONITORING REPORT U CERCLIS NUMBER 28 AND 89 SRNS-RP-2013-00118 REVISION 0	VAN KEISLER	PATRICIA M ALLEN	CORRESPONDENCE	2
+018996	05/07/20	018996	10693	SCDHEC COMMENTS ON THE EXPLANATION OF SIGNIFICANT DIFFERENCE ESD FOR THE REVISION 1 INTERIM RECORD OF DECISION REMEDIAL ALTERNATIVE	VAN KEISLER	BRIAN T. HENNESSEY	CORRESPONDENCE	2

ARF Index 283

Catalog Num	Date	Doc Number	Track #	Title	Author	Addressee	Doc Type	#of Pages
+018997	05/08/20	018997	10693	EPA CONCURRENCE OF THE EXPLANATION OF SIGNIFICANT DIFFERENCE ESD FOR THE REVISION 1	MARTHA BERRY	BRIAN T. HENNESSEY	CORRESPONDENCE	1
+019003	05/14/20	019003	10693	INTERM RECORD OF DECISION REMEDIAL ALTERNATIVE EPA COMMENTS ON THE 2012 ANNUAL GROUNDWATER MONITORING REPORT FOR THE F AND H AREA	MARTHA BERRY	PATRICIA M. ALLEN	CORRESPONDENCE	2
+019011	05/16/20	SRNS-OS-2013-00	10693	RADIOACTIVE LIQUID WASTE TANK FARMS SCDHEC LETTER REGARDING SAVANNAH RIVER SITE SC1 890 008 989 FINAL PERMIT DECISION FOR B AREA OPERABLE UNIT AND THE F AREA TANK FARM WASTE	RICHARD HAYNES	KEVIN M. KOSTELNIK	CORRESPONDENCE	10
+019012	05/15/20	019012	10693	SCDHEC AGREEMENT REGARDING COMPLETION OF WASTE REMOVAL IN TANKS 5 AND 6 LETTER HENNESSEY TO KEISLER AND POPE DATED APRIL 26 2013 CERCLIS	VAN KEISLER	BRIAN T. HENNESSEY	CORRESPONDENCE	1
+019021	04/30/20	019021	10693	NEWSPAPER ADVERTISEMENT AIKEN STANDARD PUBLIC NOTICE - NOTICE OF AVAILABILITY INTERIM RECORD OF DECISION FOR THE F-AREA TANK FARM WASTE TANKS 17	SRNS		COMMUNITY INVOLVEMENT	1
+019022	05/01/20	019022	10693	NEWSPAPER ADVERTISEMENT THE PEOPLE SENTINEL PUBLIC NOTICE - NOTICE OF AVAILABILITY INTERIM RECORD OF DECISION FOR THE F-AREA TANK FARM	SRNS		COMMUNITY INVOLVEMENT	2
+019023	04/30/20	019023	10693	NEWSPAPER ADVERTISEMENT THE STATE PUBLIC NOTICE - NOTICE OF AVAILABILITY INTERIM RECORD OF DECISION FOR THE F-AREA TANK FARM WASTE TANKS 17	SRNS		COMMUNITY INVOLVEMENT	2
+019030	06/05/20	019030	10693	DOE SUBMITTAL OF THE EXPLANATION OF SIGNIFICANT DIFFERENCE (ESD) FOR INCORPORATING TANKS 18 AND 19 INTO THE REVISION 1 INTERIM RECORD OF DECISION	BRIAN T. HENNESSEY	ROBERT H. POPE VAN KEISLER	CORRESPONDENCE	3
+019031	05/01/20	SRR-CWDA-2013-REDLINE REV 1	10693	EXPLANATION OF SIGNIFICANT DIFFERENCE (ESD) FOR INCORPORATING TANKS 18 AND 19 INTO THE REVISION 1 INTERIM RECORD OF DECISION REMEDIAL ALTERNATIVE	SRR		SUPPORTING DOCUMENT	15
+019032	05/15/20	019032	10693	EPA AGREEMENT REGARDING COMPLETION OF WASTE REMOVAL IN TANKS 5 AND 6 LETTER HENNESSEY TO KEISLER AND POPE DATED APRIL 26 2013 CERCLIS	ROBERT H. POPE	BRIAN T. HENNESSEY	CORRESPONDENCE	2
+019048	06/21/20	019048	10693	DOE SUBMITTAL OF THE INTERIM CORRECTIVE MEASURES IMPLEMENTATION/REMEDIAL ACTION IMPLEMENTATION PLAN (ICMI/RAIP) FOR THE F-AREA	BRIAN T. HENNESSEY	ROBERT H. POPE/ VAN KEISLER	CORRESPONDENCE	2
+019049	06/01/20	SRR-CWDA-2013-REV 0	10693	INTERIM CORRECTIVE MEASURES IMPLEMENTATION/REMEDIAL ACTION IMPLEMENTATION PLAN (ICMI/RAIP) FOR THE F-AREA TANK FARM, WASTE	SRR		SUPPORTING DOCUMENT	22
+019065	07/01/20	019065	10693	SCDHEC COMMENTS ON THE EXPLANATION OF SIGNIFICANT DIFFERENCE (ESD) FOR INCORPORATING TANKS 18 AND 19 INTO THE REVISION 1 INTERIM RECORD	VAN KEISLER	BRIAN T. HENNESSEY	CORRESPONDENCE	2
+019077	07/12/20	WDPD-13-73	10693	DOE SUBMITTAL OF THE NEED FOR CONTINUED USAGE OF HIGH LEVEL WASTE TANKS 4F AND 7F	BRIAN T. HENNESSEY	ROBERT H. POPE/ VAN KEISLER	CORRESPONDENCE	6
+019078	06/01/20	SRR-LWP-2013-00	10693	SAVANNAH RIVER SITE LIQUID WASTE PROGRAM PAST PROGRESS AND FUTURE PROSPECT	SRR		SUPPORTING DOCUMENT	21

ARF Index 283

Catalog Num	Date	Doc Number	Track #	Title	Author	Addressee	Doc Type	#of Pages
†-019079	06/01/20	SRR-LWP-2013-00 REV 0	10693	ADDITIONAL TYPE I TANK USAGE POST-BULK WASTE REMOVAL EFFORTS (BWRE)	SRR		SUPPORTING DOCUMENT	32
†-019080	06/17/20	SRR-LWP-2013-00	10693	FOLLOWUP FROM JUNE 6 DISCUSSION REGARDING LW SYSTEM PLAN DRAFT REV. 18 RESULTS	SRR		SUPPORTING DOCUMENT	15
†-019084	07/19/20	WDPD-13-74	10693	DOE SUBMITTAL OF THE U.S. DEPARTMENT OF ENERGY SIGNED EXPLANATION OF SIGNIFICANT DIFFERENCE ESD FOR INCORPORATING TANKS 18 AND 19 INTO THE	BRIAN T. HENNESSEY	ROBERT H. POPE VAN KEISLER	SUPPORTING DOCUMENT	3
†-019085	07/01/20	SRR-CWDA-2013- REV 1.1	10693	U.S. DEPARTMENT OF ENERGY SIGNED EXPLANATION OF SIGNIFICANT DIFFERENCE ESD FOR INCORPORATING TANKS 18 AND 19 INTO THE REVISION 1 INTERIM RECORD	SRR		SUPPORTING DOCUMENT	16
†-019094	08/06/20	WDPD-13-77	10693	DOE SUBMITTAL OF THE SUBMITTAL OF LIST OF LIQUID WASTE MILESTONES BY LETTER	HENNESSEY,BRIAN T	ROBERT H. POPE, VAN KEISLER	CORRESPONDENCE	3
†-019105	08/15/20	019105	10693	EPA SUBMITTAL OF THE EXPLANATION OF SIGNIFICANT DIFFERENCE (ESD) FOR INCORPORATING TANKS 18 AND 19 INTO THE REVISION 1 INTERIM RECORD OF DECISION	MARTHA BERRY	VAN KEISLER	CORRESPONDENCE	2
†-019109	08/26/20	019109	10693	SCDHEC SUBMITTAL OF THE SIGNED EXPLANATION OF SIGNIFICANT DIFFERENCE ESD FOR INCORPORATING TANKS 18 AND 19 INTO THE REVISION 1 INTERIM RECORD	VAN KEISLER	BRIAN T. HENNESSEY	CORRESPONDENCE	1
†-019110	07/01/20	SRR-CWDA-2013- REV 1.1	10693	THREE PARTY SIGNED EXPLANATION OF SIGNIFICANT DIFFERENCE ESD FOR INCORPORATING TANKS 18 AND 19 INTO THE REVISION 1 INTERIM RECORD OF DECISION	SRR		RECORD OF DECISION	16
†-019112	09/04/20	019112	10693	EPA COMMENTS ON THE INTERIM CORRECTIVE MEASURES IMPLEMENTATION/REMEDIAL ACTION IMPLEMENTATION PLAN (ICMI/RAIP) FOR THE F-AREA	MARTHA BERRY	BRIAN T. HENNESSEY	CORRESPONDENCE	4
†-019124	09/12/20	019124	10693	SCDHEC APPROVAL OF THE INTERIM CORRECTIVE MEASURES IMPLEMENTATION / REMEDIAL ACTION IMPLEMENTATION PLAN (ICMI/RAIP) FOR THE F-AREA	VAN KEISLER	BRIAN T. HENNESSEY	CORRESPONDENCE	1
†-019139	09/27/20	WDPD-13-88	10693	DOE SUBMITTAL OF THE THREE PARTY SIGNED EXPLANATION OF SIGNIFICANT DIFFERENCE ESD FOR INCORPORATING TANKS 18 AND 19 INTO THE REVISION 1	BRIAN T. HENNESSEY	ROBERT H. POPE VAN KEISLER	CORRESPONDENCE	2
†-019164	10/10/20	019164	10693	SCDHEC APPROVAL OF THE 2012 ANNUAL GROUNDWATER MONITORING REPORT FOR THE F AREA	VAN KEISLER	PATRICIA M ALLEN	CORRESPONDENCE	1
†-019166	10/02/20	SRNS-OS-2013-00	10693	AND H AREA RADIOACTIVE LIQUID WASTE TANK FARM U SCDHEC LETTER RE: SAVANNAH RIVER SITE - SC1 890 008 989 FINAL PERMIT DECISION FOR F AREA TANK FARM WASTE TANKS 18 AND 19	RICHARD HAYNES	KEVIN M KOSTELNIK	CORRESPONDENCE	8
†-019170	10/02/20	019170	10693	SCDHEC RESPONSE TO JULY 12 2013 LETTER HENNESSEY TO KEISLER AND POPE NEED FOR CONTINUED USAGE OF HIGH LEVEL WASTE TANKS 4F	VAN KEISLER	BRIAN T. HENNESSEY	CORRESPONDENCE	2
†-019173	09/10/20	SRR-ESH-2013-00	10693	REVISION TO THE 2012 ANNUAL GROUNDWATER MONITORING REPORT U	PATRICIA M. ALLEN	MARTHA BERRY VAN KEISLER	SUPPORTING DOCUMENT	3

ARF Index 283

Catalog Num	Date	Doc Number	Track #	Title	Author	Addressee	Doc Type	#of Pages
+019174	06/21/20	SRR-ESH-2013-0C	10693	RESPONSE TO COMMENTS ON 2012 ANNUAL GROUNDWATER MONITORING REPORT U	PATRICIA M. ALLEN	MARTHA BERRY VAN KEISLER	SUPPORTING DOCUMENT	8
+019175	07/01/20	SRNS-RP-2013-0C REV 1	10693	2012 ANNUAL GROUNDWATER MONITORING REPORT FOR THE F AND H AREA RADIOACTIVE LIQUID WASTE TANK FARMS U CERCLIS NUMBER 23 & 89	SRNS		SUPPORTING DOCUMENT	60
+019247	11/19/20	019247	10693	EPA RESPONSE TO JULY 12 2013 LETTER HENNESSEY TO KEISLER AND POPE NEED FOR CONTINUED USAGE OF HIGH LEVEL WASTE TANKS 4F AND 7F	ROBERT H. POPE	BRIAN T. HENNESSEY	CORRESPONDENCE	2
+019258	12/19/20	WDPD-14-16	10693	DOE SUBMITTAL OF THE COMPLETE OPERATIONAL CLOSURE OF TANKS 5 AND 6	BRIAN T. HENNESSEY	VAN KEISLER	CORRESPONDENCE	2
+019261	12/17/20	WDPD-14-11	10693	DOE SUBMITTAL OF THE INTERIM CORRECTIVE MEASURES IMPLEMENTATION/REMEDIAL ACTION IMPLEMENTATION PLAN (ICMI/RAIP) FOR THE F-AREA INTERIM CORRECTIVE MEASURES	BRIAN T. HENNESSEY	ROBERT H. POPE VAN KEISLER	CORRESPONDENCE	2
+019262	12/01/20	SRR-CWDA-2013- REDLINE REV 1	10693	IMPLEMENTATION/REMEDIAL ACTION IMPLEMENTATION PLAN (ICMI/RAIP) FOR THE F-AREA TANK FARM WASTE INTERIM CORRECTIVE MEASURES	SRR		SUPPORTING DOCUMENT	26
+019263	12/01/20	SRR-CWDA-2013- REV 0	10693	IMPLEMENTATION/REMEDIAL ACTION IMPLEMENTATION PLAN (ICMI/RAIP) FOR THE F-AREA TANK FARM WASTE INTERIM CORRECTIVE MEASURES	SRR		SUPPORTING DOCUMENT	7
+019298	01/16/20	019298	10693	SCDHEC APPROVAL OF THE INTERIM CORRECTIVE MEASURES IMPLEMENTATION/REMEDIAL ACTION IMPLEMENTATION PLAN (ICMI/RAIP) FOR THE F-AREA	VAN KEISLER	BRIAN HENNESSEY	CORRESPONDENCE	1
+019300	01/16/20	019300	10693	EPA THIRTY-DAY EXTENSION NOTIFICATION FOR THE INTERIM CORRECTIVE MEASURES	MARTHA BERRY	BRIAN T. HENNESSEY	CORRESPONDENCE	1
+019304	01/22/20	019304	10693	IMPLEMENTATION/REMEDIAL ACTION IMPLEMENTATION PLAN (ICMI/RAIP) FOR THE F-AREA	VAN KEISLER	BRIAN T. HENNESSEY	CORRESPONDENCE	1
+019308	11/06/20	SRR-CWDA-2013-	10693	SCDHEC CONCURRENCE ON THE LETTER, HENNESSEY TO KEISLER AND POPE, COMPLETION OF OPERATIONAL CLOSURE OF TANKS 5 AND 6 DATED DECEMBER 19, 2013	SRR		SUPPORTING DOCUMENT	3
+019309	01/27/20	SRR-CWDA-2014-	10693	REQUEST TO REMOVE TANKS 241-918F AND 241-919F FROM CONSTRUCTION PERMIT NO. 71, 424-IW: F AND H-AREA HIGH LEVEL RADIOACTIVE WASTE TANK FARMS	SRR		SUPPORTING DOCUMENT	3
+019321	01/23/20	019321	10693	REQUEST TO REMOVE TANKS 241-918F AND 241-919F FROM CONSTRUCTION PERMIT No. 17,424-IW: F AND H AREA HIGH LEVEL RADIOACTIVE WASTE TANK FARMS	ROBERT H POPE	BRIAN T. HENNESSEY	CORRESPONDENCE	1
+019327	02/26/20	WDPD-14-28	10693	EPA CONCURRENCE ON THE LETTER HENNESSEY TO KEISLER AND POPE COMPLETION OF OPERATIONAL CLOSURE OF TANKS 5 AND 6 DATED DECEMBER 19 2013	JEAN M. RIDLEY	ROBERT H. POPE/SHELLY WILSON	CORRESPONDENCE	4
+019340	02/18/20	019340	10693	DOE SUBMITTAL OF THE SAVANNAH RIVER SITE LIQUID WASTE SYSTEM PLAN INPUT AND ASSUMPTIONS	MARHTA BERRY	BRIAN T. HENNESSEY	CORRESPONDENCE	1
				EPA CONDITIONAL APPROVAL OF THE INTERIM CORRECTIVE MEASURES IMPLEMENTATION/REMEDIAL ACTION IMPLEMENTATION PLAN ICMI/RAIP FOR THE F				

ARF Index 283

Catalog Num	Date	Doc Number	Track #	Title	Author	Addressee	Doc Type	#of Pages
†-019348	03/05/20	WDPD-14-27	10693	DOE SUBMITTAL OF THE CALENDAR YEAR CY 2013 ANNUAL REPORT STATUS OF F/H AREA RADIOACTIVE LIQUID WASTE TANKS BEING REMOVED FROM SERVICE	BRIAN T. HENNESSEY	ROBERT H. POPE VAN KEISLER	CORRESPONDENCE	2
†-019351	03/01/20	SRR-ESH-2014-00	10693	CALENDAR YEAR CY 2013 ANNUAL REPORT STATUS OF F/H AREA RADIOACTIVE LIQUID WASTE TANKS BEING REMOVED FROM SERVICE	SRR		SUPPORTING DOCUMENT	51
†-019353	03/05/20	SRR-CWDA-2013-	10693	FACT SHEET FOR THE INTERIM REMEDIAL ACTION FOR F-AREA TANK FARM FTF STABILIZED WASTE TANKS 17 THROUGH 20	LAMESHA PRESSLEY		SUPPORTING DOCUMENT	2
†-019392	03/26/20	WDPD-14-35	10693	DOE SUBMITTAL OF THE EXPLANATION OF SIGNIFICANT DIFFERENCE ESD FOR INCORPORATING TANKS 5 AND 6 INTO THE REVISION 1 INTERIM RECORD OF DECISION	BRIAN T. HENNESSEY	ROBERT H. POPE SUSAN B. FULMER	CORRESPONDENCE	2
†-019393	03/01/20	SRR-CWDA-2014-REV 0	10693	EXPLANATION OF SIGNIFICANT DIFFERENCE ESD FOR INCOPORATING TANKS 5 AND 6 INTO THE REVISION 1 INTERIM RECORD OF DECISION	SRR		SUPPORTING DOCUMENT	15
†-019394	03/26/20	WDPD-14-34	10693	DOE SUBMITTAL OF THE INTERIM CORRECTIVE MEASURES IMPLEMENTATION / REMEDIAL ACTION IMPLEMENTATION PLAN ICMI/RAIP FOR THE F AREA TANK	BRIAN T. HENNESSEY	ROBERT H. POPE SUSAN B. FULMER	CORRESPONDENCE	2
†-019395	12/01/20	SRR-CWDA-2013-REV 1	10693	INTERIM CORRECTIVE MEASURES IMPLEMENTATION / REMEDIAL ACTION IMPLEMENTATION PLAN ICMI/RAIP FOR THE F AREA TANK FARM WASTE TANKS 17 THROUGH	SRR		SUPPORTING DOCUMENT	27
†-019562	05/08/20	019562	10693	SCDHEC APPROVAL OF THE 2013 ANNUAL GROUNDWATER MONITORING REPORT FOR THE F AND H AREA RADIOACTIVE LIQUID WASTE TANK FARMS U	SUSAN B. FULMER	PATRICIA M. ALLEN	CORRESPONDENCE	1
†-019570	04/02/20	019570	10693	SCDHEC LETTER REGARDING CLOSURE AND REMOVAL OF TANKS 18 AND 19 FROM CONSTRUCTION PERMIT NO. 17, 424-1W F AND H AREA THIGH LEVE RADIOACTIVE	JEFFREY P. deBESSONET	VICTOR A. FRANKLIN	CORRESPONDENCE	2
†-019571	03/14/20	019571	10693	SCDHEC LETTER RE: REQUEST TO REMOVE TANKS 241-918F AND 241-919F FROM CONSTRUCTION PERMIT NO. 17, 424-1W: F AND H AREA HIGH LEVEL RADIOACTIVE	JOSHUA C. YON	VICTOR A. FRANKLIN	CORRESPONDENCE	1
†-019580	03/19/20	019580	10693	THE SAVANNAH RIVER SITE ENVIRONMENTAL BULLETIN FOR THE NOTICE OF AVAILABILITY FOR THE FACT SHEET AVAILABLE FOR THE F AREA TANK FARM STABILIZED	SRNS		COMMUNITY INVOLVEMENT	2
†-019582	05/19/20	WDPD-14-42	10693	DOE SUBMITTAL OF THE NOTIFICATION OF THE INTERIM REMEDIAL ACTION COMPLETION FOR F AREA TANK FARM WASTE TANKS 17 THROUGH 20 CERCLIS NUMBER 23	BRIAN T. HENNESSEY	ROBERT H. POPE SUSAN B. FULMER	CORRESPONDENCE	2
†-019588	04/30/20	019588	10693	THE ENVIRONMENTAL BULLETIN FROM THE SAVANNAH RIVER SITE FOR THE NOTICE OF AVAILABILITY FOR THE INTERM RECORD OF DECISION FOR THE F-AREA TANK	SRNS		COMMUNITY INVOLVEMENT	2
†-019596	08/14/20	019596	10693	THE ENVIRONMENTAL BULLETIN FROM THE SAVANNAH RIVER SITE FOR THE INTERIM ACTION STATEMENT OF BASIS/PROPOSED PLAN F-AREA TANK FARM WASTE	SRNS		COMMUNITY INVOLVEMENT	2
†-019606	03/09/20	019606	10693	THE ENVIRONMENTAL BULLETIN FROM THE SAVANNAH RIVER SITE FOR THE ACTION MEMORANDUM AND RESPONSIVENESS SUMMARY ISSUED FOR THE C AREA	SRNS		COMMUNITY INVOLVEMENT	2

ARF Index 283

Catalog Num	Date	Doc Number	Track #	Title	Author	Addressee	Doc Type	#of Pages
+019607	05/21/20	019607	10693	SCDHEC COMMENTS ON THE EXPLANATION OF SIGNIFICANT DIFFERENCE ESD FOR INCORPORATING TANKS 5 AND 6 INTO THE REVISION 1 INTERIM RECORD	SUSAN B. FULMER	BRIAN T. HENNESSEY	CORRESPONDENCE	2
+019634	10/31/20	019364	10693	THE ENVIRONMENTAL BULLETIN FROM THE SAVANNAH RIVER SITE INDUSTRIAL WASTEWATER CLOSURE MODULE FOR THE LIQUID WASTE TANKS 18 AND 19 F	SRNS		COMMUNITY INVOLVEMENT	2
+019641	05/27/20	019641	10693	EPA APPROVAL OF THE EXPLANATION OF SIGNIFICANT DIFFERENCES ESD FOR INCORPORATING TANKS 5 AND 6 INTO THE REVISION 1 INTERIM RECORD OF DECISION	MARTHA BERRY	BRIAN T. HENNESSEY	CORRESPONDENCE	1
+019649	06/02/20	019649	10693	EPA COMMENTS ON THE 2013 ANNUAL GROUNDWATER MONITORING REPORT (REPORT) FOR THE F AND H AREA RADIOACTIVE LIQUID WASTE TANK FARMS,	MARTHA BERRY	PATRICIA ALLEN	CORRESPONDENCE	3
+019758	08/06/20	WDPD-14-65	10693	DOE SUBMITTAL OF THE U S DEPARTMENT OF ENERGY SIGNED EXPLANATION OF SIGNIFICANT DIFFERENCE ESD FOR INCORPORATING TANKS 5 AND 6 INTO THE REVISION	BRIAN T. HENNESSEY	ROBERT H. POPE SUSAN B. FULMER	CORRESPONDENCE	2
+019759	06/30/20	SRR-CWDA-2014-REV 1	10693	DOE SIGNED EXPLANATION OF SIGNIFICANT DIFFERENCE ESD FOR INCORPORATING TANKS 5 AND 6 INTO THE REVISION 1 INTERIM RECORD OF DECISION	SRR		SUPPORTING DOCUMENT	15
+019786	08/21/20	019786	10693	SCDHEC SUBMITTAL OF THE THREE PARTY SIGNED EXPLANATION OF SIGNIFICANT DIFFERENCE ESD FOR INCORPORATING TANKS 5 AND 6 INTO THE REVISION 1	SUSAN B. FULMER	BRIAN T. HENNESSEY	CORRESPONDENCE	1
+019787	06/30/20	SRR-CWDA-2014-REV 1	10693	THREE PARTY SIGNED EXPLANATION OF SIGNIFICANT DIFFERENCE ESD FOR INCORPORATING TANKS 5 AND 6 INTO THE REVISION 1 INTERIM RECORD DECISION	SRR	243	RECORD OF DECISION	15
+019809	09/11/20	SRR-CWDA-2014-	10693	THE SAVANNAH RIVER SITE ENVIRONMENTAL BULLETIN FOR THE NOTICE OF AVAILABILITY FOR THE EXPLANATION OF SIGNIFICANT DIFFERENCE FOR	SRR	243	COMMUNITY INVOLVEMENT	3
+019817	09/18/20	019817	10693	EPA CONCURRENCE ON THE INTERIM REMEDIAL ACTION COMPLETION FOR F AREA TANK FARM WASTE TANKS 17 THROUGH 20	ARTHUR COLLINS	BRIAN T. HENNESSEY	CORRESPONDENCE	1
+019820	08/14/20	019820	10693	EPA SUBMITTAL OF THE EXPLANATION OF SIGNIFICANT DIFFERENCE ESD FOR INCORPORATING TANKS 5 AND 6 INTO THE REVISION 1 INTERIM RECORD OF DECISION	MARTHA BERRY	SUSAN B. FULMER	CORRESPONDENCE	2
+019822	09/17/20	WDPD-14-15	10693	DOE SUBMITTAL OF THE THREE PARTY SIGNED EXPLANATION OF SIGNIFICANT DIFFERENCE ESD FOR INCORPORATING TANKS 5 AND 6 INTO THE REVISION 1	BRIAN T. HENNESSEY	ROBERT H. POPE SUSAN B. FULMER	CORRESPONDENCE	2
+019881	11/06/20	019881	10693	SCDHEC SUBMITTAL OF SAVANNAH RIVER SITE - SC1 890 008 989 FINAL PERMIT DECISION FOR F AREA TANK FARM WASTE TANKS 5 AND 6	DAVID M SCATURO	KEVIN M KOSTELNIK	CORRESPONDENCE	8
+019948	09/09/20	019948	10693	SCDHEC APPROVAL RE: SAVANNAH RIVER SITE INDUSTRIAL TANKS 5 AND 6 FINAL CONFIGURATION REPORT FOR F TANK FARM SRR-CWDA-2014-00020	JEFFREY P DEBESSONET	VICTOR FRANKLIN	CORRESPONDENCE	1
+019949	05/01/20	019949	10693	EPA COMMENTS ON THE TANKS 5 AND 6 FINAL CONFIGURATION REPORT FCR FOR F TANK FARM AT THE SAVANNAH RIVER SITE SRR-CWDA-2014-00020 REVISION	MARTH BERRY	JOEL CANTRELL	CORRESPONDENCE	3

ARF Index 283

Catalog Num	Date	Doc Number	Track #	Title	Author	Addressee	Doc Type	#of Pages
+019950	05/10/20	SRR-CWDA-2014-	10693	REQUEST TO REMOVE TANKS 241-905F AND 241-906F FROM CONSTRUCTION PERMIT No. 17, 424-IW: F AND H AREA HIGH LEVEL RADIOACTIVE WASTE TANK FARMS	SRR	JOSH YON	CORRESPONDENCE	3
+019951	04/03/20	SRR-CWDA-2014-	10693	TRANSMITTAL OF THE TANKS 5 AND 6 FINAL CONFIGURATION REPORT FOR F TANK FARM AT THE SAVANNAH RIVER SITE SRR-CWDA-2014-00020 REVISION	SRR		CORRESPONDENCE	2
+019952	03/30/20	SRR-CWDA-2014- REV. A	10693	TANKS 5 AND 6 FINAL CONFIGURATION REPORT FOR F TANK FARM AT THE SAVANNAH RIVER SITE SRR-CWDA-2014-00020 REVISION A MARCH 2014	SRR		SUPPORTING DOCUMENT	27
+019967	07/28/20	019967	10693	TRANSMITTAL OF THE TANKS 5 AND 6 FINAL CONFIGURATION REPORT FOR F TANK FARM AT THE SAVANNAH RIVER SITE SRR-CWDA-2014-00020 REVISION	VICTOR A. FRANKLIN	JEFFREY P deBESSONET	CORRESPONDENCE	2
+019968	07/28/20	SRR-CWDA-2014- REV 1	10693	TANKS 5 AND 6 FINAL CONFIGURATION REPORT FOR F TANK FARM AT THE SAVANNAH RIVER SITE - COMMENT RESPONSE	SRR		SUPPORTING DOCUMENT	6
+019969	07/28/20	SRR-CWDA-2014- REV 0	10693	TANKS 5 AND 6 FINAL CONFIGURATION REPORT FOR F TANK FARM AT THE SAVANNAH RIVER SITE JULY 2014 SRR-CWDA-2014-00020 REVISION 0	SRR		SUPPORTING DOCUMENT	26
+019992	12/18/20	019992	10693	SCDHEC APPROVAL RE: REQUEST TO REMOVE TANKS 241-905F AND 241-906F FROM CONSTRUCTION PERMIT No. 17, 424-IW: F AND H AREA HIGH LEVEL RADIOACTIVE	JOSHUA C. YON	VICTOR A FRANKLIN	CORRESPONDENCE	1
+019993	12/19/20	019993	10693	SCDHEC APPROVAL RE: (1) LETTER VICTOR A FRANKLIN SRR TO JOSH YON SCDHEC REQUEST TO REMOVE TANKS 241-905F AND 241-906F FROM CONSTRUCTION	JEFFREY P. deBESSONET	VICTOR A. FRANKLIN	CORRESPONDENCE	2
+020035	02/10/20	020035	10693	STATEMENT OF PARTIAL RESOLUTION OF DISPUTE CONCERNING EXTENSION OF FEDERAL FACILITY AGREEMENT FFA CLOSURE DATE	DISPUTE RESOLUTION COMMITTEE		CORRESPONDENCE	1
+020062	03/03/20	WDPD-15-33	10693	DOE SUBMITTAL OF THE CALENDAR YEAR CY 2014 ANNUAL REPORT STATUS OF F/H AREA RADIOACTIVE LIQUID WASTE TANKS BEING REMOVED FROM SERVICE	BRIAN T. HENNESSEY	ROBERT H. POPE	CORRESPONDENCE	2
+020063	03/03/20	WDPD-15-32	10693	DOE SUBMITTAL OF THE CALENDAR YEAR CY 2014 ANNUAL REPORT STATUS OF F/H AREA RADIOACTIVE LIQUID WASTE TANKS BEING REMOVED FROM SERVICE	BRIAN T. HENNESSEY	SUSAN B. FULMER	CORRESPONDENCE	2
+020064	03/30/20	SRR-ESH-2015-00 Rev 0	10693	CY2014 ANNUAL REPORT STATUS OF F/H AREA RADIOACTIVE LIQUID WASTE TANKS BEING REMOVED FROM SERVICE SRR-ESH-2015-00009 MARCH 2015	SRR		SUPPORTING DOCUMENT	28
+020108	04/16/20	020108	10693	SCDHEC CONCURRENCE OF THE CALENDAR YEAR CY 2014 ANNUAL REPORT STATUS OF F/H AREA RADIOACTIVE LIQUID WASTE TANKS BEING REMOVED	SUSAN B. FULMER	BRIAN T. HENNESSEY	CORRESPONDENCE	1
+020109	04/08/20	020109	10693	STATEMENT CONCERNING RESOLUTION OF DISPUTE FOR EXTENSION OF FEDERAL FACILITY AGREEMENT FFA CLOSURE DATE	SENIOR EXECUTIVE COMMITTEE		CORRESPONDENCE	1
+020177	04/27/20	020177	10693	STATEMENT OF RESOLUTION OF DISPUTE CONCERNING EXTENSION OF FEDERAL FACILITY AGREEMENT FFA CLOSURE DATE	SENIOR EXECUTIVE COMMITTEE		CORRESPONDENCE	2

ARF Index 283

Catalog Num	Date	Doc Number	Track #	Title	Author	Addressee	Doc Type	#of Pages
+020178	04/27/20	WDPD-15-39	10693	DOE SUBMITTAL OF THE NOTIFICATION OF THE INTERIM REMEDIAL ACTION COMPLETION FOR F AREA TANK FARM WASTE TANKS 5 AND 6 CERCLIS NUMBER 23	BRIAN T. HENNESSEY	ROBERT H. POPE SUSAN B. FULMER	CORRESPONDENCE	2
+020238	03/31/20	SRR-ESH-2015-00	10693	2014 ANNUAL GROUNDWATER MONITORING REPORT FOR THE F AND H AREA RADIOACTIVE LIQUID WASTE TANK FARMS (U)	PATRICIAL M. ALLEN	SUSAN B. FULMER	CORRESPONDENCE	3
+020239	03/30/20	SRNS-RP-2015-00 REV 0	10693	2014 ANNUAL GROUNDWATER MONITORING REPORT FOR THE F AND H AREA RADIOACTIVE LIQUID WASTE TANK FORMS (U) CERCLIS NUMBER 23 AND 89	SRNS		SUPPORTING DOCUMENT	68
+020243	05/15/20	020243	10693	SCDHEC COMMENTS ON THE 2014 ANNUAL GROUNDWATER MONITORING REPORT FOR THE F AND H AREA RADIOACTIVE LIQUID WASTE TANK FARMS U	SUSAN B. FULMER	BRIAN T. HENNESSEY	CORRESPONDENCE	2
+020249	05/19/20	IACD-15-147	10693	DOE SUBMITTAL OF THE FEDERAL FACILITY AGREEMENT FFA MINOR MODIFICATION TO INCORPORATE STATEMENTS OF DISPUTE RESOLUTION CONCERNING	BRIAN T. HENNESSEY	ROBERT H. POPE SUSAN B. FULMER	CORRESPONDENCE	6
+020259	05/21/20	020259	10693	SCDHEC TRANSMITTAL OF THE SIGNED FEDERAL FACILITY AGREEMENT FFA MINOR MODIFICATION TO INCORPORATE STATEMENTS OF DISPUTE RESOLUTION	SUSAN B. FULMER	ROBERT H. POPE	CORRESPONDENCE	5
+020261	05/19/20	020261	10693	EPA COMMENTS ON THE 2014 ANNUAL GROUNDWATER MONITORING REPORT FOR THE F AND H AREA RADIOACTIVE LIQUID WASTE TANK FARMS U	MARTHA BERRY	BRIAN T. HENNESSEY	CORRESPONDENCE	2
+020293	04/28/20	020293	10693	EPA CONCURRENCE FOR THE INTERIM REMEDIAL ACTION COMPLETION FOR F AREA TANK FARM WASTE TANKS 5F AND 6F CERCLIS NUMBER 23	DON RIGGER	BRIAN T. HENNESSEY	CORRESPONDENCE	2
+020297	06/08/20	020297	10693	EPA SUBMITTAL OF THE SIGNED FEDERAL FACILITY AGREEMENT FFA MINOR MODIFICATION TO INCORPORATE STATEMENTS OF DISPUTE RESOLUTION	BRIAN T. HENNESSEY	ROBERT H. POPE SUSAN B. FULMER	SUPPORTING DOCUMENT	4
+020520	02/18/20	WDPD-16-20	10693	DOE SUBMITTAL OF THE CALENDAR YEAR 2016 NEED FOR CONTINUED USAGE OF HIGH LEVEL WASTE TANKS POST COMPLETION OF BULK WASTE REMOVAL EFFORTS	BRIAN T. HENNESSEY	ROBERT H. POPE SUSAN B. FULMER	CORRESPONDENCE	3
+020522	11/04/20	SRR-LWP-2015-00	10693	WASTE TREATMENT PLANNING REUSE OF TANK PREVIOUSLY DECLARED BWRE COMPLETE	SRR		SUPPORTING DOCUMENT	12
+020523	12/09/20	SRR-LWP-2015-00	10693	CY2016 WASTE TANK TREATMENT PLANNING	SRR		SUPPORTING DOCUMENT	2
+020530	02/25/20	WDPD-16-26	10693	DOE SUBMITTAL OF THE CALENDAR YEAR CY 2015 ANNUAL REPORT STATUS OF F/H AREA RADIOACTIVE LIQUID WASTE TANKS BEING REMOVED FROM SERVICE	BRIAN T. HENNESSEY	ROBERT H. POPE SUSAN B. FULMER	CORRESPONDENCE	2
+020531	03/30/20	SRR-ESH-2016-00	10693	CY2015 ANNUAL REPORT STATUS OF F/H AREA RADIOACTIVE LIQUID WASTE TANKS BEING REMOVED FROM SERVICE	SRR		SUPPORTING DOCUMENT	97
+020532	02/25/20	020532	10693	EPA APPROVAL OF THE CALENDAR YEAR 2016 NEED FOR CONTINUED USAGE OF HIGH LEVEL WASTE TANKS POST COMPLETION OF BULK WASTE REMOVAL EFFORTS:	JON RICHARDS	BRIAN T. HENNESSEY	CORRESPONDENCE	1

ARF Index 283

Catalog Num	Date	Doc Number	Track #	Title	Author	Addressee	Doc Type	#of Pages
+020701	03/30/20	SRNS-RP-2016-0C REV 0	10693	2015 ANNUAL GROUNDWATER MONITORING REPORT FOR THE F AND H AREA RADIOACTIVE LIQUID WASTE TANK FARMS U CERCLIS NUMBER 23 & 89	SRNS		SUPPORTING DOCUMENT	73
+020704	05/11/20	020704	10693	SCDHEC COMMENTS ON THE 2015 ANNUAL GROUNDWATER MONITORING FOR THE F AND H AREA RADIOACTIVE LIQUID WASTE TANK FARMS U CERCLIS	SUSAN B. FULMER	BRIAN T. HENNESSEY	CORRESPONDENCE	2
+020791	08/08/20	WDPD-16-57	10693	DOE SUBMITTAL OF THE REQUEST FOR MINOR MODIFICATION CONCERNING BULK WASTE REMOVAL EFFORTS APPLICABILITY CERCLIS NUMBERS 23 AND 89	BRIAN T. HENNESSEY	ROBERT H. POPE SUSAN B. FULMER	CORRESPONDENCE	13
+020801	04/04/20	020801	10693	MONITORING OF CLOSED WASTE TANKS FOR H-AREA TANK FARM AND F-AREA TANK FARM (2016) WORK ORDER NUMBER 01482179 01	SRNS		SUPPORTING DOCUMENT	38
+020802	04/14/20	020802	10693	MONITORING OF CLOSED WASTE TANKS FOR F-AREA TANK FARM (2014) WORKING ORDER NUMBER 01309306 01	SRNS		SUPPORTING DOCUMENT	35
+020803	06/07/20	020803	10693	MONITORING OF CLOSED WASTE TANKS FOR F-AREA TANK FARM (2013) WORKING ORDER NUMBER 01288365 01	SRNS		SUPPORTING DOCUMENT	28
+020804	03/31/20	020804	10693	MONITORING OF CLOSED WASTE TANKS FOR H-AREA TANK FARM AND F-AREA TANK FARM (2015) WORK ORDER NUMBER 01403045 01	SRNS		SUPPORTING DOCUMENT	
+020984	02/01/20	SRR-CWDA-2017- REV 0	10693	CONSOLIDATED GENERAL CLOSURE PLAN FOR F-AREA AND H-AREA WASTE TANK SYSTEMS (SRR-CWDA-2017-00015, REV. 0)	SRR		SUPPORTING DOCUMENT	127
+020985	02/27/20	SRNS-J2000-2017	10693	READING ROOM CONSOLIDATED GENERAL CLOSURE PLAN FOR F-AREA AND H-AREA WASTE TANK SYSTEMS (SRR-CWDA-2017-00015, REV. 0)	SRR	USC-AIKEN,USC	CORRESPONDENCE	172
+020986	03/01/20	020986	10693	THE SAVANNAH RIVER SITES ENVIRONMENTAL BULLETIN FOR THE CONSOLIDATED GENERAL CLOSURE PLAN FOR THE F-AREA AND H-AREA WASTE TANK SYSTEMS	SRS		COMMUNITY INVOLVEMENT	2
+020989	03/01/20	WDPD-17-20	10693	DOE SUBMITTAL OF THE CALENDAR YEAR CY 2016 ANNUAL REPORT STATUS OF THE F/H AREA RADIOACTIVE LIQUID WASTE TANKS BEING REMOVED	BRIAN T. HENNESSEY	ROBERT H. POPE SUSAN B. FULMER	CORRESPONDENCE	2
+020990	03/01/20	SRR-ESH-2017-0C	10693	CY2016 ANNUAL REPORT STATUS OF F/H AREA RADIOACTIVE LIQUID WASTE TANKS BEING REMOVED FROM SERVICE SRR-ESH-2017-00009 MARCH 2017	SRR		SUPPORTING DOCUMENT	113
+021011	04/13/20	021011	10693	SCDHEC APPROVAL OF THE CALENDAR YEAR (CY) 2016 ANNUAL REPORT STATUS OF F/H AREA RADIOACTIVE LIQUID WASTE TANKS BEING REMOVED FROM SERVICE,	SUSAN B. FULMER	BRIAN T. HENNESSEY	CORRESPONDENCE	1
+021129	05/01/20	021129	10693	EPA COMMENTS ON THE 2016 GROUNDWATER MONITORING REPORT FOR F-AREA AND H-AREA RADIOACTIVE LIQUID WASTE TANK FARMS	JON RICHARDS	BRIAN T. HENNESSEY	CORRESPONDENCE	2
+021130	03/31/20	SRR-ESH-2017-0C	10693	SRR SUBMITTAL OF THE 2016 ANNUAL GROUNDWATER MONITORING REPORT FOR THE F- AND H- AREA RADIOACTIVE LIQUID WASTE TANK FARMS	PATRICIA M. ALLEN	SUSAN B. FULMER	CORRESPONDENCE	2

ARF Index 283

Catalog Num	Date	Doc Number	Track #	Title	Author	Addressee	Doc Type	#of Pages
+021131	03/30/20	SRNS-RP-2017-00	10693	2016 ANNUAL GROUNDWATER MONITORING REPORT FOR THE F- AND H-AREA RADIOACTIVE LIQUID WASTE TANK FARMS U SRNS-RP-2017-00073, REVISION 0, MARCH	SRNS		SUPPORTING DOCUMENT	83
+021154	05/12/20	021154	10693	SCDHEC APPROVAL OF THE 2016 ANNUAL GROUNDWATER MONITORING REPORT FOR THE F- AND H-AREA RADIOACTIVE LIQUID WASTE TANK FARMS,	SUSAN B. FULMER	BRIAN T. HENNESSEY	CORRESPONDENCE	1
+021187	05/22/20	SRR-OS-2017-000	10693	SCDHEC APPROVAL OF THE CONSOLIDATED GENERAL CLOSURE PLAN FOR F AREA AND H AREA WASTE TANK SYSTEMS, SRR-CWDA-2017-00015, REVISION 1 APRIL 2017	JEFFREY P. DeBESSONET	J. KENT FORTENBERRY	CORRESPONDENCE	2
+021194	04/25/20	SRR-CWDA-2017-	10693	CONSOLIDATED GENERAL CLOSURE PLAN FOR F AREA AND H AREA WASTE TANK SYSTEMS	SRR		CORRESPONDENCE	2
+021195	04/01/20	SRR-CWDA-2017- REV 1	10693	SRR-CWDA-2017-00015 REVISION 1 APRIL 2017 CONSOLIDATED GENERAL CLOSURE PLAN FOR F AREA AND H AREA WASTE TANK SYSTEMS APRIL 2017	SRR		CORRESPONDENCE	129
+021196	04/12/20	SRR-CWDA-2017-	10693	COMMENT RESPONSE MATRIX FOR SCDHEC COMMENTS ON SAVANNAH RIVER REMEDIATION SRR CONSOLIDATED GENERAL CLOSURE PLAN FOR F AREA AND H AREA	SRR		SUPPORTING DOCUMENT	7
+021257	10/02/20	021257	10693	EPA APPROVAL OF THE EXTENSION REQUEST FOR 9/30/17 - HIGH LEVEL WASTE TANKS BULK WASTE REMOVAL EFFORTS BWRE AND OPERATIONAL CLOSURE	JON RICHARDS	BRIAN T. HENNESSEY	CORRESPONDENCE	1
+021258	09/27/20	WDPD-17-46	10693	DOE SUBMITTAL OF THE EXTENSION REQUEST FOR 9/30/17 - HIGH LEVEL WASTE TANKS BULK WASTE REMOVAL EFFORTS BWRE AND OPERATIONAL CLOSURE	BRIAN T. HENNESSEY	ROBERT H. POPE SUSAN B. FULMER	CORRESPONDENCE	2
+021271	10/02/20	021271	10693	SCDHEC APPROVAL OF THE EXTENSION REQUEST FOR 9/30/17 - HIGH LEVEL WASTE TANKS BULK WASTE REMOVAL EFFORTS BWRE AND OPERATIONAL CLOSURE	SUSAN B. FULMER	BRIAN T. HENNESSEY	CORRESPONDENCE	1
+021303	11/16/20	WDPD-18-05	10693	DOE SUBMITTAL OF THREE-PARTY SIGNED SUSPENSION AGREEMENT AND THREE-PARTY SIGNED MINOR MODIFICATION FOR THE HIGH LEVEL WASTE TANKS BULK	BRIAN T. HENNESSEY	JON RICHARDS SUSAN B. FULMER	CORRESPONDENCE	54
+021423	03/01/20	WDPD-18-14	10693	DOE SUBMITTAL OF THE CALENDAR YEAR CY 2017 ANNUAL REPORT STATUS OF F/H AREA RADIOACTIVE LIQUID WASTE TANKS BEING REMOVED FROM SERVICE	BRIAN T.HENNESSEY	JON RICHARDS SUSAN B.	CORRESPONDENCE	2
+021424	03/01/20	SRR-ESH-2018-00	10693	CALENDAR YEAR CY 2017 ANNUAL REPORT STATUS OF F/H AREA RADIOACTIVE LIQUID WASTE TANKS BEING REMOVED FROM SERVICE SRR-ESH-2018-00007 MARCH	SRR		SUPPORTING DOCUMENT	76
+021463	04/09/20	SRR-OS-2018-000	10693	SCDHEC APPROVAL OF THE CONTINUED USAGE OF HIGH LEVEL WASTE TANK 7F, SEMS NUMBER: 23 DATED APRIL 3 2018 AND RECEIVED APRIL 5 2018	SUSAN B. FULMER	BRIAN T. HENNESSEY	CORRESPONDENCE	1
+021468	04/03/20	WDPD-18-21	10693	DOE SUBMITTAL OF THE CONTINUED USAGE OF HIGH-LEVEL WASTE TANK 7F, SEMS NUMBER: 23	BRIAN T. HENNESSEY	JON RICHARDS SUSAN B.	CORRESPONDENCE	6
+021480	04/13/20	021480	10693	SCDHEC APPROVAL OF THE CALENDAR YEAR (CY) 2017 ANNUAL REPORT STATUS OF F/H AREA RADIOACTIVE LIQUID WASTE TANKS BEING REMOVED FROM SERVICE,	S. Fulmer	B. Hennessey	CORRESPONDENCE	1

ARF Index 283

Catalog Num	Date	Doc Number	Track #	Title	Author	Addressee	Doc Type	#of Pages
+021485	04/25/20	SRR-OS-2018-000	10693	EPA APPROVAL OF THE CONTINUED USE OF HIGH-LEVEL WASTE TANK 7F, SEMS NUMBER: 23 (APRIL 3, 2018)	J. Richards	B. Hennessey	CORRESPONDENCE	1
+021629	05/04/20	021629	10693	SCDHEC COMMENTS ON THE 2017 ANNUAL GROUNDWATER MONITORING REPORT FOR THE F-AREA AND H-AREA READIOACTIVE LIQUID WASTE TANK FARMS	S. Fulmer	P. Allen	CORRESPONDENCE	2
+021632	05/17/20	WDPD-18-29	10693	DOE SUBMITTAL LETTER FOR CONTINUED USAGE OF HIGH-LEVEL WASTE TANK 8F, SEMS NUMBER: 23	B. Hennessey	S. Fulmer J. Richards	CORRESPONDENCE	5
+021641	03/22/20	SRR-ESH-2018-00	10693	SRR SUBMITTAL OF 2017 ANNUAL GROUNDWATER MONITORING REPORT FOR THE F- AND H- AREA RADIOACTIVE LIQUID WASTE TANK FARMS (U)	P. Allen	S. Fulmer	CORRESPONDENCE	2
+021645	05/18/20	021645	10693	EPA COMMENTS ON THE 2017 ANNUAL GROUNDWATER MONITORING REPORT FOR THE F- AND H- AREA RADIOACTIVE LIQUID WASTE TANK FARMS, CERCLIS	J. Richards	B. Hennessey	CORRESPONDENCE	2
+021646	05/22/20	021646	10693	EPA APPROVAL OF THE CONTINUED USAGE OF HIGH-LEVEL WASTE TANK 8F, SEMS NUMBER :23 (DATED MAY 17, 2018)	J. Richards	B. Hennessey	CORRESPONDENCE	1
+021659	05/30/20	021659	10693	SCDHEC APPROVAL OF THE CONTINUED USAGE OF HIGH-LEVEL WASTE TANK 8F, SEMS NUMBER: 23 (DATED MAY 17, 2018, AND RECEIVED MAY 21, 2018)	S. Fulmer	B. Hennessey	CORRESPONDENCE	1
+021921	02/01/20	WDPD-19-15	10693	DOE SUBMITTAL OF LIQUID WASTE SYSTEM PLAN REVISION 21 (SEMS NUMBERS: 23 AND 89)	B. HENNESSEY	J. RICHARDS,S. FULMER	CORRESPONDENCE	2
+021922	01/01/20	SRR-LWP-2009-00	10693	SRR LIQUID WASTE SYSTEM PLAN, SRR-LWP-2009-00001, REVISION 21, JANUARY 2019	SRR		SUPPORTING DOCUMENT	62
+021970	03/07/20	WDPD-19-21	10693	DOE SUBMITTAL FOR THE CALENDAR YEAR (CY) 2018 ANNUAL REPORT STATUS OF F/H AREA RADIOACTIVE LIQUID WASTE TANKS BEING REMOVED FROM SERVICE	B. HENNESSEY	J. RICHARDS,S. FULMER	CORRESPONDENCE	2
+021971	03/01/20	SRR-ESH-2019-00	10693	STATUS OF F/H AREA RADIOACTIVE LIQUID WASTE TANKS BEING REMOVED FROM SERVICE CY2018 ANNUAL REPORT (SRR-ESH-2019-00014, REVISION 0, MARCH 2019)	SRR		SUPPORTING DOCUMENT	116
+022010	04/09/20	WDPD-19-27	10693	DOE SUBMITTAL LETTER OF MINOR MODIFICATION FOR THE 2019 SUSPENSION AGREEMENT OF FEDERAL FACILITY AGREEMENT HIGH-LEVEL WASTE TANK	B. HENNESSEY	J. RICHARDS,S. FULMER	CORRESPONDENCE	6
+022147	04/25/20	SRNS-OS-2019-00	10693	EPA APPROVAL AND SIGNATURE FOR THE MINOR MODIFICATION FOR THE 2019 SUSPENSION AGREEMENT OF FFA HIGH-LEVEL WASTE TANK MILESTONES (SEMS 23	J.RICHARDS	B.HENNESSEY	CORRESPONDENCE	5
+022148	04/11/20	SRNS-OS-2019-00	10693	SCDHEC LETTER FOR SIGNATURE MINOR MODIFICATION FOR THE 2019 SUSPENSION AGREEMENT OF FEDERAL FACILITY AGREEMENT HIGH-LEVEL WASTE TANK	S.FULMER	J.RICHARDS	CORRESPONDENCE	1
+022170	03/29/20	SRR-ESH-2019-00	10693	SRR SUBMITTAL OF THE 2018 ANNUAL GROUNDWATER MONITORING REPORT FOR THE F- AND H-AREA RADIOACTIVE LIQUID WASTE TANK FARMS (U)	P. ALLEN	S. FULMER	CORRESPONDENCE	2

ARF Index 283

Catalog Num	Date	Doc Number	Track #	Title	Author	Addressee	Doc Type	#of Pages
022171	03/01/20	SRNS-RP-2019-0C	10693	2018 ANNUAL GROUNDWATER MONITORING REPORT FOR THE F- AND H-AREA RADIOACTIVE LIQUID WASTE TANK FARMS (U) (SRNS-RP-2019-00097, REVISION 0,	SRNS		SUPPORTING DOCUMENT	76
022197	05/09/20	SRNS-OS-2019-0C	10693	SCDHEC COMMENTS ON THE 2018 ANNUAL GROUNDWATER MONITORING REPORT FOR THE F-AREA AND H-AREA RADIOACTIVE LIQUID WASTE TANK FARMS	S. FULMER	P. ALLEN	CORRESPONDENCE	2
022352	09/30/20	IACD-19-147	10693	U.S. DOE SUBMITTAL OF CONTINUED USAGE OF HIGH-LEVEL WASTE TANK 4F, SEMS NUMBER: 23	B. HENNESSEY	J. RICHARDS,S. FULMER	CORRESPONDENCE	5
022368	10/02/20	SRNS-OS-2019-0C	10693	SCDHEC APPROVAL OF CONTINUED USAGE OF HIGH-LEVEL WASTE TANK 4F, SEMS NUMBER: 23 (DATED SEPTEMBER 30, 2019, AND OCTOBER 1, 2019)	S. FULMER	B. HENNESSEY	CORRESPONDENCE	1
022405	09/26/20	WDPD-19-48	10693	DOE SUBMITTAL OF THE DISPUTE RESOLUTION AGREEMENT SUPPLEMENTAL TANK CLOSURE ACTIVITY (STCA): EVALUATION OF THE TECHNICAL FEASIBILITY	J. FOLK	M. LINDLER	CORRESPONDENCE	20
022407	11/04/20	SRNS-OS-2019-0C	10693	EPA COMMENTS ON THE DISPUTE RESOLUTION AGREEMENT SUPPLEMENTAL TANK CLOSURE ACTIVITY [STCA]; EVALUATION OF THE TECHNICAL FEASIBILITY &	J. RICHARDS	B. HENNESSEY	CORRESPONDENCE	3
022616	03/06/20	WDPD-20-19	10693	DOE SUBMITTAL FOR THE CALENDAR YEAR (CY) 2019 ANNUAL REPORT STATUS OF F/H AREA RADIOACTIVE LIQUID WASTE TANKS BEING REMOVED FROM SERVICE	B. HENNESSEY	S. FULMER,J. RICHARDS	CORRESPONDENCE	2
022617	03/01/20	SRR-ESH-2020-0C	10693	STATUS OF F/H AREA RADIOACTIVE LIQUID WASTE TANKS BEING REMOVED FROM SERVICE CY2019 ANNUAL REPORT SRR-ESH-2020-00010 REVISION 0	SRR		SUPPORTING DOCUMENT	74
022677	04/20/20	SRNS-OS-2020-0C	10693	SCDHEC APPROVAL OF THE CALENDAR YEAR (CY) 2019 ANNUAL REPORT STATUS OF F/H AREA RADIOACTIVE LIQUID WASTE TANKS BEING REMOVED FROM SERVICE,	B. HENNESSEY	S. FULMER	CORRESPONDENCE	1
022688	03/23/20	SRR-ESH-2020-0C	10693	SRR SUBMITTAL FOR THE 2019 ANNUAL GROUNDWATER MONITORING REPORT FOR THE F- AND H-AREA RADIOACTIVE LIQUID WASTE TANK FARMS	SRR		CORRESPONDENCE	2
022689	03/17/20	SRNS-RP-2020-0C	10693	2019 ANNUAL GROUNDWATER MONITORING REPORT FOR THE F- AND H-AREA RADIOACTIVE LIQUID WASTE TANK FARMS (SRNS-RP-2020-00066, REVISION 0, MARCH	SRNS		SUPPORTING DOCUMENT	75
022691	05/05/20	SRNS-OS-2020-0C	10693	SCDHEC APPROVAL OF THE 2019 ANNUAL GROUNDWATER MONITORING REPORT FOR THE F- AND H-AREA RADIOACTIVE LIQUID WASTE TANK FARMS (U),	S. FULMER	B. HENNESSEY	CORRESPONDENCE	1
022756	06/17/20	WDPD-20-31	10693	DOE SUBMITTAL LETTER FOR COMPLETION OF FEDERAL FACILITY AGREEMENT MILESTONE "F-TANK FARM (FTF) DEACTIVATION PLAN" LOCATED IN THE 2019	B. HENNESSEY	J. RICHARDS,S. FULMER	CORRESPONDENCE	2
022757	05/01/20	SRR-CWDA-2020-	10693	SAVANNAH RIVER SITE F-TANK FARM DEACTIVATION PLAN AND CLOSURE STRATEGY (SRR-CWDA-2020-00037, REVISION 1, MAY 2020) SEMS NUMBER: 23	SRR		SUPPORTING DOCUMENT	155
022816	07/28/20	WDPD-20-37	10693	DOE SUBMITTAL FOR THE REQUEST FOR CONCURRENCE TO PROCEED TO SAMPLE AND ANALYSIS PHASE OF THE CLOSURE PROCESS FOR F-AREA DIVERSION BOXES	B. HENNESSEY	J. RICHARDS; S. FULMER	CORRESPONDENCE	2

ARF Index 283

Catalog Num	Date	Doc Number	Track #	Title	Author	Addressee	Doc Type	#of Pages
+022817	07/13/20	SRR-CWDA-2020-	10693	SRR PROPOSAL TO CEASE WASTE REMOVAL ACTIVITIES IN F-AREA DIVERSION BOXES 5 AND 6	SRR		SUPPORTING DOCUMENT	97
+022829	07/29/20	SRNS-OS-2020-0C	10693	SCDHEC CONCURRENCE OF THE REQUEST FOR CONCURRENCE TO PROCEED TO SAMPLE AND ANALYSIS PHASE OF THE CLOSURE PROCESS FOR F-AREA	S. FULMER	B. HENNESSEY	CORRESPONDENCE	1
+022832	07/30/20	SRNS-OS-2020-0C	10693	SCDHEC COMMENTS ON THE SAVANNAH RIVER SITE F-AREA TANK FARM DEACTIVATION PLAN AND CLOSURE STRATEGY (SRR-CWDA-2020-00037, REVISION 1, MAY	S. FULMER	B. HENNESSEY	CORRESPONDENCE	2
+022835	08/11/20	SRNS-OS-2020-0C	10693	EPA CONCURRENCE OF THE REQUEST FOR CONCURRENCE TO PROCEED TO SAMPLE AND ANALYSIS PHASE OF THE CLOSURE PROCESS FOR F AREA	R. POPE	B. HENNESSEY	CORRESPONDENCE	2
+022874	03/01/20	SRNS-RP-2018-0C	10693	2017 ANNUAL GROUNDWATER MONITORING REPORT FOR THE F- AND H- AREA RADIOACTIVE LIQUID WASTE TANK FARMS (U) (SRNS-RP-2018-00226, REVISION 0,	SRNS		SUPPORTING DOCUMENT	78
+023048	01/20/20	SRNS-OS-2021-0C	10693	EPA COMMENTS ON THE REVIEW OF THE INDUSTRIAL WASTEWATER CLOSURE MODULE FOR F-AREA DIVERSION BOXES 5 AND 6 F-AREA TANK FARM,	J. RICHARDS	B. HENNESSEY	CORRESPONDENCE	3
+023113	03/02/20	WDPD-21-25	10693	DOE SUBMITTAL LETTER FOR THE CALENDAR YEAR (CY) 2020 ANNUAL REPORT STATUS OF F/H AREA RADIOACTIVE LIQUID WASTE TANKS BEING REMOVED	B. HENNESSEY	J. RICHARDS; S. FULMER	CORRESPONDENCE	2
+023114	03/01/20	SRR-ESH-2021-0C	10693	CALENDAR YEAR (CY) 2020 ANNUAL REPORT STATUS OF F/H AREA RADIOACTIVE LIQUID WASTE TANKS BEING REMOVED FROM SERVICE (SRR-ESH-2021-00012,	SRR		SUPPORTING DOCUMENT	55
023123	03/03/20	SRR-CWDA-2020-	10693	SRR TRANSMITTAL OF THE INDUSTRIAL WASTEWATER CLOSURE MODULE FOR F-AREA DIVERSION BOXES 5 AND 6 F-AREA TANK FARM, SAVANNAH RIVER SITE	SRR		CORRESPONDENCE	2
023127	03/01/20	SRR-ESH-2021-0C	10693	SRR SUBMITTAL FOR THE 2020 ANNUAL GROUNDWATER MONITORING REPORT FOR THE F- AND H- AREA RADIOACTIVE LIQUID WASTE TANK FARMS	P. ALLEN	S. FULMER	CORRESPONDENCE	82
023128	03/01/20	SRNS-RP-2021-0C	10693	2020 ANNUAL GROUNDWATER MONITORING REPORT FOR THE F- AND H-AREA RADIOACTIVE LIQUID WASTE TANK FARMS (U)	SRNS		SUPPORTING DOCUMENT	80
023132	02/01/20	SRR-CWDA-2020-	10693	INDUSTRIAL WASTEWATER CLOSURE MODULE FOR F-AREA DIVERSION BOXES 5 AND 6 F-AREA TANK FARM, SAVANNAH RIVER SITE	SRR		SUPPORTING DOCUMENT	78
023133	02/22/20	SRR-CWDA-2021-	10693	COMMENT RESPONSE MATRIX FOR COMMENTS ON SAVANNAH RIVER REMEDIATION (SRR) INDUSTRIAL WASTEWATER CLOSURE FOR F-AREA DIVERSIO BOXES 5	J. PAVLETICH		SUPPORTING DOCUMENT	20

ARF Index 580

Catalog Num	Date	Doc Number	Track #	Title	Author	Addressee	Doc Type	#of Pages
000570	06/17/92 12:00:00 AM	000570	10693	USEPA COMMENTS TO SCDHEC ON THE HIGH LEVEL WASTE TANK ASSESSMENT REPORTS, F- AND H-AREA TANK FARMS	J. D. JOHNSTON	M. F. SADLER	CORRESPONDENCE	23
000610	07/07/92 12:00:00 AM	000610	10693	SCDHEC COMMENTS ON THE PHASE I AND II F- AND H-AREAS HIGH-LEVEL RADIOACTIVE WASTE TANK FARMS ASSESSMENT REPORTS	L. E. ARRINGTON	J. V. ODUM	CORRESPONDENCE	16
000637	05/18/89 12:00:00 AM	000637	10693	SAVANNAH RIVER SITE NOTICE OF DETECTION OF A RELEASE FROM A RESOURCE CONSERVATION AND RECOVERY ACT TANK SYSTEM	S. R. WRIGHT	W. W. CULLER	CORRESPONDENCE	7
000638	06/29/89 12:00:00 AM	000638	10693	CHARACTERIZATION OF SOIL FROM SAVANNAH RIVER SITE (SRS) H-AREA HIGH LEVEL RADIOACTIVE WASTE TANK FARM RELEASE	S. R. WRIGHT	W. W. CULLER	ENVIRONMENTAL REPORT	12
000749	10/26/92 01:00:00 AM	ESH-FSS-920764	10693	SRS RESPONSE TO SCDHEC/EPA REVIEW COMMENTS ON F AND H AREA HIGH LEVEL RADIOACTIVE WASTE TANK FARM ASSESSMENT REPORT (U)	W. D. DUNAWAY	L. E. ARRINGTON	CORRESPONDENCE	1
000902	01/25/93 12:00:00 AM	000902	10693	STATE CONSTRUCTION PERMIT #17, 424-IW, FOR THE F AND H AREA HIGH-LEVEL RADIOACTIVE WASTE TANK FARMS	M. F. SADLER	W,D,DUNAWAY	CORRESPONDENCE	5
001021	06/29/93 12:00:00 AM	ESH-FSS-930430	10693	F AND H AREA HIGH LEVEL RADIOACTIVE WASTE TANK INSPECTION REPORT (U) (REF: WSRC-TR-93-166, REV. 0, CATALOG NO. 001012)	W. D. DUNAWAY	C. W. RICHARDSON	CORRESPONDENCE	1
001234	08/01/91 12:00:00 AM	WSRC-RP-93-549, REV. 0	10693	ASSESSMENT REPORT PHASE II FOR THE F AND H AREA HIGH-LEVEL RADIOACTIVE WASTE TANK FARMS (U)	WSRC		SUPPORTING DOCUMENT	176
001414	03/03/93 12:00:00 AM	17,424-IW	10693	PARTIAL PERMIT TO OPERATE THE F AND H AREA HIGH LEVEL RADIOACTIVE WASTE TANK FARMS CONSTRUCTION PERMIT NO.: 17,424-IW	SCDHEC		SUPPORTING DOCUMENT	4
001436	03/15/94 01:00:00 AM	WSRC-RP-93-271	10693	F/H AREA HIGH LEVEL WASTE TANK STATUS REPORT	DOE-SR		SUPPORTING DOCUMENT	12
001437	11/09/93 12:00:00 AM	001437	10693	WASTE REMOVAL PLAN AND SCHEDULE FOR THE HIGH LEVEL WASTE TANK FARMS(U) (SEE CATALOG NUMBER 001439)	A. B. GOULD	L. R. BEDENBAUGH	ENVIRONMENTAL REPORT	2
001438	11/09/93 12:00:00 AM	001438	10693	WASTE REMOVAL PLAN AND SCHEDULE FOR THE HIGH LEVEL WASTE TANK FARMS(U) (SEE CATALOG NUMBER 001439)	A. B. GOULD	V. L. WEEKS	ENVIRONMENTAL REPORT	2
001439	11/09/93 12:00:00 AM	WSRC-RP-93-147 REV. 0	10693	F/H AREA HIGH LEVEL WASTE REMOVAL PLAN & SCHEDULE	DOE-SR		SUPPORTING DOCUMENT	18
001656	09/16/94 12:00:00 AM	001656	10693	DOE EXTENSION REQUEST FOR F & H-AREA HIGH LEVEL WASTE TANKS SOURCE CONTROL OPERABLE UNITS RECORD OF DECISION	T. M. TREGER	J. L. CRANE/K. A. COLLINSWORT	CORRESPONDENCE	2
001756	10/06/94 12:00:00 AM	001756	10693	SCDHEC ACCEPTANCE OF THE DEFERMENT OF THE F- AND H-AREA HIGH LEVEL WASTE TANKS SOURCE CONTROL OPERABLE UNITS RECORDS OF DECISION	K. A. COLLINSWORTH	T. M. TREGER	CORRESPONDENCE	1

ARF Index 580

Catalog Num	Date	Doc Number	Track #	Title	Author	Addressee	Doc Type	#of Pages
001773	10/19/94 12:00:00 AM	001773	10693	PROPOSAL TO DELETE THE FEDERAL FACILITY AGREEMENT FISCAL YEAR 1994 COMMITMENT FOR F- AND H-AREA HIGH LEVEL WASTE TANKS SOURCE	T. M. TREGER	K. A. COLLINSWORT	CORRESPONDENCE	10
001880	05/01/94 12:00:00 AM	WSRC-TR-94-166	10693	ANNUAL RADIOACTIVE WASTE TANK INSPECTION PROGRAM - 1993(U), (WSRC-TR-94-166) DATED MAY 1994	WSRC		SUPPORTING DOCUMENT	68
002093	03/01/95 12:00:00 AM	WSRC-RP-95-299	10693	F/H AREA HIGH LEVEL WASTE TANK STATUS REPORT (WSRC-RP-95-299) DATED MARCH 1995	WSRC		SUPPORTING DOCUMENT	12
002108	06/07/95 12:00:00 AM	ESH-ERG-95-0231	10693	SUBMITTAL LETTER FOR THE 1994 F/H AREA HIGH LEVEL RADIOACTIVE WASTE TANK INSPECTION REPORT SEE CATALOG NUMBER 002092	W. D. DUNAWAY	J. L. CRANE/K. A. COLLINSWORT	CORRESPONDENCE	1
002738	03/06/96 12:00:00 AM	ESH-CGP-96-0134	10693	TRANSMITTAL OF THE AGENDA AND HANDOUTS FOR THE F-AREA AND H-AREA HIGH LEVEL WASTE TANK CLOSURE MEETING OF MARCH 4, 1996	J. W. COOK	C. FROEDE	CORRESPONDENCE	15
003033	05/22/96 12:00:00 AM	003033	10693	USEPA COMMENTS ON THE DOE INTERNAL DRAFT COPY OF THE INDUSTRIAL WASTEWATER CLOSURE PLAN FOR F-AREA AND H-AREA HIGH LEVEL WASTE TANKS	C. R. FROEDE, JR.	B. T. HENNESSEY	CORRESPONDENCE	4
003037	07/01/96 12:00:00 AM	003037	10693	USEPA COMMENTS ON REVISION. 0 INDUSTRIAL WASTEWATER CLOSURE PLAN F-AREA AND H-AREA HIGH LEVEL WASTE TANK SYSTEMS	C. R. FROEDE, JR.	B. T. HENNESSEY	CORRESPONDENCE	2
003093	05/29/96 12:00:00 AM	ESH-CGP-96-0284	10693	SUBMITTAL LETTER FOR THE 1995 F/H AREA HIGH LEVEL RADIOACTIVE WASTE TANK INSPECTION REPORT (U)	W. D. DUNAWAY	M. F. SADLER	CORRESPONDENCE	1
003189	07/23/96 12:00:00 AM	003189	10693	EPA APPROVAL OF THE REVISION.1 INDUSTRIAL WASTEWATER CLOSURE PLAN F- AND H- AREA HIGH LEVEL WASTE TANK SYSTEMS	C. R. FROEDE, JR.	B. T. HENNESSEY	CORRESPONDENCE	1
003336	09/19/96 12:00:00 AM	ESH-CGP-96-0488	10693	SAMPLING OF POC WELLS FOR APPENDIX IX AND CRML AT F/H AREAS	J. W. COOK	C. L. DEVLIN	CORRESPONDENCE	2
003832	04/21/97 12:00:00 AM	ESH-CGP-97-0111	10693	PROPOSED POINT OF COMPLIANCE (POC) WELLS FOR 1997 APPENDIX AND CRML SAMPLING AT F/H AREAS	J. W. COOK	C. L. DEVLIN	CORRESPONDENCE	2
003929	05/30/97 12:00:00 AM	ESH-CGP-97-0171	10693	SUBMITTAL LETTER FOR THE 1996 F/H AREA HIGH LEVEL RADIOACTIVE WASTE TANK INSPECTION REPORT	J. W. COOK	M. F. SADLER	CORRESPONDENCE	1
004172	08/28/97 12:00:00 AM	004172	10693	SCDHEC COMMENTS ON THE REQUEST FOR APPROVAL OF APPENDIX C OF THE SAVANNAH RIVE SITE F- AND H- AREA HIGH LEVEL WASTE (HLW) TANKS SYSTEMS	K. A. COLLINSWORTH	B. T. HENNESSEY	CORRESPONDENCE	2
004300	10/02/97 12:00:00 AM	004300	10693	SCDHEC APPROVAL OF THE REQUEST FOR DELAY OF SUBMITTING THE REVISED WASTE REMOVAL AND CLOSURE SCHEDULE FOR THE SAVANNAH RIVER SITE F-	K. A. COLLINSWORTH	B. T. HENNESSEY	CORRESPONDENCE	1
004525	03/01/97 12:00:00 AM	WSRC-RP-97-75	10693	F/H AREA HIGH LEVEL WASTE TANK STATUS REPORT	WSRC		ENVIRONMENTAL REPORT	30

ARF Index 580

Catalog Num	Date	Doc Number	Track #	Title	Author	Addressee	Doc Type	#of Pages
004688	03/05/98 12:00:00 AM	OD-98-036	10693	ANNUAL TANK ASSESSMENT REPORT AND STATUS REPORT FOR THE SAVANNAH RIVER SITE (SRS) HIGH LEVEL WASTE (HLW) TANK 1) ANNUAL TANK	B. T. HENNESSEY	J. L. CRANE / K. A. COLLINSWORT	CORRESPONDENCE	2
004690	03/01/98 12:00:00 AM	WSRC-RP-98-88	10693	ENCLOSURE #2 OD-98-036 SEE CATALOG #004688 F/H AREA HIGH LEVEL WASTE TANK STATUS REPORT AS REQUIRED BY THE FEDERAL FACILITY AGREEMENT (FFA)	WSRC		ENVIRONMENTAL REPORT	13
004794	04/17/98 12:00:00 AM	ESH-CGP-98-0117	10693	PROPOSED POC (POINT OF COMPLIANCE) WELLS FOR 1998 APPENDIX IX AND CRML SAMPLING AT F/H AREAS	J. W. COOK	C. L. DEVLIN	CORRESPONDENCE	2
004966	06/09/98 12:00:00 AM	ESH-CGP-98-0188	10693	SUBMITTAL OF THE 1997 F/H AREA HIGH LEVEL RADIOACTIVE WASTE TANK INSPECTION REPORT (WSRC-TR-98-0083)	J.W. COOK	M.F. SADLER	CORRESPONDENCE	1
005945	06/11/96 12:00:00 AM	005945	10693	NEWSPAPER ADVERTISEMENT- A JOINT INFORMATIONAL MEETING WITH EPA SCDHEC, & DOE TO DISCUSS THE CLOSURE PLAN AND ENVIRONMENTAL ASSESSMENT OF	WSRC		COMMUNITY INVOLVEMENT	17
006031	01/19/99 12:00:00 AM	006031	10693	NEWSPAPER ADVERTISEMENT - FUTURE CLOSURES OF HIGH-LEVEL WASTE (HLW) TANKS AT THE SAVANNAH RIVER SITE	WSRC		COMMUNITY INVOLVEMENT	1
✓008849	06/18/20 11	VOLUME 13, No. 11	10693	ENVIRONMENTAL BULLETIN - VOLUME 13, NUMBER 11 - DOE ANNOUNCES AVAILABILITY OF FINAL EIS ON SRS HIGH-LEVEL WASTE TANK CLOSURES, JUNE 18, 2002	WSRC		COMMUNITY INVOLVEMENT	4
➦010360	12/01/20	ERD-EN-2003-012	10693	GENERAL SEPARATIONS AREA WESTERN GROUNDWATER OPERABLE UNIT SCOPING SUMMARY (ERD-EN-2003-0121) DATED DECEMBER 2003	WSRC		SUPPORTING DOCUMENT	11
✓010752	04/08/20	010752	10693	SCDHEC LETTER ON THE TANK CLOSURE SCHEDULE FOR THE SAVANNAH RIVER SITE (SRS) HIGH LEVEL WASTE (HLW) TANK SYSTEMS	C. M. GORMAN	B. T. HENNESSEY	CORRESPONDENCE	1
✓010890	04/28/20	010890	10693	SCDHEC DISAPPROVAL OF THE EXTENSION REQUEST DATED APRIL 19, 2004, FOR OPERATIONAL CLOSURE OF TANKS 19F AND 18F SAVANNAH RIVER SITE (SRS) HIGH	C. M. GORMAN	B. T. HENNESSEY	CORRESPONDENCE	1
✓010895	04/29/20	010895	10693	EPA DISAPPROVAL OF THE EXTENSION REQUEST (LETTER DATED APRIL 19, 2004) FOR THE OPERATIONAL CLOSURE OF HIGH-LEVEL WASTE TANKS 19F AND 18F	DAWN C. TAYLOR	B. T. HENNESSEY	CORRESPONDENCE	1
✓010952	05/18/20	DD-04-070	10693	DOE LETTER ON THE SCHEDULE SUPPORTING FEDERAL FACILITY AGREEMENT (FFA) EXTENSION REQUEST FOR THE OPERATIONAL CLOSURE OF SAVANNAH RIVER SITE	B. T. HENNESSEY	C. M. GORMAN, D. C. TAYLOR	CORRESPONDENCE	8
✓010956	04/21/97	010956	10693	SCDHEC LETTER ON THE INDUSTRIAL WASTEWATER CLOSURE MODULE FOR THE HIGH LEVEL WASTE TANK 17 SYSTEM, REV.0, SRS/F AREA, DATED APRIL 21, 1997	MELINDA G. VICKERS	J. W. COOK	CORRESPONDENCE	2
✓011003	06/08/20	011003	10693	SCHEDULE SUPPORTING EXTENSION REQUEST FOR THE OPERATIONAL CLOSURE OF HIGH LEVEL WASTE (HLW) TANKS 19F AND 18F (LETTER DATED MAY 18, 2004)	DAWN C. TAYLOR	B. T. HENNESSEY	CORRESPONDENCE	1
✓011010	06/04/20	011010	10693	SCHEDULE FOR OPERATIONAL CLOSURE OF TANKS 19F AND 18F (DATED MAY 18, 2004) SAVANNAH RIVER SITE (SRS) HIGH LEVEL WASTE (HLW) TANK SYSTEMS	CHARLES M. GORMAN	B. T. HENNESSEY	CORRESPONDENCE	1

ARF Index 580

Catalog Num	Date	Doc Number	Track #	Title	Author	Addressee	Doc Type	#of Pages
✓011050	06/24/20	DD-04-100	10693	DOE LETTER ON THE ACCELERATED SCHEDULE SUPPORTING FEDERAL FACILITY AGREEMENT (FFA)	B. T. HENNESSEY	C. M. GORMAN,D. C. TAYLOR	CORRESPONDENCE	3
✓011183	03/04/97	011183	10693	EXTENSION REQUEST FOR THE OPERATIONAL CLOSURE LETTER TO M. F. SADLER, SCDHEC FROM J. W. COOK, MANAGER, CERCLA, GEOLOGICAL AND PERMITTING SECTION, EPD, (ESH-CGP-97-0066), DATED MARCH, 1997,	J. W. COOK	M. F. SADLER	CORRESPONDENCE	3
✓011184	01/09/97	011184	10693	LETTER TO M. F. SADLER, SCDHEC FROM J. W. COOK, EPD (ESH-CGP-97-0003) ON THE REVISED CLOSURE MODULE FOR THE SAVANNAH RIVER SITE HIGH-LEVEL	J. W. COOK	M. F. SADLER	CORRESPONDENCE	2
✓011201	07/23/20	DD-04-126	10693	DOE SUBMITTAL OF THE ACCELERATED SCHEDULE FOR OPERATIONAL CLOSURE OF SAVANNAH RIVER SITE (SRS) HIGH LEVEL WASTE (HLW) TANK 19F AND 18F	JEFFREY D. ALLISON	C. M. GORMAN. D. C. TAYLOR	CORRESPONDENCE	9
✓011246	08/06/20	011246	10693	SCDHEC CONDITIONALLY APPROVAL OF THE SCHEDULE FOR OPERATIONAL CLOSURE OF TANKS 19F AND 18F (JULY 23, 2004) SAVANNAH RIVER SITE (SRS) HIGH LEVEL	C. M. GORMAN	B. T. HENNESSEY	CORRESPONDENCE	2
✓011259	08/09/20	011259	10693	EPA CONDITIONALLY APPROVAL OF THE ACCELERATED SCHEDULE FOR OPERATIONAL CLOSURE OF HIGH LEVEL WASTE (HLW) TANK 19F AND 18F SYSTEMS (LETTER	DAWN C. TAYLOR	B. T. HENNESSEY	CORRESPONDENCE	1
✓011380	08/26/20	DC-04-0155	10693	DOE LETTER ON THE ACCELERATED SCHEDULE FOR OPERATIONAL CLOSURE OF SAVANNAH RIVER SITE (SRS) HIGH LEVEL WASTE (HLW) TANK 19F AND 18F	JEFFREY M. ALLISON	C. M. GORMAN,D. C. TAYLOR	CORRESPONDENCE	9
✓011602	10/18/20	011602	10693	EPA COMMENTS ON THE INDUSTRIAL WASTEWATER CLOSURE PLAN FOR F- AND H-AREA HIGH LEVEL WASTE TANK SYSTEM, WSRC-2003-00498, AUGUST 16, 2004	DAWN C. TAYLOR	DOUGLAS E. HINTZE	CORRESPONDENCE	5
✓011682	08/01/20	WSRC-TR-2003-01	10693	SUBMITTAL OF PRELIMINARY DRAFT INDUSTRIAL WASTEWATER CLOSURE PLAN FOR F- AND H-AREA HIGH-LEVEL WASTE TANK SYSTEMS,	WSRC		SUPPORTING DOCUMENT	317
✓011728	10/20/20	011728	10693	SCDHEC LETTER FROM BARRY S. MULLINAX TO JEFF NEWMAN, WSRC/EPD ON THE INITIAL COMMENTS ON PRELIMINARY CLOSURE PLAN FOR THE HIGH LEVEL	BARRY S. MULLINAX	JEFF NEWMAN	CORRESPONDENCE	12
✓011729	10/25/20	011729	10693	SCDHEC LETTER FROM BARRY S. MULLINAX TO JEFF NEWMAN ON THE EPA COMMENTS FOR THE PRELIMINARY INDUSTRIAL WASTEWATER CLOSURE	BARRY S. MULLINAX	JEFF NEWMAN	CORRESPONDENCE	5
✓012210	03/09/20	WDPD-05-120	10693	DOE SUBMITTAL LETTER AND REPORT OF THE ANNUAL TANK STATUS REPORT FOR THE SAVANNAH RIVER SITE (SRS) HIGH LEVEL WASTE (HLW) TANK SYSTEMS	B. T. HENNESSEY	C. M. GORMAN,D. C. TAYLOR	CORRESPONDENCE	57
✓013368	02/02/20	CBU-PIT-2005-002	10693	INDUSTRIAL WASTEWATER CLOSURE MODULE FOR TANK 19 AND TANK 18 SAVANNAH RIVER SITE, CBU-PIT-2005-00287, DATED FEBRUARY 2, 2006	WSRC		SUPPORTING DOCUMENT	131
✓013370	03/23/20	CBU-PIT-2006-000	10693	WSRC TRANSMITTAL OF DRAFT RESPONSES TO COMMENTS ON AUGUST 2004 INDUSTRIAL WASTEWATER CLOSURE PLAN, RSM TRACK #: 10667, DATED MARCH 23,	Steven A. Thomas	Barry Mullinax	CORRESPONDENCE	79
✓013373	04/18/20	WDPD-06-108	10693	DOE SUBMITTAL ON THE EXTENSION REQUEST FOR COMPLETION OF CLOSURE FOR HIGH LEVEL WASTE (HLW) TANK 19 AND TANK 18 AT SAVANNAH RIVER SITE	B. T. Hennessey	D. C. TAYLOR / C. M. GORMAN	CORRESPONDENCE	1

ARF Index 580

Catalog Num	Date	Doc Number	Track #	Title	Author	Addressee	Doc Type	#of Pages
013383	03/09/20	WDPD-06-100	10693	DOE SUBMITTAL FOR THE F/H AREA HIGH LEVEL WASTE (HLW) TANK STATUS REPORT FOR CALENDAR YEAR (CY) 2005 (ESH-EPG-2006-00005, MARCH 2006) FOR THE	Jeffery M. Allison	D. C. TAYLOR / C. M. GORMAN	CORRESPONDENCE	43
013739	07/06/20	013739	10693	DOE LETTER - BODMAN TO SANFORD - TREATMENT AND DISPOSITION OF THE SALT WASTE IN TANKS LOCATED AT SAVANNAH RIVER SITE, DATED JULY 6, 2006	Samuel W. Bodman	Gov. Mark Sanford	CORRESPONDENCE	2
013751	05/12/20	013751	10693	SCDHEC COMMENTS ON THE INDUSTRIAL WASTEWATER CLOSURE MODULE FOR TANK 19 AND TANK 18, REVISION A, SAVANNAH RIVER SITE, INCLUDING EPA REVIEW,	Shelly Sherritt	Virginia G. Dickert	CORRESPONDENCE	14
014347	03/27/20	014347	10693	SCDHEC COMMENTS ON THE NON-CONCURRENCE OF THE EXTENSION REQUEST FOR COMPLETION OF CLOSURE FOR HIGH LEVEL WASTE TANK 19 AND TANK 18	Charles M. Gorman	B. T. HENNESSEY	CORRESPONDENCE	2
014446	03/09/20	WDPD-07-012	10693	DOE SUBMITTAL OF THE CALENDAR YEAR (CY) 2006 STATUS OF F/H AREA RADIOACTIVE LIQUID WASTE TANKS BEING REMOVED FROM SERVICE	BRIAN HENNESSEY	D.C. TAYLOR/D.L. SIRON	CORRESPONDENCE	2
014447	03/01/20	ESH-EPG-2007-00 REV. 1	10693	CY2006 ANNUAL REPORT, STATUS OF F/H AREA RADIOACTIVE LIQUID WASTE TANKS BEING REMOVED FROM SERVICE, ESH-EPG-2007-00016, REVISION 1,	WSRC		SUPPORTING DOCUMENT	71
014587	03/07/95	GB-95-0081	10693	DOE SUBMITTAL ON THE ANNUAL STATUS REPORT FOR THE SAVANNAH RIVER SITE (SRS) HIGH LEVEL WASTE TANKS, (WSRC-RP-95-299, DATED MARCH 1995)	A. B. GOULD	K. A. COLLINSWORT	CORRESPONDENCE	1
014588	03/07/95	GB-95-0082	10693	DOE SUBMITTAL ON THE ANNUAL STATUS REPORT FOR THE SAVANNAH RIVER SITE (SRS) HIGH LEVEL WASTE TANKS, (WSRC-RP-95-299, DATED MARCH 1995)	A. B. GOULD	J. CRANE	CORRESPONDENCE	1
014739	06/12/20	WSRC-TR-2007-00	10693	SRS CY2006 F/H AREA LIQUID WASTE TANK INSPECTION REPORT (WSRC-TR-2007-00094)	RONALD CAMPBELL	JEFFERY DEBESSONET	SUPPORTING DOCUMENT	107
014740	06/07/20	WSRC-TR-2006-00	10693	SRS CY2005 F/H AREA HIGH LIQUID RADIOACTIVE WASTE TANK INSPECTION REPORT (WSRC-TR-2006-00170), DATED JUNE 7, 2006	RONALD M. CAMPBELL	JEFFREY DEBESSONET	SUPPORTING DOCUMENT	128
014848	09/21/20	014848	10693	SCDHEC COMMENTS ON THE SAVANNAH RIVER SITE FEDERAL FACILITY AGREEMENT DISPUTE RESOLUTION REGARDING THE SCHEDULE FOR COMPLETION OF	DONALD SIRON	BRIAN HENNESSEY	CORRESPONDENCE	2
014946	11/02/20	014946	10693	SCDHEC RESPONSE TO US DEPARTMENT OF ENERGY WRITTEN STATEMENT OF DISPUTE FOR USE BY THE DISPUTE RESOLUTION COMMITTEE (DRC) AND UPDATED	DONALD SIRON	B. T. HENNESSEY	CORRESPONDENCE	2
014990	11/29/20	ACP-08-119	10693	DOE SUBMITTAL OF THE SIGNED STATEMENT OF RESOLUTION OF DISPUTE CONCERNING EXTENSION OF CLOSURE DATES FOR SAVANNAH RIVER SITE	BRIAN HENNESSEY	R.H. POPE/D.L. SIRON	CORRESPONDENCE	5
014993	10/22/20	WDPD-08-009	10693	DOE SUBMITTAL OF THE WRITTEN STATEMENT OF DISPUTE SUBMITTED TO THE DISPUTE RESOLUTION COMMITTEE (DRC), (REFERENCE 1, SECTION XXVII.A AND	TERRY J. SPEARS	F. HILL/D.W. CHIEF	CORRESPONDENCE	5
015025	12/20/20	ACP-08-131	10693	DOE SUBMITTAL OF THE FEDERAL FACILITY AGREEMENT (FFA) MODIFICATION TO INCORPORATE STATEMENT OF RESOLUTION OF DISPUTE CONCERNING EXTENSION OF	BRIAN HENNESSEY	R.L. POPE/D.L. SIRON	CORRESPONDENCE	8

ARF Index 580

Catalog Num	Date	Doc Number	Track #	Title	Author	Addressee	Doc Type	#of Pages
✓015574	08/25/20	015574	10693	SCDHEC CORRESPONDENCE ON THE F-AREA AND H-AREA HIGH LEVEL WASTE TANK CLOSURE PLAN AND PERFORMANCE ASSESSMENT SAVANNAH RIVER SITE.	MELISSA J. KING	GENE H. LASKA	CORRESPONDENCE	1
✓015575	08/16/20	015575	10693	WSRC CORRESPONDENCE ON THE SAVANNAH RIVER SITE F-AREA AND H-AREA HIGH LEVEL WASTE TANK CLOSURE PLAN AND PERFORMANCE ASSESSMENT -	GENE H. LASKA	ADRIENNE F. WRIGHT	CORRESPONDENCE	13
✓015722	10/31/20	WDPD-09-005	10693	DOE SUBMITTAL OF THE STATUS OF WASTE REMOVAL ACTIVITIES IN TANKS 18 AND 19	BRIAN HENNESSEY	R.H. POPE/V. KEISLER	CORRESPONDENCE	2
✓015758	11/05/20	015758	10693	SCDHEC COMMENTS ON THE LETTER - HENNESSEY TO KEISLER AND POPE, STATUS OF WASTE REMOVAL ACTIVITIES IN TANK 18 AND 19, DATED OCTOBER 31, 2008	VAN KEISLER	B. T. HENNESSEY	CORRESPONDENCE	2
✓015795	12/23/20	015795	10693	EPA APPROVAL OF THE SAVANNAH RIVER SITE (SRS) EXTENSION REQUEST FOR WASTE REMOVAL ACTIVITIES IN TANK 18 AND 19, DATED DECEMBER 22, 2008	ROBERT POPE	B. T. HENNESSEY	CORRESPONDENCE	2
✓015801	12/22/20	WDPD-09-008	10693	DOE SUBMITTAL OF THE WASTE REMOVAL ACTIVITIES IN TANKS 19 AND 18. REF. (1) LETTER, KEISLER TO HENNESSEY, 11/5/08, (2) LETTER, HENNESSEY TO SIRON	BRIAN HENNESSEY	R.H. POPE/V. KEISLER	CORRESPONDENCE	2
✓015816	01/07/20	015816	10693	SCDHEC APPROVAL OF THE WASTE REMOVAL ACTIVITIES IN TANK 18 AND 19, DATED DECEMBER 22, 2008, REFERENCED IN A SCDHEC LETTER FROM	VAN KEISLER	B. T. HENNESSEY	CORRESPONDENCE	2
✓015818	01/05/20	015818	10693	EPA COMMENTS ON THE PERFORMANCE ASSESSMENT FOR THE F-TANK FARM AT THE SAVANNAH RIVER SITE, REVISION 0, DATED JUNE 27, 2008 (SRS-REG-2007-00002)	MARTHA BERRY	B. T. HENNESSEY	CORRESPONDENCE	17
✓015857	08/20/20	WDPD-08-070	10693	DOE SUBMITTAL OF THE PERFORMANCE ASSESSMENT FOR THE F-TANK FARM AT THE SAVANNAH RIVER SITE, REVISION 0, DATED JUNE 27, 2008	TERRELL J. SPEARS	PATTY DUNBAR	CORRESPONDENCE	2
✓015858	08/20/20	WDPD-08-071	10693	DOE SUBMITTAL OF THE PERFORMANCE ASSESSMENT FOR THE F-TANK FARM AT THE SAVANNAH RIVER SITE, REVISION 0, DATED JUNE 27, 2008	BRIAN HENNESSEY	R.H. POPE/V. KEISLER	CORRESPONDENCE	2
✓015859	06/26/20	SRS-REG-2008-0C	10693	SUBMITTAL OF THE PERFORMANCE ASSESSMENT FOR THE F-TANK FARM AT THE SAVANNA RIVER SITE (THIS IS IN REFERENCE TO: SRS-REG-2007-00002, REVISION 0,	V.G. Dickert	L. D. Olson	CORRESPONDENCE	5
✓015860	08/13/20	SRS-REG-2007-0C	10693	PART I: REVIEW TEAM REPORT FOR THE PERFORMANCE ASSESSMENT FOR THE F-TANK FARM AT THE SAVANNAH RIVER SITE, DATED AUGUST 13, 2008 AND	WSRC		SUPPORTING DOCUMENT	2720
✓015861	06/27/20	SRS-REG-2007-0C	10693	PART II: PERFORMANCE ASSESSMENT FOR THE F-TANK FARM AT THE SAVANNAH RIVER SITE (REDACTED VERSION) SRS-REG-2007-00002 REVISION 0 DATED JUNE	WSRC		SUPPORTING DOCUMENT	6,354
015862	06/27/20	SRS-REG-2007-0C	10693	PART III: PERFORMANCE ASSESSMENT FOR THE F-TANK FARM AT THE SAVANNAH RIVER SITE (REDACTED VERSION) SRS-REG-2007-00002, REVISION 0, DATED JUNE	WSRC		SUPPORTING DOCUMENT	6,308
✓015863	06/27/20	SRS-REG-2007-0C	10693	PART IV: PERFORMANCE ASSESSMENT FOR THE F-TANK FARM AT THE SAVANNAH RIVER SITE (REDACTED VERSION) SRS-REG-2007-00002, REVISION 0, DATED JUNE	WSRC		SUPPORTING DOCUMENT	6,199

ARF Index 580

Catalog Num	Date	Doc Number	Track #	Title	Author	Addressee	Doc Type	#of Pages
✓015864	06/27/20	SRS-REG-2007-0C REV. 0	10693	PART V: PERFORMANCE ASSESSMENT FOR THE F-TANK FARM AT THE SAVANNAH RIVER SITE (REDACTED VERSION) SRS-REG-2007-00002, REVISION 0, DATED JUNE	WSRC		CORRESPONDENCE	6,289
✓015865	06/27/20	SRS-REG-2007-0C REV. 0	10693	PART VI: PERFORMANCE ASSESSMENT FOR THE F-TANK FARM AT THE SAVANNAH RIVER SITE (REDACTED VERSION) SRS-REG-2007-00002, REVISION 0, DATED JUNE	WSRC		SUPPORTING DOCUMENT	2,611
✓015869	10/31/20	015869	10693	SCDHEC COMMENTS ON THE PERFORMANCE ASSESSMENT FOR THE F-TANK FARM AT THE SAVANNAH RIVER SITE, REVISION 0, (DOCUMENT NO.	VAN KEISLER	B. T. HENNESSEY	CORRESPONDENCE	11
✓015911	02/19/20	LWO-CES-2009-0C	10693	SRS TRANSMITTAL OF CY2008 ANNUAL REPORT STATUS OF F/H AREA RADIOACTIVE LIQUID WASTE TANKS BEING REMOVED FROM SERVICE, MARCH 2009	DANIEL P. SKIFF	MICHAEL HUGHES	CORRESPONDENCE	1
✓015912	02/25/20	SRNS-J2000-2009	10693	SRNS TRANSMITTAL OF THE CY2008 ANNUAL REPORT STATUS OF F/H AREA RADIOACTIVE LIQUID WASTE TANKS BEING REMOVED FROM SERVICE, MARCH 2009	JEANNETTE E. HYATT	SHERRI R. ROSS	CORRESPONDENCE	2
✓015913	03/02/20	WDPD-09-022	10693	DOE SUBMITTAL OF THE CALENDAR YEAR (CY) 2008 ANNUAL REPORT STATUS OF F/H AREA RADIOACTIVE LIQUID WASTE TANKS BEING REMOVED FROM SERVICE	BRIAN HENNESSEY	R.H. POPE/V. KEISLER	CORRESPONDENCE	2
✓015914	03/01/20	LWO-CES-2009-0C	10693	CY2008 ANNUAL REPORT STATUS OF F/H AREA RADIOACTIVE LIQUID WASTE TANKS BEING REMOVED FROM SERVICE (LWO-CES-2009-00001, MARCH 2009)	WSRC		SUPPORTING DOCUMENT	74
✓016088	05/21/20	016088	10693	EPA COMMENTS ON THE CY2008 ANNUAL REPORT STATUS OF F/H AREA RADIOACTIVE LIQUID WASTE TANKS BEING REMOVED FROM SERVICE,	MARTHA BERRY	B. T. HENNESSEY	CORRESPONDENCE	4
✓016235	02/26/20	LWO-LWE-2008-0C REV. 1	10693	TANKS 18 AND 19 WASTE DETERMINATION SAMPLE PLAN, T. HUFF/G.D. THAXTON LWO-LWE-2008-00186, REVISION 1, DATED FEBRUARY 2009		J.R. CANTRELL/J.E. HERBERT	SUPPORTING DOCUMENT	13
✓016236	07/24/20	016236	10693	SCDHEC COMMENTS ON TANKS 18 AND 19 WASTE DETERMINATION SAMPLE PLAN, LWO-LWE-2008-00186, REVISION 1, DATED FEBRUARY 26, 2009	VAN KEISLER	B. T. HENNESSEY	CORRESPONDENCE	2
✓016237	07/09/20	016237	10693	EPA COMMENTS ON TANKS 18 AND 19 WASTE DETERMINATION SAMPLE PLAN, LWO-LWE-2008-00186, REVISION 1, DATED FEBRUARY 26, 2009	MARTHA BERRY	VAN KEISLER	CORRESPONDENCE	6
✓016290	08/24/20	WDPD-09-055	10693	DOE SUBMITTAL OF THE RESPONSES TO THE EPA REVIEW OF THE CALENDAR YEAR (CY) 2008 ANNUAL REPORT STATUS OF F/H AREA RADIOACTIVE LIQUID	BRIAN HENNESSEY	R.H. POPE/V. KEISLER	CORRESPONDENCE	10
✓016390	10/23/20	WDPD-10-02	10693	DOE SUBMITTAL OF THE REQUEST FOR CONCURRENCE TO PROCEED TO SAMPLE AND ANALYSIS PHASE OF THE TANK CLOSURE PROCESS FOR TANKS 18 AND 19	BRIAN HENNESSEY	R.H. POPE/V. KEISLER	CORRESPONDENCE	2
✓016391	10/01/20	SRR-CWDA-2009-	10693	PROPOSAL TO CEASE WASTE REMOVAL ACTIVITIES IN TANKS 18 AND 19 AND ENTER SAMPLING AND ANALYSIS PHASE, SRR-CWDA-2009-00030, DATED OCTOBER 1, 2009	SRNS		SUPPORTING DOCUMENT	58
✓016413	11/06/20	016413	10693	EPA APPROVAL OF DOE SUBMITTAL OF THE REQUEST FOR CONCURRENCE TO PROCEED TO SAMPLE AND ANALYSIS PHASE OF THE TANK CLOSURE PROCESS FOR	MARTHA MERRY	B. T. HENNESSEY	CORRESPONDENCE	2

ARF Index 580

Catalog Num	Date	Doc Number	Track #	Title	Author	Addressee	Doc Type	#of Pages
✓016414	11/09/20	016414	10693	SCDHEC APPROVAL OF THE REQUEST FOR CONCURRENCE TO PROCEED TO SAMPLE AND ANALYSIS PHASE OF THE TANK CLOSURE PROCESS FOR TANKS 18	VAN KEISLER	B. T. HENNESSEY	CORRESPONDENCE	1
✓016703	03/08/20	WDPD-10-042	10693	DOE SUBMITTAL OF THE CALENDAR YEAR (CY) 2009 ANNUAL REPORT STATUS OF F/H AREA RADIOACTIVE LIQUID WASTE TANKS BEING REMOVED FROM SERVICE,	BRIAN HENNESSEY	R.H. POPE/V. KEISLER	CORRESPONDENCE	2
✓016704	03/01/20	LWO-CES-2010-00	10693	CY2009 ANNUAL REPORT STATUS OF F/H AREA RADIOACTIVE LIQUID WASTE TANKS BEING REMOVED FROM SERVICE (LWO-CES-2010-00001, MARCH 2010)	SRNS		SUPPORTING DOCUMENT	89
✓016711	02/23/20	SRR-LWE-2010-00	10693	SRR RESPONSES TO SCDHEC AND EPA COMMENTS ON THE TANKS 18 AND 19 WASTE DETERMINATION SAMPLE PLAN, LWO-LWE-2008-00186, REVISION 1, FEBRUARY 26,	WALT ISOM	SHERRI R. ROSS	CORRESPONDENCE	
✓016794	04/15/20	016794	10693	SCDHEC COMMENTS ON THE CY2009 ANNUAL REPORT STATUS OF F/H AREA RADIOACTIVE LIQUID WASTE TANKS BEING REMOVED FROM SERVICE (AS REQUIRED	VAN KEISLER	B. T. HENNESSEY	CORRESPONDENCE	4
✓017057	08/09/20	WDPD-10-074	10693	DOE SUBMITTAL OF THE COMPLETION OF BULK WASTE REMOVAL (BWR) EFFORT IN TANK 8	BRIAN HENNESSEY	R.H. POPE/V. KEISLER	CORRESPONDENCE	20
✓017065	08/30/20	017065	10693	SCDHEC SUBMITTAL OF THE FEDERAL FACILITY AGREEMENT (FFA) MODIFICATION TO INCORPORATE THE ADDENDUM TO THE STATEMENT OF RESOLUTION OF	VAN KEISLER	MARTHA BERRY	CORRESPONDENCE	4
✓017078	08/25/20	ACP-10-253	10693	DOE SUBMITTAL OF THE FEDERAL FACILITY AGREEMENT (FFA) MODIFICATION TO INCORPORATE THE ADDENDUM TO THE STATEMENT OF RESOLUTION OF DISPUTE	BRIAN HENNESSEY	R.H. POPE/V. KEISLER	CORRESPONDENCE	4
✓017094	06/25/20	LWO-CES-2010-00	10693	SRR SUBMITTAL OF THE SAVANNAH RIVER SITE ANNUAL RADIOACTIVE WASTE TANK INSPECTION PROGRAM - 2009 (SRR-STI-2010-00283)	PATRICIA M. ALLEN	R.H. POPE/J.P. DEBESSONET	CORRESPONDENCE	3
✓017095	06/01/20	SRR-STI-2010-002	10693	ANNUAL RADIOACTIVE WASTE TANK INSPECTION PROGRAM - 2009, SRR-STI-2010-000283, DATED JUNE 2010	SRR		SUPPORTING DOCUMENT	112
✓017103	08/31/20	017103	10693	EPA COMMENTS ON THE SRS ANNUAL RADIOACTIVE WASTE TANK INSPECTION PROGRAM - 2009, SRR-STI-2010-000283, DATED JUNE 2010	MARTHA BERRY	B. T. HENNESSEY	CORRESPONDENCE	3
✓017110	08/30/20	017110	10693	EPA SUBMITTAL OF THE FEDERAL FACILITY AGREEMENT (FFA) MODIFICATION TO INCORPORATE THE ADDENDUM TO THE STATEMENT OF RESOLUTION OF DISPUTE	MARTHA BERRY	B. T. HENNESSEY	CORRESPONDENCE	7
✓017113	04/07/20	WDPD-10-050	10693	DOE SUBMITTAL OF THE PERFORMANCE ASSESSMENT FOR THE F-TANK FARM AT THE SAVANNAH RIVER SITE (SRS), (SRS-REG-2007-00002, REVISION 1, DATED MARCH	BRIAN HENNESSEY	R.H. POPE/V. KEISLER	CORRESPONDENCE	3
✓017114	03/31/20	SRS-REG-2007-00	10693	PART I - APPROVED FOR PUBLIC RELEASE - PERFORMANCE ASSESSMENT FOR THE F-TANK FARM AT THE SAVANNAH RIVER SITE, SRS-REG-2007-00002,	SRR		SUPPORTING DOCUMENT	5056
✓017115	03/31/20	SRS-REG-2007-00	10693	PART II - APPROVED FOR PUBLIC RELEASE - REFERENCES FOR THE PERFORMANCE ASSESSMENT FOR THE F-TANK FARM AT THE SAVANNAH RIVER SITE,	SRR		SUPPORTING DOCUMENT	5145

ARF Index 580

Catalog Num	Date	Doc Number	Track #	Title	Author	Addressee	Doc Type	#of Pages
✓017116	03/31/20	SRS-REG-2007-0C REV. 1	10693	PART III - APPROVED FOR PUBLIC RELEASE - REFERENCES FOR THE PERFORMANCE ASSESSMENT FOR THE F-TANK FARM AT THE SAVANNAH RIVER SITE,	SRR		SUPPORTING DOCUMENT	6322
✓017117	03/31/20	SRS-REG-2007-0C REV. 1	10693	PART IV - APPROVED FOR PUBLIC RELEASE - REFERENCES FOR THE PERFORMANCE ASSESSMENT FOR THE F-TANK FARM AT THE SAVANNAH RIVER SITE,	SRR		SUPPORTING DOCUMENT	5217
✓017118	09/07/20	017118	10693	SCDHEC APPROVAL TO CONTINUE USING TANK 8	VAN KEISLER	B. T. HENNESSEY	CORRESPONDENCE	2
✓017119	03/31/20	SRS-REG-2007-0C REV. 1	10693	PART V - APPROVED FOR PUBLIC RELEASE - REFERENCES FOR THE PERFORMANCE ASSESSMENT FOR THE F-TANK FARM AT THE SAVANNAH RIVER SITE,	SRR		SUPPORTING DOCUMENT	5962
✓017120	09/21/20	017120	10693	EPA APPROVAL OF THE COMPLETION OF BULK WASTE REMOVAL (BWR) EFFORTS IN TANK 8	ROBERT POPE	B. T. HENNESSEY	CORRESPONDENCE	2
+017121	03/31/20	SRS-REG-2007-0C REV. 1	10693	PART VI - APPROVED FOR PUBLIC RELEASE - REFERENCES FOR THE PERFORMANCE ASSESSMENT FOR THE F-TANK FARM AT THE SAVANNAH RIVER SITE,	SRR		SUPPORTING DOCUMENT	975
✓017122	06/29/20	017122	10693	SCDHEC COMMENTS ON THE PERFORMANCE ASSESSMENT FOR THE F-TANK FARM AT THE SAVANNAH RIVER SITE (SRS), (SRS-REG-2007-00002, REVISION 1,	VAN KEISLER	B. T. HENNESSEY	CORRESPONDENCE	4
✓017123	06/30/20	017123	10693	EPA COMMENTS ON THE PERFORMANCE ASSESSMENT FOR THE F-TANK FARM AT THE SAVANNAH RIVER SITE, (SRS-REG-2007-00002, REVISION 1, DATED MARCH 31,	MARTHA BERRY	B. T. HENNESSEY	CORRESPONDENCE	7
✓017126	09/17/20	WDPD-10-081	10693	DOE SUBMITTAL OF THE COMPLETION OF BULK WASTE REMOVAL (BWR) EFFORTS IN TANK 12, (SRR-CWDA-2010-00126, REVISION 1, DATED SEPTEMBER	BRIAN HENNESSEY	R.H. POPE/V. KEISLER	CORRESPONDENCE	2
✓017127	09/08/20	SRR-CWDA-2010- REV. 1	10693	COMPLETION OF BULK WASTE REMOVAL (BWR) EFFORTS IN TANK 12, SRR-CWDA-2010-00126, REVISION 1, DATED SEPTEMBER 8, 2010	SRR		SUPPORTING DOCUMENT	18
✓017129	09/23/20	ACP-10-269	10693	DOE SUBMITTAL OF THE THREE-PARTY SIGNED FEDERAL FACILITY AGREEMENT MODIFICATION TO INCORPORATE THE ADDENDUM TO THE STATEMENT OF RESOLUTION OF	BRIAN HENNESSEY	R.H. POPE/V. KEISLER	CORRESPONDENCE	4
✓017167	09/29/20	017167	10693	SCDHEC APPROVAL OF THE COMPLETION OF BULK WASTE REMOVAL (BWR) EFFORTS IN TANK 12, SRR-CWDA-2010-00126, REVISION 1, DATED SEPTEMBER	VAN KEISLER	B. T. HENNESSEY	CORRESPONDENCE	1
✓017196	09/29/20	017196	10693	EPA CONCURRENCE OF COMPLETION OF BULK WASTE REMOVAL (BWR) EFFORTS IN TANK 12	R. H. POPE	B. T. HENNESSEY	CORRESPONDENCE	2
✓017234	11/10/20	WDPD-11-12	10693	DOE REQUEST FOR CONCURRENCE TO PROCEED TO SAMPLE AND ANALYSIS PHASE OF THE TANK CLOSURE PROCESS FOR TANKS 5 AND 6, (SRR-CWDA-2010-00157,	BRIAN HENNESSEY	R.H. POPE/V. KEISLER	CORRESPONDENCE	188
✓017266	11/22/20	017266	10693	SCDHEC APPROVAL OF THE CONCURRENCE TO PROCEED TO SAMPLE AND ANALYSIS PHASE OF THE TANK CLOSURE PROCESS FOR TANKS 5 AND 6, DATED	VAN KEISLER	B. T. HENNESSEY	CORRESPONDENCE	1

ARF Index 580

Catalog Num	Date	Doc Number	Track #	Title	Author	Addressee	Doc Type	#of Pages
✓017273	03/31/20	SRS-REG-2007-0C 10693	1	PART I: OOU VERSION OF THE - PERFORMANCE ASSESSMENT FOR THE F-TANK FARM AT THE SAVANNAH RIVER SITE (REDACTED VERSION) SRS-REG-2007-00002,	SRNS		SUPPORTING DOCUMENT	3125
✓017274	03/31/20	SRS-REG-2007-0C 10693	1	PART II - OOU REFERENCES FOR THE PERFORMANCE ASSESSMENT FOR THE F-TANK FARM AT THE SAVANNAH RIVER SITE (REDACTED VERSION) SRS-REG-2007-00002,	SRNS		SUPPORTING DOCUMENT	755
✓017275	03/31/20	SRS-REG-2007-0C 10693	1	PART III - OOU REFERENCES FOR THE PERFORMANCE ASSESSMENT FOR THE F-TANK FARM AT THE SAVANNAH RIVER SITE (REDACTED VERSION) SRS-REG-2007-00002,	SRNS		SUPPORTING DOCUMENT	1659
✓017276	03/31/20	SRS-REG-2007-0C 10693	1	PART IV - OOU REFERENCES FOR THE PERFORMANCE ASSESSMENT FOR THE F-TANK FARM AT THE SAVANNAH RIVER SITE (REDACTED VERSION) SRS-REG-2007-00002,	SRNS		SUPPORTING DOCUMENT	1469
✓017277	03/31/20	SRS-REG-2007-0C 10693	1	PART V - OOU REFERENCES FOR THE PERFORMANCE ASSESSMENT FOR THE F-TANK FARM AT THE SAVANNAH RIVER SITE (REDACTED VERSION) SRS-REG-2007-00002,	SRNS		SUPPORTING DOCUMENT	2219
✓017278	03/31/20	SRS-REG-2007-0C 10693	1	PART VI - OOU REFERENCES FOR THE PERFORMANCE ASSESSMENT FOR THE F-TANK FARM AT THE SAVANNAH RIVER SITE (REDACTED VERSION) SRS-REG-2007-00002,	SRNS		SUPPORTING DOCUMENT	1513
✓017279	03/31/20	SRS-REG-2007-0C 10693	1	PART VII - OOU REFERENCES FOR THE PERFORMANCE ASSESSMENT FOR THE F-TANK FARM AT THE SAVANNAH RIVER SITE (REDACTED VERSION) SRS-REG-2007-00002,	SRNS		SUPPORTING DOCUMENT	1447
✓017280	03/31/20	SRS-REG-2007-0C 10693	1	PART VIII - OOU REFERENCES FOR THE PERFORMANCE ASSESSMENT FOR THE F-TANK FARM AT THE SAVANNAH RIVER SITE (REDACTED VERSION) SRS-REG-2007-00002,	SRNS		SUPPORTING DOCUMENT	2326
✓017281	03/31/20	SRS-REG-2007-0C 10693	1	PART IX - OOU REFERENCES FOR THE PERFORMANCE ASSESSMENT FOR THE F-TANK FARM AT THE SAVANNAH RIVER SITE (REDACTED VERSION) SRS-REG-2007-00002,	SRNS		SUPPORTING DOCUMENT	1577
✓017282	03/31/20	SRS-REG-2007-0C 10693	1	PART X - OOU REFERENCES FOR THE PERFORMANCE ASSESSMENT FOR THE F-TANK FARM AT THE SAVANNAH RIVER SITE (REDACTED VERSION) SRS-REG-2007-00002,	SRNS		SUPPORTING DOCUMENT	1803
✓017283	03/31/20	SRS-REG-2007-0C 10693	1	PART XI - OOU REFERENCES FOR THE PERFORMANCE ASSESSMENT FOR THE F-TANK FARM AT THE SAVANNAH RIVER SITE (REDACTED VERSION) SRS-REG-2007-00002,	SRNS		SUPPORTING DOCUMENT	1541
✓017285	03/31/20	SRS-REG-2007-0C 10693	1	PART XII - OOU REFERENCES FOR THE PERFORMANCE ASSESSMENT FOR THE F-TANK FARM AT THE SAVANNAH RIVER SITE (REDACTED VERSION) SRS-REG-2007-00002,	SRNS		CORRESPONDENCE	2038
✓017286	03/31/20	SRS-REG-2007-0C 10693	1	PART XIII - OOU REFERENCES FOR THE PERFORMANCE ASSESSMENT FOR THE F-TANK FARM AT THE SAVANNAH RIVER SITE (REDACTED VERSION) SRS-REG-2007-00002,	SRNS		SUPPORTING DOCUMENT	2246
✓017287	03/31/20	SRS-REG-2007-0C 10693	1	PART XIV - OOU REFERENCES FOR THE PERFORMANCE ASSESSMENT FOR THE F-TANK FARM AT THE SAVANNAH RIVER SITE (REDACTED VERSION) SRS-REG-2007-00002,	SRNS		SUPPORTING DOCUMENT	1555
✓017288	03/31/20	SRS-REG-2007-0C 10693	1	PART XV - OOU REFERENCES FOR THE PERFORMANCE ASSESSMENT FOR THE F-TANK FARM AT THE SAVANNAH RIVER SITE (REDACTED VERSION) SRS-REG-2007-00002,	SRNS		SUPPORTING DOCUMENT	1576

ARF Index 580

Catalog Num	Date	Doc Number	Track #	Title	Author	Addressee	Doc Type	#of Pages
✓017289	03/31/20	SRS-REG-2007-0C REV. 1	10693	PART XVI - OJO REFERENCES FOR THE PERFORMANCE ASSESSMENT FOR THE F-TANK FARM AT THE SAVANNAH RIVER SITE (REDACTED VERSION) SRS-REG-2007-00002,	SRNS		SUPPORTING DOCUMENT	1652
✓017306	03/31/20	SRS-REG-2007-0C REV. 1	10693	PART XVII - SUPPORTING DOCUMENT NRC-SRR-CWDA-2009-00054, REVISION 0, COMMENT RESPONSE MATRIX FOR NUCLEAR REGULATORY	SRNS		SUPPORTING DOCUMENT	1043
✓017307	03/31/20	SRS-REG-2007-0C REV. 1	10693	PART XVIII - SUPPORTING DOCUMENT EPA-SRR-CWDA-2009-00055, REVISION 0, COMMENT RESPONSE MATRIX FOR ENVIRONMENTAL PROTECTION	SRNS		SUPPORTING DOCUMENT	675
✓017308	03/31/20	SRS-REG-2007-0C REV.1	10693	PART XIX - SUPPORTING DOCUMENT DHEC-SRR-CWDA-2009-00059, REVISION 0, COMMENT RESPONSE MATRIX FOR S.C. DEPARTMENT OF HEALTH &	SRNS		SUPPORTING DOCUMENT	989
✓017329	12/08/20	017329	10693	EPA COMMENTS ON THE DOE REQUEST FOR CONCURRENCE TO PROCEED TO SAMPLE AND ANALYSIS PHASE OF THE TANK CLOSURE PROCESS FOR TANKS 5	ROBERT POPE	B. T. HENNESSEY	CORRESPONDENCE	2
017466	03/07/20	WDPD-11-45	10693	DOE SUBMITTAL OF THE CALENDAR YEAR (CY) 2010 ANNUAL REPORT STATUS OF F/H AREA RADIOACTIVE LIQUID WASTE TANKS BEING REMOVED FROM SERVICE	BRIAN HENNESSEY	R.H. POPE/V. KEISLER	CORRESPONDENCE	2
017467	03/01/20	SRR-CES-2011-0C	10693	CALENDAR YEAR (CY) 2010 ANNUAL REPORT STATUS OF F/H AREA RADIOACTIVE LIQUID WASTE TANKS BEING REMOVED FROM SERVICE SRR-CES-2011-00002, DATED	SRR		SUPPORTING DOCUMENT	96
✚017540	04/07/20	ACP-11-186	10693	DOE SUBMITTAL OF THE OPTION PAPER FOR SAVANNAH RIVER SITE (SRS) LIQUID WASTE SYSTEM, NON-ENFORCEABLE SUBMITTAL DATES	BRIAN HENNESSEY	R.H. POPE/V. KEISLER	CORRESPONDENCE	6
✚017601	04/19/20	017601	10693	SCDHEC COMMENTS ON THE CALENDAR YEAR (CY) 2010 ANNUAL REPORT STATUS OF F/H AREA RADIOACTIVE LIQUID WASTE TANKS BEING REMOVED FROM SERVICE	VAN KEISLER	B. T. HENNESSEY	CORRESPONDENCE	2
✚017695	05/09/20	WDPD-11-47	10693	DOE SUBMITTAL OF THE COMPLETION OF BULK WASTE REMOVAL BWR EFFORTS IN TANK 11	BRIAN HENNESSEY	R.H. POPE/V. KEISLER	CORRESPONDENCE	22
✚017707	05/11/20	017707	10693	SCDHEC COMMENTS ON THE OPTION PAPER FOR SAVANNAH RIVER SITE SRS LIQUID WASTE SYSTEM NON-ENFORCEABLE FFA MILESTONES	VAN KEISLER	B. T. HENNESSEY		1
✚017712	05/11/20	017712	10693	EPA COMMENT ON THE SUBMITTAL OF THE OPTION PAPER FOR SAVANNAH RIVER SITE SRS LIQUID WASTE SYSTEM NON-ENFORCEABLE SUBMITTAL APRIL 7, 2011	ROBERT POPE	B. T. HENNESSEY	CORRESPONDENCE	2
✚017717	05/18/20	017717	10693	EPA APPROVAL OF THE COMPLETION OF BULK WASTE REMOVAL BWR EFFORTS IN TANK 11 AND CONTINUED USE OF TANK 11	ROBERT POPE	B. T. HENNESSEY	CORRESPONDENCE	2
✚017723	05/25/20	017723	10693	SCDHEC APPROVAL OF THE COMPLETION OF BULK WASTE REMOVAL BWR EFFORTS IN TANK 11 MAY 9, 2011 REFERENCED IN LETTER FROM HENNESSEY TO KEISLER	VAN KEISLER	B. T. HENNESSEY	CORRESPONDENCE	1
✚017728	06/01/20	WDPD-11-67	10693	DOE SUBMITTAL OF THE COMPLETION OF BULK WASTE REMOVAL BWR EFFORTS IN TANK 4	BRIAN HENNESSEY	R.H. POPE/V. KEISLER	CORRESPONDENCE	22

ARF Index 580

Catalog Num	Date	Doc Number	Track #	Title	Author	Addressee	Doc Type	#of Pages
+017780	06/08/20	017780	10693	SCDHEC APPROVAL OF THE LETTER HENNESSEY TO KEISLER AND POPE COMPLETION OF BULK WASTE REMOVAL BWR EFFORTS IN TANK 4 JUNE 2011	VAN KEISLER	B. T. HENNESSEY	CORRESPONDENCE	1
+017804	06/21/20	017804	10693	EPA CONCURRENCE FOR COMPLETION OF BULK WASTE REMOVAL BWR EFFORTS IN TANK 4	R. H. POPE	B. T. HENNESSEY	CORRESPONDENCE	2
+017813	06/28/20	017813	10693	EPA SUBMITTAL OF A LIST OF LIQUID WASTE DOCUMENTS BY LETTER FOR FY11 BY JULY 1 2011 REFERENCE LETTER POPE TO HENNESSY APRIL 27 2011	R. H. POPE	B. T. HENNESSEY	CORRESPONDENCE	2
+017827	05/17/20	SRR-CES-2011-00	10693	SRR SUBMITTAL LETTER FOR F AREA TANK FARM GROUNDWATER MONITORING PLAN	P. M. ALLEN	J. DEBESSONET	CORRESPONDENCE	2
+017828	05/01/20	SRNS-RP-2011-00	10693	F AREA TANK FARM GROUNDWATER MONITORING PLAN U MAY 2011	SRNS		SUPPORTING DOCUMENT	28
+017829	06/17/20	017829	10693	SCDHEC COMMENTS ON FAREA TANK FARM GROUNDWATER MONITORING PLAN U SRNS-RP-2011-00995 REVISION 0 MAY 2011 RECEIVED	V. KEISLER	B. T. HENNESSEY	CORRESPONDENCE	2
+017831	06/14/20	017831	10693	EPA COMMENTS ON F AREA TANK FARM GROUNDWATER MONITORING PLAN U SRNS-RP-2011-00995 REV 0 DATED MAY 2011	M. BERRY	V. KEISLER	CORRESPONDENCE	4
+017869	08/11/20	WDPD-11-75	10693	DOE SUBMITTAL OF THE COMPLETION OF BULK WASTE REMOVAL (BWR) EFFORTS IN TANK 7	B. T. HENNESSEY	R. POPE/V. KEISLER	CORRESPONDENCE	2
+017870	08/10/20	SRR-WRC-2011-0	10693	COMPLETION OF TANK 7F BULK WASTE REMOVAL EFFORTS	G. DICKERT/N. DAVIS		SUPPORTING DOCUMENT	20
+017878	08/12/20	WDPD-11-76	10693	DOE SUBMITTAL OF LIQUID WASTE NON-ENFORCEABLE MILESTONES BY LETTER	B. T. HENNESSEY	R. POPE/V. KEISLER	CORRESPONDENCE	4
+017888	08/16/20	017888	10693	EPA APPROVAL OF THE COMPLETION OF BULK WASTE REMOVAL (BWR) EFFORTS IN TANK 7	ROBERT H. POPE	B. T. HENNESSEY	CORRESPONDENCE	2
+017915	09/07/20	WDPD-11-80	10693	DOE SUBMITTAL OF THE APPROVAL TO TRANSFER SUPERNATE INTO TANK 8F	BRIAN HENNESSEY	R.H.POPE/VAN KEISLER	CORRESPONDENCE	2
+017922	09/14/20	017922	10693	EPA APPROVAL TO TRANSFER SUPERNATE INTO TANK 8F	ROBERT H. POPE	B. T. HENNESSEY	CORRESPONDENCE	1
+017924	09/14/20	017924	10693	SCDHEC APPROVAL OF THE LETTER, HENNESSEY TO KEISLER AND POPE, APPROVAL TO TRANSFER SUPERNATE INTO TANK 8F, DATED SEPTEMBER 7, 2011	VAN KEISLER	B. T. HENNESSEY	CORRESPONDENCE	1
+017930	08/17/20	017930	10693	SCDHEC APPROVAL OF THE LETTER, HENNESSEY TO KEISLER AND POPE, COMPLETION OF BULK WASTE REMOVAL (BWR) EFFORTS IN TANK 7, DATED AUGUST 11,	VAN KEISLER	B. T. HENNESSEY	CORRESPONDENCE	1

ARF Index 580

Catalog Num	Date	Doc Number	Track #	Title	Author	Addressee	Doc Type	#of Pages
†017986	11/02/20	017986	10693	NEWSPAPER ADVERTISEMENT - (THE PEOPLE SENTINEL) - ON THE PUBLIC NOTICE INDUSTRIAL WASTEWATER CLOSURE MODULE FOR THE LIQUID WASTE TANKS 18	SRNS		COMMUNITY INVOLVEMENT	2
†018033	10/21/20	SRR-CES-2011-00	10693	SRR SUBMITTAL LETTER FOR RESPONSES TO SCDHEC AND EPA REGION 4 COMMENTS F-AREA TANK FARM GROUNDWATER MONITORING PLAN,	P. ALLEN	V. KEISLER	CORRESPONDENCE	9
†018034	11/09/20	018034	10693	SCDHEC COMMENTS ON THE RESPONSES TO SCDHEC AND EPA REGION 4 COMMENTS ON THE F-AREA TANK FARM GROUNDWATER MONITORING PLAN (U)	V. KEISLER	O. STEVENS	CORRESPONDENCE	2
†018066	12/14/20	018066	10693	DRAFT F-AREA TANK FARM GROUNDWATER MONITORING PLAN (SRNS-RP-2011-00995, MAY 2011) COMMENT RESPONSES MATRIX FOR THE SCDHEC COMMENTS OF	M. GRIFFITH	M. BERRY/V. KEISLER	CORRESPONDENCE	6
†018067	01/06/20	018067	10693	SCDHEC COMMENTS ON THE F-AREA TANK FARM GROUNDWATER MONITORING PLAN,	V. KEISLER	O. STEVENS	CORRESPONDENCE	5
†018070	01/01/20	SRNS-RP-2012-00 REV 0	10693	SRNS-RP-2011-00995, MAY 2011 RESPONSES TO SCDHEC 2011 ANNUAL GROUNDWATER MONITORING REPORT FOR THE F- AND H-AREA RADIOACTIVE LIQUID WASTE TANK FARMS (U) SRNS-RP-2012-00022 REVISION 0	SRNS		SUPPORTING DOCUMENT	30
†018085	10/27/20	SRR-CWDA-2011-	10693	SRR TRANSMITTAL OF THE INDUSTRIAL WASTEWATER CLOSURE MODULE FOR THE LIQUID WASTE TANK 18 AND 19, F-AREA TANK FARM SAVANNAH RIVER SITE,	V.A.FRANKLIN	J.P. deBESSONET	CORRESPONDENCE	3
†018086	01/27/20	SRR-CWDA-2010- REV 1	10693	INDUSTRIAL WASTEWATER CLOSURE MODULE FOR THE LIQUID WASTE TANKS 18 AND 19 F-AREA TANK FARM, SAVANNAH RIVER SITE	SRR		SUPPORTING DOCUMENT	139
†018087	01/25/20	SRR-CWDA-2012-	10693	SRR TRANSMITTAL OF THE INDUSTRIAL WASTEWATER CLOSURE MODULE FOR THE LIQUID WASTE TANKS 18 AND 19, F-AREA TANK FARM SAVANNAH RIVER SITE,	V.A.FRANKLIN	J.P.deBESSONE	SUPPORTING DOCUMENT	2
†018088	01/25/20	SRR-CWDA-2010- REV 2	10693	INDUSTRIAL WASTEWATER CLOSURE MODULE FOR THE LIQUID WASTE TANKS 18 AND 19 F-AREA TANK FARM, SAVANNAH RIVER SITE	SRR		SUPPORTING DOCUMENT	140
†018089	08/12/20	SRR-CWDA-2011-	10693	SRR TRANSMITTAL OF THE INDUSTRIAL WASTEWATER CLOSURE MODULE FOR THE LIQUID WASTE TANKS 18 AND 19, F-AREA TANK FARM SAVANNAH RIVER SITE,	V.A.FRANKLIN	J.P. deBESSONET	CORRESPONDENCE	2
†018092	08/12/20	SRR-CWDA-2010- REV 0	10693	INDUSTRIAL WASTEWATER CLOSURE MODULE FOR THE LIQUID WASTE TANKS 18 AND 19 F-AREA TANK FARM SAVANNAH RIVER SITE	SRR		SUPPORTING DOCUMENT	134
†018095	02/01/20	WDPD-12-17	10693	DOE SUBMITTAL OF THE INTERIM ACTION STATEMENT OF BASIS/PROPOSED PLAN FOR THE F-TANK FARM, WASTE TANKS 17 AND 20 (SRR-CWDA-2011-00103, REVISION 0,	B. T. HENNESSEY	R. POPE/V. KEISLER	CORRESPONDENCE	28
†018096	01/01/20	SRR-CWDA-2011- REV 0	10693	INTERIM ACTION STATEMENT OF BASIS/PROPOSED PLAN FOR THE F-AREA TANK FARM, WASTE TANKS 17 AND 20 SRR-CWDA-2011-00103 REVISION 0 CERCLIS NUMBER: 23	SRR		INTERIM ACTION PROPOSED PLAN	32
†018097	07/01/20	SRR-CWDA-2011- REDLINE	10693	SCOPING SUMMARY FOR THE F-AREA TANK FARM, WASTE TANKS 17 AND 20 SRR-CWDA-2011-00112 JULY 2011	SRR		SUPPORTING DOCUMENT	21

ARF Index 580

Catalog Num	Date	Doc Number	Track #	Title	Author	Addressee	Doc Type	#of Pages
+018098	01/01/20	SRR-CWDA-2012-	10693	UNITED STATES DEPARTMENT OF ENERGY INTERIM ACTION STATEMENT OF BASIS/PROPOSED PLAN FACT SHEET FOR THE F-AREA TANK FARM WASTE TANKS 17	SRR		SUPPORTING DOCUMENT	3
+018114	02/10/20	018114	10693	SCDHEC COMMENTS ON THE SRS RESPONSES TO SCDHEC AND EPA COMMENTS TO THE FTF	V. KEISLER	O. STEVENS	CORRESPONDENCE	2
+018116	02/01/20	SRR-CES-2012-00	10693	GROUNDWATER MONITORING PLAN AND F-AREA TANK SRR SUBMITTAL LETTER RE: SRS RESPONSES TO SCDHEC AND EPA COMMENTS TO THE FTF	P. M. ALLEN	V. KEISLER	CORRESPONDENCE	21
+018117	02/01/20	SRNS-RP-2011-00	10693	GROUNDWATER MONITORING PLAN F-AREA TANK FARM GROUNDWATER MONITORING PLAN (U) SRNS-RP-2011-00995, REV. 1, FEBRUARY 2012 (DRAFT)	SRNS		SUPPORTING DOCUMENT	43
+018120	02/22/20	018120	10693	EPA LETTER IN SUPPORT OF OPERATIONAL CLOSURE OF F-AREA TANK FARM TANKS 18 AND 19	R. POPE	B. T. HENNESSEY	CORRESPONDENCE	1
+018122	02/16/20	SRR-CES-2012-00	10693	SRR SUBMITTAL LETTER RE: SRS RESPONSES TO SCDHEC COMMENTS TO THE FTF GROUNDWATER MONITORING PLAN	P. M. ALLEN	V. KEISLER	CORRESPONDENCE	4
+018123	02/01/20	SRNS-RP-2011-00	10693	F-AREA TANK FARM GROUNDWATER MONITORING PLAN SRNS-RP-2011-00995 REVISION 1 REDLINE FEBRUARY 2012	SRNS		SUPPORTING DOCUMENT	36
+018124	02/01/20	SRNS-RP-2011-00	10693	REV 1 REDLINE F-AREA TANK FARM GROUNDWATER MONITORING PLAN SRNS-RP-2011-00995 REVISION 1 FEBRUARY 2012	SRNS		SUPPORTING DOCUMENT	36
+018125	02/24/20	018125	10693	SCDHEC APPROVAL OF THE F-AREA TANK FARM GROUNDWATER MONITORING PLAN SRNS-RP-2011-00995 REVISION 1 FEBRUARY 2012 RECEIVED FEBRUARY 21	V. KEISLER	O. STEVENS	CORRESPONDENCE	1
+018126	02/28/20	WDPD-12-28	10693	DOE SUBMITTAL OF THE CALENDAR YEAR 2011 ANNUAL REPORT STATUS OF F AND H AREA RADIOACTIVE LIQUID WASTE TANKS BEING REMOVED FROM SERVICE	B. T. HENNESSEY	R. POPE/V. KEISLER	CORRESPONDENCE	2
+018127	03/01/20	SRR-CES-2012-00	10693	CALENDAR YEAR 2011 ANNUAL REPORT STATUS OF F AND H AREA RADIOACTIVE LIQUID WASTE TANKS BEING REMOVED FROM SERVICE SRR-CES-2012-00001 DATED	SRR		SUPPORTING DOCUMENT	94
+018134	03/02/20	WDPD-12-27	10693	DOE SUBMITTAL OF THE COMPLETION OF WASTE REMOVAL IN TANKS 18 AND 19	B. T. HENNESSEY	R. POPE/V. KEISLER	CORRESPONDENCE	2
+018141	03/07/20	018141	10693	EPA CONCURRENCE WITH DOE'S LETTER CONCERNING COMPLETION OF WASTE REMOVAL IN TANKS 18 AND 19	R.H. POPE	B. T. HENNESSEY	CORRESPONDENCE	1
+018142	03/07/20	018142	10693	SCDHEC APPROVAL OF SAVANNAH RIVER SITE (F-AREA TANK FARM) 1.INDUSTRIAL WASTEWATER CLOSURE MODULE FOR THE LIQUID WASTE TANKS 18 AND 19,	J.P. deBESSONET	V.A. FRANKLIN	CORRESPONDENCE	1
+018161	03/29/20	018161	10693	SCDHEC APPROVAL OF THE CY2011 ANNUAL REPORT STATUS OF F/H AREA RADIOACTIVE LIQUID WASTE TANKS BEING REMOVED FROM SERVICE	V. KEISLER	B. T. HENNESSEY	CORRESPONDENCE	1

ARF Index 580

Catalog Num	Date	Doc Number	Track #	Title	Author	Addressee	Doc Type	#of Pages
+018165	04/09/20	WDPD-12-40	10693	DOE SUBMITTAL OF LIST OF LIQUID WASTE MILESTONES BY LETTER	B. T. HENNESSEY	R. POPE/V. KEISLER	CORRESPONDENCE	3
+018166	03/29/20	018166	10693	EPA COMMENTS ON INTERIM ACTION STATEMENT OF BASIS PROPOSED PLAN SOB PP FOR THE F AREA TANK FARM WASTE TANKS 17 AND 20 SRR-CWDA-2011-00103	MARTHA BERRY	B. T. HENNESSEY	CORRESPONDENCE	4
+018260	04/17/20	018260	10693	EPA COMMENTS ON THE CY2011 ANNUAL REPORT STATUS OF F H AREA RADIOACTIVE LIQUID WASTE TANKS BEING REMOVED FROM SERVICE	MARTHA BERRY	B. T. HENNESSEY	CORRESPONDENCE	6
+018324	06/01/20	WDPD-12-50	10693	DOE SUBMITTAL OF THE INTERIM ACTION STATEMENT OF BASIS/PROPOSED PLAN FOR THE F TANK FARM WASTE TANKS 17 AND 20 SRR-CWDA-2011-00103 REDLINE	B. T. HENNESSEY	R. H. POPE/V. KEISLER	CORRESPONDENCE	8
+018325	05/01/20	SRR-CWDA-2011-REV 1	10693	INTERIM ACTION STATEMENT OF BASIS/PROPOSED PLAN FOR THE F AREA TANK FARM WASTE TANKS 17 AND 20 CERCLIS NUMBER 23 SRR-CWDA-2011-00103 REVISION 1	SRR		CORRESPONDENCE	33
+018335	01/24/20	LWO-RIP-2009-00-REV 3	10693	INDUSTRIAL WASTEWATER GENERAL CLOSURE PLAN FOR F-AREA WASTE TANK SYSTEMS LWO-RIP-2009-00009 REV 3 DATED JANUARY 24 2011	SRR		SUPPORTING DOCUMENT	53
+018339	01/08/97	PIT-MISC-0002 REV 1	10693	INDUSTRIAL WASTEWATER CLOSURE MODULE FOR THE HIGH-LEVEL WASTE TANK 20 SYSTEM PIT-MISC-0002 REV 1 DATED JANUARY 8 1997	SRNS		SUPPORTING DOCUMENT	165
+018340	08/26/97	PIT-MISC-0004 REV 2	10693	INDUSTRIAL WASTEWATER CLOSURE MODULE FOR THE HIGH-LEVEL WASTE TANK 17 SYSTEM PIT-MISC-0004 REVISION 2 DATED AUGUST 26 1997	SRNS		SUPPORTING DOCUMENT	165
+018359	07/10/96	PIT-MISC-00006 REV 1	10693	INDUSTRIAL WASTEWATER CLOSURE PLAN FOR F AND H AREA HIGH LEVEL WASTE TANK SYSTEMS PIT-MISC-00006 REV 1 DATED JULY 10 1996	SRNS		SUPPORTING DOCUMENT	323
+018386	06/29/20	018386	10693	SCDHEC APPROVAL OF THE INTERIM ACTION STATEMENT OF BASIS PROPOSED PLAN FOR THE F-AREA TANK FARM WASTE TANKS 17 AND 20 CERCLIS NUMBER	V. KEISLER	B. T. HENNESSEY	CORRESPONDENCE	1
+018390	07/03/20	018390	10693	EPA CONCURRENCE OF THE INTERIM ACTION STATEMENT OF BASIS PROPOSED PLAN SOB PP FOR THE F-AREA TANK FARM WASTE TANKS 17 AND 20	M. BERRY	B. T. HENNESSEY	CORRESPONDENCE	1
+018398	07/19/20	018398	10693	EPA APPROVAL OF THE INTERIM ACTION STATEMENT OF BASIS/PROPOSED PLAN SOB/PP FOR THE F AREA TANK FARM WASTE TANKS 17 AND 20 SRR-CWDA-2011-00103	MARTHA BERRY	BRIAN HENNESSEY	CORRESPONDENCE	1
+018411	05/01/20	SRR-CWDA-2011-REV 1	10693	INTERIM ACTION STATEMENT OF BASIS PROPOSED PLAN FOR THE F-AREA TANK FARM WASTE TANKS 17 AND 20 CERCLIS NUMBER 23 SRR-CWDA-2011-00103 REVISION 1	SRR		STATEMENT OF BASIS / PROPOSED PLAN	33
+018412	05/01/20	SRR-CWDA-2012-REV 0	10693	UNITED STATES DEPARTMENT OF ENERGY INTERIM ACTION STATEMENT OF BASIS/PROPOSED PLAN FACT SHEET FOR THE F-AREA TANK FARM WASTE TANKS 17	SRR		SUPPORTING DOCUMENT	3
+018413	08/02/20	SRR-CES-2012-00	10693	SRR SUBMITTAL OF THE F-AREA TANK FARM GROUNDWATER SAMPLING AND ANALYSIS PLAN SRNS-RP-2012-00287 REV 0 AND H-AREA TANK FARM	P. ALLEN	V. KEISLER	CORRESPONDENCE	2

ARF Index 580

Catalog Num	Date	Doc Number	Track #	Title	Author	Addressee	Doc Type	#of Pages
+018414	07/01/20	SRNS-RP-2012-00 REV 0	10693	F-AREA TANK FARM GROUNDWATER SAMPLING AND ANALYSIS PLAN SRNS-RP-2012-00287 REVISION 0 JULY 2012	SRNS		SUPPORTING DOCUMENT	64
+018436	08/14/20	018436	10693	NEWSPAPER ADVERTISEMENT AIKEN STANDARD ON THE INTERIM ACTION STATEMENT OF BASIS PROPOSED PLAN FOR THE F-AREA TANK FARM WASTE TANKS 17 AND 20	SRNS		COMMUNITY INVOLVEMENT	1
+018437	08/15/20	018437	10693	NEWSPAPER ADVERTISEMENT THE PEOPLE SENTINEL ON THE INTERIM ACTION STATEMENT OF BASIS PROPOSED PLAN FOR THE F-AREA TANK FARM WASTE	SRNS		COMMUNITY INVOLVEMENT	2
+018452	09/05/20	WDPD-12-75	10693	DOE SUBMITTAL OF THE COMPLETION OF OPERATIONAL CLOSURE OF TANKS 19 AND 18	BRIAN T. HENNESSEY	ROBERT H. POPE/VAN KEISLER	CORRESPONDENCE	2
+018455	08/30/20	018455	10693	SCDHEC AND EPA COMMENTS ON THE F-AREA TANK FARM GROUNDWATER SAMPLING AND ANALYSIS PLAN SRNS-RP-2012-00287 REVISION 0 JULY 2012	V. KEISLER	B. HENNESSEY	CORRESPONDENCE	8
+018462	08/14/20	018462	10693	NEWSPAPER ADVERTISEMENT THE STATE ON THE INTERIM ACTION STATEMENT OF BASIS/PROPOSED PLAN F-AREA TANK FARM WASTE TANKS 17 AND 20 AT THE	SRNS		COMMUNITY INVOLVEMENT	2
+018464	08/31/20	018464	10693	RADIO ANNOUNCEMENT WKXC-FM ON THE INTERIM ACTION STATEMENT OF BASIS/PROPOSED PLAN F-AREA TANK FARM WASTE TANKS 17 AND 20	SRNS		COMMUNITY INVOLVEMENT	1
+018490	08/14/20	018490	10693	NEWSPAPER ADVERTISEMENT THE AUGUSTA CHRONICLE ON THE INTERIM ACTION STATEMENT OF BASIS/PROPOSED PLAN F-AREA TANK FARM WASTE	SRNS		COMMUNITY INVOLVEMENT	2
+018492	09/19/20	018492	10693	SCDHEC RESPONSE TO LETTER HENNESSEY TO KEISLER AND POPE COMPLETION OF OPERATIONAL CLOSURE OF TANKS 19 AND 18 DATED SEPTEMBER 5,	V. KEISLER	B. HENNESSEY	CORRESPONDENCE	1
+018526	10/11/20	WDPD-13-03	10693	DOE SUBMITTAL OF THE INTERIM RECORD OF DECISION REMEDIAL ALTERNATIVE SELECTION FOR THE F AREA TANK FARM WASTE TANKS 17 AND 20 U	BRIAN T. HENNESSEY	ROBERT H. POPE/VAN KEISLER	CORRESPONDENCE	2
+018527	10/01/20	SRR-CWDA-2012-	10693	INTERIM RECORD OF DECISION REMEDIAL ALTERNATIVE SELECTION FOR THE F AREA TANK FARM WASTE TANKS 17 AND 20 U CERCLIS NUMBER 23 SRR-CWDA-2012-00111	SRNS		SUPPORTING DOCUMENT	54
+018528	09/19/20	018528	10693	EPA RESPONSE TO LETTER HENNESSEY TO KEISLER AND POPE COMPLETION OF OPERATIONAL CLOSURE OF TANKS 19 AND 18 DATED SEPTEMBER 5 2012	ROBERT H. POPE	BRIAN T. HENNESSEY	CORRESPONDENCE	2
+018572	12/10/20	018572	10693	SCDHEC APPROVAL OF THE F AREA TANK FARM GROUNDWATER SAMPLING AND ANALYSIS PLAN U SRNS-RP-2012-00287 REVISION 1 NOVEMBER 2012	VAN KEISLER	BRIAN T. HENNESSEY	CORRESPONDENCE	1
+018605	11/14/20	SRNS-RP-2012-00 REV.1	10693	SRR SUBMITTAL OF THE F AREA TANK FARM GROUNDWATER SAMPLING AND ANALYSIS PLAN SRNS-RP-2012-00287 REVISION 1 NOVEMBER 2012	PATRICIA M. ALLEN	VAN KEISLER	SUPPORTING DOCUMENT	128
+018618	11/29/20	018618	10693	EPA APPROVAL OF THE F AREA TANK FARM GROUNDWATER SAMPLING AND ANALYSIS PLAN U SRNS-RP-2012-00287 REVISION 1 NOVEMBER 2012 AND H	MARTHA BERRY	VAN KEISLER	CORRESPONDENCE	1

ARF Index 580

Catalog Num	Date	Doc Number	Track #	Title	Author	Addressee	Doc Type	#of Pages
+018619	12/11/20	018619	10693	EPA COMMENTS ON THE INTERIM RECORD OF DECISION (IROD) REMEDIAL ALTERNATIVE SELECTION FOR THE F-AREA TANK FARM, WASTE TANKS 17 AND 20,	MARTHA BETTY	BRIAN T. HENNESSEY	CORRESPONDENCE	2
+018621	12/10/20	018621	10693	SCDHEC COMMENTS ON THE INTERIM RECORD OF DECISION/REMEDIAL ALTERNATIVE SELECTION FOR THE F-AREA TANK FARM, WASTE TANKS 17 AND 20 (U),	VAN KEISLER	BRIAN T. HENNESSEY	CORRESPONDENCE	2
+018669	01/01/20	SRR-CWDA-2012-REV 0	10693	INDUSTRIAL WASTEWATER CLOSURE MODULE FOR THE LIQUID WASTE TANKS 5F AND 6F F-AREA TANK FARM SAVANNAH RIVER SITE PERMIT NO 17,424-IW	SRR		SUPPORTING DOCUMENT	181
+018689	02/15/20	WDPD-13-33	10693	DOE SUBMITTAL OF THE INTERIM RECORD OF DECISION REMEDIAL ALTERNATIVE SELECTION FOR THE F-AREA TANK FARM WASTE TANKS 17 AND 20	BRIAN T. HENNESSEY	ROBERT H. POPE VAN KEISLER	CORRESPONDENCE	4
+018690	01/01/20	SRR-CWDA-2012-REV 1 REDLINE	10693	INTERIM RECORD OF DECISION REMEDIAL ALTERNATIVE SELECTION FOR THE F-AREA TANK FARM WASTE TANKS 17 AND 20 SRR-CWDA-2012-00111 REVISION 1 REDLINE	SRR		SUPPORTING DOCUMENT	55
+018708	02/27/20	WDPD-13-36	10693	DOE SUBMITTAL OF THE CALENDAR YEAR CY2012 ANNUAL REPORT STATUS OF F/H AREA RADIOACTIVE LIQUID WASTE TANKS BEING REMOVED FROM SERVICE	BRIAN T. HENNESSEY	ROBERT H. POPE VAN KEISLER	CORRESPONDENCE	2
+018709	03/01/20	SRR-ESH-2013-00	10693	CY2012 ANNUAL REPORT STATUS OF F/H AREA RADIOACTIVE LIQUID WASTE TANKS BEING REMOVED FROM SERVICE SRR-ESH-2013-00005 MARCH 2013	SRR		SUPPORTING DOCUMENT	37
+018711	03/01/20	WDPD-13-35	10693	DOE SUBMITTAL OF THE APPROVAL FOR CONTINUED USAGE OF HIGH LEVEL WASTE TANKS 7F AND 11H	BRIAN T. HENNESSEY	ROBERT H. POPE VAN KEISLER	CORRESPONDENCE	2
+018712	02/21/20	SRR-LWP-2013-00	10693	ADDITIONAL TYPE I TANK USAGE POST-BULK WASTE REMOVAL EFFORTS BWRE BRIEFING TO SCDHEC AND EPA SRR-LWP-2013-00012	MARK MAHONEY KARTHIK SUBRAMANIAN JASON VITALI		SUPPORTING DOCUMENT	32
+018723	02/19/20	018723	10693	NEWSPAPER ADVERTISEMENT THE AUGUSTA CHRONICLE INDUSTRIAL WASTEWATER CLOSURE MODULE FOR LIQUID WASTE TANKS 5F AND 6F F-AREA	SRR		SUPPORTING DOCUMENT	1
+018724	02/19/20	018724	10693	NEWSPAPER ADVERTISEMENT AIKEN STANDARD INDUSTRIAL WASTEWATER CLOSURE MODULE FOR LIQUID WASTE TANKS 5F AND 6F F-AREA TANK FARM	SRNS		SUPPORTING DOCUMENT	1
+018728	03/07/20	018728	10693	EPA APPROVAL OF THE LETTER HENNESSEY TO KEISLER AND POPE APPROVAL FOR CONTINUED USAGE OF HIGH LEVEL WASTE TANKS 7F AND 11H DATED MARCH 1 2013	ROBERT H. POPE	BRIAN T. HENNESSEY	CORRESPONDENCE	2
+018729	03/07/20	018729	10693	SCDHEC APPROVAL OF THE LETTER HENNESSEY TO KEISLER AND POPE APPROVAL FOR CONTINUED USAGE OF HIGH LEVEL WASTE TANKS 7F AND 11H DATED	VAN KEISLER	BRIAN T. HENNESSEY	CORRESPONDENCE	1
+018749	03/18/20	ARF-018749	10693	EPA APPROVAL OF THE INTERIM RECORD OF DECISION (IROD) REMEDIAL ALTERNATIVE SELECTION FOR THE F-AREA TANK FARM WASTE TANKS 17 AND 20	MARTHA BERRY	BRIAN HENNESSEY	CORRESPONDENCE	1
+018750	03/14/20	ARF-018750	10693	SCDHEC APPROVAL OF THE INTERIM RECORD OF DECISION / REMEDIAL ALTERNATIVE SELECTION FOR THE F-AREA TANK FARM WASTE TANKS 17 AND 20 (U)	VAN KEISLER	BRIAN T. HENNESSEY	CORRESPONDENCE	1

ARF Index 580

Catalog Num	Date	Doc Number	Track #	Title	Author	Addressee	Doc Type	#of Pages
+018752	03/11/20	WDPD-13-39	10693	DOE SUBMITTAL OF THE EXPLANATION OF SIGNIFICANT DIFFERENCE ESD FOR THE REVISION 1 INTERIM RECORD OF DECISION REMEDIAL ALTERNATIVE SELECTION FOR	BRIAN T. HENNESSEY	ROBERT H. POPE VAN KEISLER	CORRESPONDENCE	2
+018753	03/01/20	SRR-CWDA-2013-REV 0	10693	EXPLANATION OF SIGNIFICANT DIFFERENCE ESD FOR THE REVISION 1 INTERIM RECORD OF DECISION REMEDIAL ALTERNATIVE SELECTION FOR THE F AREA	SRR		SUPPORTING DOCUMENT	15
+018761	03/25/20	018761	10693	DOE SUBMITTAL OF THE SIGNED INTERIM RECORD OF DECISION REMEDIAL ALTERNATIVE SELECTION FOR THE F TANK FARM WASTE TANKS 17 AND 20 U	BRIAN T. HENNESSEY	VAN KEISLER ROBERT H. POPE	CORRESPONDENCE	2
+018762	01/01/20	SRR-CWDA-2012-REV 1	10693	INTERIM RECORD OF DECISION REMEDIAL ALTERNATIVE SELECTION FOR THE F AREA TANK FARM WASTE TANKS 17 AND 20 U CERCLIS NUMBER 23 SRR-CWDA-2012-00111	SRR		SUPPORTING DOCUMENT	54
+018923	04/15/20	018923	10693	SCDHEC SUBMITTAL OF THE SIGNED INTERIM RECORD OF DECISION/REMEDIAL ALTERNATIVE SELECTION FOR THE F-AREA TANK FARM WASTE TANKS 17 AND 20	VAN KEISLER	BRIAN T. HENNESSEY	CORRESPONDENCE	1
+018924	01/01/20	SRR-CWDA-2012-REV 1	10693	THREE PARTY SIGNED INTERIM RECORD OF DECISION REMEDIAL ALTERNATIVE SELECTION FOR THE F-AREA TANK FARM WASTE TANKS 17 AND 20 CERCLIS NUMBER	SRR		SUPPORTING DOCUMENT	54
+018934	04/02/20	018934	10693	EPA SUBMITTAL OF THE INTERIM RECORD OF DECISION IROD REMEDIAL ALTERNATIVE SELECTION FOR THE F-AREA TANK FARM WASTE TANKS 17 AND 20	MARTHA BERRY	VAN KEISLER	CORRESPONDENCE	2
+018938	04/26/20	WDPD-13-50	10693	DOE SUBMITTAL OF THE COMPLETION OF WASTE REMOVAL IN TANKS 5 AND 6 CERCLIS NUMBER 23	BRIAN T. HENNESSEY	ROBERT H. POPE VAN KEISLER	CORRESPONDENCE	2
+018946	05/02/20	018946	10693	DOE SUBMITTAL OF THE THREE PARTY SIGNED INTERIM RECORD OF DECISION REMEDIAL ALTERNATIVE SELECTION FOR THE F TANK FARM WASTE TANKS 17	BRIAN T. HENNESSEY	ROBERT H. POPE VAN KEISLER	SUPPORTING DOCUMENT	2
+018951	03/27/20	SRR--ESH-2013-0	10693	2012 ANNUAL GROUNDWATER MONITORING REPORT U	PATRICIA M ALLEN	VAN KEISLER	CORRESPONDENCE	3
+018952	03/01/20	SRNS-RP-2013-00 REV 0	10693	2012 ANNUAL GROUNDWATER MONITORING REPORT FOR THE F AND H AREA RADIOACTIVE LIQUID WASTE TANK FARMS U CERCLIS NUMBER 23 & 89	SRNS		SUPPORTING DOCUMENT	68
+018994	05/06/20	018994	10693	SCDHEC COMMENTS ON THE 2012 ANNUAL GROUNDWATER MONITORING REPORT U CERCLIS NUMBER 28 AND 89 SRNS-RP-2013-00118 REVISION 0	VAN KEISLER	PATRICIA M ALLEN	CORRESPONDENCE	2
+018996	05/07/20	018996	10693	SCDHEC COMMENTS ON THE EXPLANATION OF SIGNIFICANT DIFFERENCE ESD FOR THE REVISION 1 INTERIM RECORD OF DECISION REMEDIAL ALTERNATIVE	VAN KEISLER	BRIAN T. HENNESSEY	CORRESPONDENCE	2
+018997	05/08/20	018997	10693	EPA CONCURRENCE OF THE EXPLANATION OF SIGNIFICANT DIFFERENCE ESD FOR THE REVISION 1 INTERM RECORD OF DECISION REMEDIAL ALTERNATIVE	MARTHA BERRY	BRIAN T. HENNESSEY	CORRESPONDENCE	1
+019003	05/14/20	019003	10693	EPA COMMENTS ON THE 2012 ANNUAL GROUNDWATER MONITORING REPORT FOR THE F AND H AREA RADIOACTIVE LIQUID WASTE TANK FARMS	MARTHA BERRY	PATRICIA M. ALLEN	CORRESPONDENCE	2

ARF Index 580

Catalog Num	Date	Doc Number	Track #	Title	Author	Addressee	Doc Type	#of Pages
+019011	05/16/20	SRNS-OS-2013-00	10693	SCDHEC LETTER REGARDING SAVANNAH RIVER SITE SC1 890 008 989 FINAL PERMIT DECISION FOR B AREA OPERABLE UNIT AND THE F AREA TANK FARM WASTE	RICHARD HAYNES	KEVIN M. KOSTELNIK	CORRESPONDENCE	10
+019012	05/15/20	019012	10693	SCDHEC AGREEMENT REGARDING COMPLETION OF WASTE REMOVAL IN TANKS 5 AND 6 LETTER HENNESSEY TO KEISLER AND POPE DATED APRIL 26 2013 CERCLIS	VAN KEISLER	BRIAN T. HENNESSEY	CORRESPONDENCE	1
+019021	04/30/20	019021	10693	NEWSPAPER ADVERTISEMENT AIKEN STANDARD PUBLIC NOTICE - NOTICE OF AVAILABILITY INTERIM RECORD OF DECISION FOR THE F-AREA TANK FARM WASTE TANKS 17	SRNS		COMMUNITY INVOLVEMENT	1
+019022	05/01/20	019022	10693	NEWSPAPER ADVERTISEMENT THE PEOPLE SENTINEL PUBLIC NOTICE - NOTICE OF AVAILABILITY INTERIM RECORD OF DECISION FOR THE F-AREA TANK FARM	SRNS		COMMUNITY INVOLVEMENT	2
+019023	04/30/20	019023	10693	NEWSPAPER ADVERTISEMENT THE STATE PUBLIC NOTICE - NOTICE OF AVAILABILITY INTERIM RECORD OF DECISION FOR THE F-AREA TANK FARM WASTE TANKS 17	SRNS		COMMUNITY INVOLVEMENT	2
+019030	06/05/20	019030	10693	DOE SUBMITTAL OF THE EXPLANATION OF SIGNIFICANT DIFFERENCE (ESD) FOR INCORPORATING TANKS 18 AND 19 INTO THE REVISION 1 INTERIM RECORD OF DECISION	BRIAN T. HENNESSEY	ROBERT H. POPE VAN KEISLER	CORRESPONDENCE	3
+019031	05/01/20	SRR-CWDA-2013-REDLINE REV 1	10693	EXPLANATION OF SIGNIFICANT DIFFERENCE (ESD) FOR INCORPORATING TANKS 18 AND 19 INTO THE REVISION 1 INTERIM RECORD OF DECISION REMEDIAL ALTERNATIVE	SRR		SUPPORTING DOCUMENT	15
+019032	05/15/20	019032	10693	EPA AGREEMENT REGARDING COMPLETION OF WASTE REMOVAL IN TANKS 5 AND 6 LETTER HENNESSEY TO KEISLER AND POPE DATED APRIL 26 2013 CERCLIS	ROBERT H. POPE	BRIAN T. HENNESSEY	CORRESPONDENCE	2
+019048	06/21/20	019048	10693	DOE SUBMITTAL OF THE INTERIM CORRECTIVE MEASURES IMPLEMENTATION/REMEDIAL ACTION IMPLEMENTATION PLAN (ICMI/RAIP) FOR THE F-AREA	BRIAN T. HENNESSEY	ROBERT H. POPE/ VAN KEISLER	CORRESPONDENCE	2
+019049	06/01/20	SRR-CWDA-2013-REV 0	10693	INTERIM CORRECTIVE MEASURES IMPLEMENTATION/REMEDIAL ACTION IMPLEMENTATION PLAN (ICMI/RAIP) FOR THE F-AREA TANK FARM, WASTE	SRR		SUPPORTING DOCUMENT	22
+019065	07/01/20	019065	10693	SCDHEC COMMENTS ON THE EXPLANATION OF SIGNIFICANT DIFFERENCE (ESD) FOR INCORPORATING TANKS 18 AND 19 INTO THE REVISION 1 INTERIM RECORD	VAN KEISLER	BRIAN T. HENNESSEY	CORRESPONDENCE	2
+019077	07/12/20	WDPD-13-73	10693	DOE SUBMITTAL OF THE NEED FOR CONTINUED USAGE OF HIGH LEVEL WASTE TANKS 4F AND 7F	BRIAN T. HENNESSEY	ROBERT H. POPE/ VAN KEISLER	CORRESPONDENCE	6
+019078	06/01/20	SRR-LWP-2013-00	10693	SAVANNAH RIVER SITE LIQUID WASTE PROGRAM PAST PROGRESS AND FUTURE PROSPECT	SRR		SUPPORTING DOCUMENT	21
+019079	06/01/20	SRR-LWP-2013-00 REV 0	10693	ADDITIONAL TYPE I TANK USAGE POST-BULK WASTE REMOVAL EFFORTS (BWRE)	SRR		SUPPORTING DOCUMENT	32
+019080	06/17/20	SRR-LWP-2013-00	10693	FOLLOWUP FROM JUNE 6 DISCUSSION REGARDING LW SYSTEM PLAN DRAFT REV. 18 RESULTS	SRR		SUPPORTING DOCUMENT	15

ARF Index 580

Catalog Num	Date	Doc Number	Track #	Title	Author	Addressee	Doc Type	#of Pages
+019084	07/19/20	WDPD-13-74	10693	DOE SUBMITTAL OF THE U.S. DEPARTMENT OF ENERGY SIGNED EXPLANATION OF SIGNIFICANT DIFFERENCE ESD FOR INCORPORATING TANKS 18 AND 19 INTO THE	BRIAN T. HENNESSEY	ROBERT H. POPE VAN KEISLER	SUPPORTING DOCUMENT	3
+019085	07/01/20	SRR-CWDA-2013-REV 1.1	10693	U.S. DEPARTMENT OF ENERGY SIGNED EXPLANATION OF SIGNIFICANT DIFFERENCE ESD FOR INCORPORATING TANKS 18 AND 19 INTO THE REVISION 1 INTERIM RECORD			SUPPORTING DOCUMENT	16
+019094	08/06/20	WDPD-13-77	10693	DOE SUBMITTAL OF THE SUBMITTAL OF LIST OF LIQUID WASTE MILESTONES BY LETTER	HENNESSEY,BRIAN T	ROBERT H. POPE, VAN KEISLER	CORRESPONDENCE	3
+019105	08/15/20	019105	10693	EPA SUBMITTAL OF THE EXPLANATION OF SIGNIFICANT DIFFERENCE (ESD) FOR INCORPORATING TANKS 18 AND 19 INTO THE REVISION 1 INTERIM RECORD OF DECISION	MARTHA BERRY	VAN KEISLER	CORRESPONDENCE	2
+019109	08/26/20	019109	10693	SCDHEC SUBMITTAL OF THE SIGNED EXPLANATION OF SIGNIFICANT DIFFERENCE ESD FOR INCORPORATING TANKS 18 AND 19 INTO THE REVISION 1 INTERIM RECORD	VAN KEISLER	BRIAN T. HENNESSEY	CORRESPONDENCE	1
+019110	07/01/20	SRR-CWDA-2013-REV 1.1	10693	THREE PARTY SIGNED EXPLANATION OF SIGNIFICANT DIFFERENCE ESD FOR INCORPORATING TANKS 18 AND 19 INTO THE REVISION 1 INTERIM RECORD OF DECISION	SRR		RECORD OF DECISION	16
+019112	09/04/20	019112	10693	EPA COMMENTS ON THE INTERIM CORRECTIVE MEASURES IMPLEMENTATION/REMEDIAL ACTION IMPLEMENTATION PLAN (ICMI/RAIP) FOR THE F-AREA	MARTHA BERRY	BRIAN T. HENNESSEY	CORRESPONDENCE	4
+019124	09/12/20	019124	10693	SCDHEC APPROVAL OF THE INTERIM CORRECTIVE MEASURES IMPLEMENTATION / REMEDIAL ACTION IMPLEMENTATION PLAN (ICMI/RAIP) FOR THE F-AREA	VAN KEISLER	BRIAN T. HENNESSEY	CORRESPONDENCE	1
+019139	09/27/20	WDPD-13-88	10693	DOE SUBMITTAL OF THE THREE PARTY SIGNED EXPLANATION OF SIGNIFICANT DIFFERENCE ESD FOR INCORPORATING TANKS 18 AND 19 INTO THE REVISION 1	BRIAN T. HENNESSEY	ROBERT H. POPE VAN KEISLER	CORRESPONDENCE	2
+019164	10/10/20	019164	10693	SCDHEC APPROVAL OF THE 2012 ANNUAL GROUNDWATER MONITORING REPORT FOR THE F AREA AND H AREA RADIOACTIVE LIQUID WASTE TANK FARM U	VAN KEISLER	PATRICIA M ALLEN	CORRESPONDENCE	1
+019166	10/02/20	SRNS-OS-2013-0C	10693	SCDHEC LETTER RE: SAVANNAH RIVER SITE - SC1 890 008 989 FINAL PERMIT DECISION FOR F AREA TANK FARM WASTE TANKS 18 AND 19	RICHARD HAYNES	KEVIN M KOSTELNIK	CORRESPONDENCE	8
+019170	10/02/20	019170	10693	SCDHEC RESPONSE TO JULY 12 2013 LETTER HENNESSEY TO KEISLER AND POPE NEED FOR CONTINUED USAGE OF HIGH LEVEL WASTE TANKS 4F	VAN KEISLER	BRIAN T. HENNESSEY	CORRESPONDENCE	2
+019173	09/10/20	SRR-ESH-2013-0C	10693	REVISION TO THE 2012 ANNUAL GROUNDWATER MONITORING REPORT U	PATRICIA M. ALLEN	MARTHA BERRY VAN KEISLER	SUPPORTING DOCUMENT	3
+019174	06/21/20	SRR-ESH-2013-0C	10693	RESPONSE TO COMMENTS ON 2012 ANNUAL GROUNDWATER MONITORING REPORT U	PATRICIA M. ALLEN	MARTHA BERRY VAN KEISLER	SUPPORTING DOCUMENT	8
+019175	07/01/20	SRNS-RP-2013-0C	10693	2012 ANNUAL GROUNDWATER MONITORING REPORT FOR THE F AND H AREA RADIOACTIVE LIQUID WASTE TANK FARMS U CERCLIS NUMBER 23 & 89	SRNS		SUPPORTING DOCUMENT	60

ARF Index 580

Catalog Num	Date	Doc Number	Track #	Title	Author	Addressee	Doc Type	#of Pages
+019247	11/19/20	019247	10693	EPA RESPONSE TO JULY 12 2013 LETTER HENNESSEY TO KEISLER AND POPE NEED FOR CONTINUED USAGE OF HIGH LEVEL WASTE TANKS 4F AND 7F	ROBERT H. POPE	BRIAN T. HENNESSEY	CORRESPONDENCE	2
+019258	12/19/20	WDPD-14-16	10693	DOE SUBMITTAL OF THE COMPLETE OPERATIONAL CLOSURE OF TANKS 5 AND 6	BRIAN T. HENNESSEY	VAN KEISLER	CORRESPONDENCE	2
+019261	12/17/20	WDPD-14-11	10693	DOE SUBMITTAL OF THE INTERIM CORRECTIVE MEASURES IMPLEMENTATION/REMEDIAL ACTION IMPLEMENTATION PLAN (ICMI/RAIP) FOR THE F-AREA	BRIAN T. HENNESSEY	ROBERT H. POPE VAN KEISLER	CORRESPONDENCE	2
+019262	12/01/20	SRR-CWDA-2013-REDLINE REV 1	10693	INTERIM CORRECTIVE MEASURES IMPLEMENTATION/REMEDIAL ACTION IMPLEMENTATION PLAN (ICMI/RAIP) FOR THE F-AREA TANK FARM WASTE	SRR		SUPPORTING DOCUMENT	26
+019263	12/01/20	SRR-CWDA-2013-REV 0	10693	INTERIM CORRECTIVE MEASURES IMPLEMENTATION/REMEDIAL ACTION IMPLEMENTATION PLAN (ICMI/RAIP) FOR THE F-AREA TANK FARM WASTE	SRR		SUPPORTING DOCUMENT	7
+019298	01/16/20	019298	10693	SCDHEC APPROVAL OF THE INTERIM CORRECTIVE MEASURES IMPLEMENTATION/REMEDIAL ACTION IMPLEMENTATION PLAN (ICMI/RAIP) FOR THE F-AREA	VAN KEISLER	BRIAN HENNESSEY	CORRESPONDENCE	1
+019300	01/16/20	019300	10693	EPA THIRTY-DAY EXTENSION NOTIFICATION FOR THE INTERIM CORRECTIVE MEASURES IMPLEMENTATION/REMEDIAL ACTION IMPLEMENTATION	MARTHA BERRY	BRIAN T. HENNESSEY	CORRESPONDENCE	1
+019304	01/22/20	019304	10693	SCDHEC CONCURRENCE ON THE LETTER, HENNESSEY TO KEISLER AND POPE, COMPLETION OF OPERATIONAL CLOSURE OF TANKS 5 AND 6 DATED DECEMBER 19, 2013	VAN KEISLER	BRIAN T. HENNESSEY	CORRESPONDENCE	1
+019308	11/06/20	SRR-CWDA-2013-	10693	REQUEST TO REMOVE TANKS 241-918F AND 241-919F FROM CONSTRUCTION PERMIT NO. 71, 424-IW:F AND H-AREA HIGH LEVEL RADIOACTIVE WASTE TANK FARMS	SRR		SUPPORTING DOCUMENT	3
+019309	01/27/20	SRR-CWDA-2014-	10693	REQUEST TO REMOVE TANKS 241-918F AND 241-919F FROM CONSTRUCTION PERMIT No. 17,424-IW: F AND H AREA HIGH LEVEL RADIOACTIVE WASTE TANK FARMS	SRR		SUPPORTING DOCUMENT	3
+019321	01/23/20	019321	10693	EPA CONCURRENCE ON THE LETTER HENNESSEY TO KEISLER AND POPE COMPLETION OF OPERATIONAL CLOSURE OF TANKS 5 AND 6 DATED DECEMBER 19 2013	ROBERT H POPE	BRIAN T. HENNESSEY	CORRESPONDENCE	1
+019327	02/26/20	WDPD-14-28	10693	DOE SUBMITTAL OF THE SAVANNAH RIVER SITE LIQUID WASTE SYSTEM PLAN INPUT AND ASSUMPTIONS	JEAN M. RIDLEY	ROBERT H. POPE/SHELLY WILSON	CORRESPONDENCE	4
+019340	02/18/20	019340	10693	EPA CONDITIONAL APPROVAL OF THE INTERIM CORRECTIVE MEASURES IMPLEMENTATION/REMEDIAL ACTION IMPLEMENTATION PLAN ICMI/RAIP FOR THE F	MARHTA BERRY	BRIAN T. HENNESSEY	CORRESPONDENCE	1
+019348	03/05/20	WDPD-14-27	10693	DOE SUBMITTAL OF THE CALENDAR YEAR CY 2013 ANNUAL REPORT STATUS OF F/H AREA RADIOACTIVE LIQUID WASTE TANKS BEING REMOVED FROM SERVICE	BRIAN T. HENNESSEY	ROBERT H. POPE VAN KEISLER	CORRESPONDENCE	2
+019351	03/01/20	SRR-ESH-2014-00	10693	CALENDAR YEAR CY 2013 ANNUAL REPORT STATUS OF F/H AREA RADIOACTIVE LIQUID WASTE TANKS BEING REMOVED FROM SERVICE	SRR		SUPPORTING DOCUMENT	51

ARF Index 580

Catalog Num	Date	Doc Number	Track #	Title	Author	Addressee	Doc Type	#of Pages
†-019353	03/05/20	SRR-CWDA-2013-	10693	FACT SHEET FOR THE INTERIM REMEDIAL ACTION FOR F-AREA TANK FARM FTF STABILIZED WASTE TANKS 17 THROUGH 20	LAMESHA PRESSLEY		SUPPORTING DOCUMENT	2
†-019392	03/26/20	WDPD-14-35	10693	DOE SUBMITTAL OF THE EXPLANATION OF SIGNIFICANT DIFFERENCE ESD FOR INCORPORATING TANKS 5 AND 6 INTO THE REVISION 1 INTERIM RECORD OF DECISION	BRIAN T. HENNESSEY	ROBERT H. POPE SUSAN B. FULMER	CORRESPONDENCE	2
†-019393	03/01/20	SRR-CWDA-2014-REV 0	10693	EXPLANATION OF SIGNIFICANT DIFFERENCE ESD FOR INCORPORATING TANKS 5 AND 6 INTO THE REVISION 1 INTERIM RECORD OF DECISION REMEDIAL ALTERNATIVE	SRR		SUPPORTING DOCUMENT	15
†-019394	03/26/20	WDPD-14-34	10693	DOE SUBMITTAL OF THE INTERIM CORRECTIVE MEASURES IMPLEMENTATION / REMEDIAL ACTION IMPLEMENTATION PLAN ICMI/RAIP FOR THE F AREA TANK	BRIAN T. HENNESSEY	ROBERT H. POPE SUSAN B. FULMER	CORRESPONDENCE	2
†-019395	12/01/20	SRR-CWDA-2013-REV 1	10693	INTERIM CORRECTIVE MEASURES IMPLEMENTATION / REMEDIAL ACTION IMPLEMENTATION PLAN ICMI/RAIP FOR THE F AREA TANK FARM WASTE TANKS 17 THROUGH	SRR		SUPPORTING DOCUMENT	27
†-019562	05/08/20	019562	10693	SCDHEC APPROVAL OF THE 2013 ANNUAL GROUNDWATER MONITORING REPORT FOR THE F AND H AREA RADIOACTIVE LIQUID WASTE TANK FARMS U	SUSAN B. FULMER	PATRICIA M. ALLEN	CORRESPONDENCE	1
†-019570	04/02/20	019570	10693	SCDHEC LETTER REGARDING CLOSURE AND REMOVAL OF TANKS 18 AND 19 FROM CONSTRUCTION PERMIT NO. 17, 424-1W F AND H AREA THIGH LEVE RADIOACTIVE	JEFFREY P. deBESSONET	VICTOR A. FRANKLIN	CORRESPONDENCE	2
†-019571	03/14/20	019571	10693	SCDHEC LETTER RE: REQUEST TO REMOVE TANKS 241-918F AND 241-919F FROM CONSTRUCTION PERMIT NO. 17, 424-1W: F AND H AREA HIGH LEVEL RADIOACTIVE	JOSHUA C. YON	VICTOR A. FRANKLIN	CORRESPONDENCE	1
†-019580	03/19/20	019580	10693	THE SAVANNAH RIVER SITE ENVIRONMENTAL BULLETIN FOR THE NOTICE OF AVAILABILITY FOR THE FACT SHEET AVAILABLE FOR THE F AREA TANK FARM STABILIZED	SRNS		COMMUNITY INVOLVEMENT	2
†-019582	05/19/20	WDPD-14-42	10693	DOE SUBMITTAL OF THE NOTIFICATION OF THE INTERIM REMEDIAL ACTION COMPLETION FOR F AREA TANK FARM WASTE TANKS 17 THROUGH 20 CERCLIS NUMBER 23	BRIAN T. HENNESSEY	ROBERT H. POPE SUSAN B. FULMER	CORRESPONDENCE	2
†-019588	04/30/20	019588	10693	THE ENVIRONMENTAL BULLETIN FROM THE SAVANNAH RIVER SITE FOR THE NOTICE OF AVAILABILITY FOR THE INTERM RECORD OF DECISION FOR THE F-AREA TANK	SRNS		COMMUNITY INVOLVEMENT	2
†-019590	09/23/20	019590	10693	THE SAVANNAH RIVER SITE ENVIRONMENTAL BULLETIN FOR THE NOTICE OF AVAILABILITY FOR THE EXPLANATION OF SIGNIFICANT DIFFERENCE FOR	SRNS		COMMUNITY INVOLVEMENT	3
†-019596	08/14/20	019596	10693	THE ENVIRONMENTAL BULLETIN FROM THE SAVANNAH RIVER SITE FOR THE INTERIM ACTION STATEMENT OF BASIS/PROPOSED PLAN F-AREA TANK FARM WASTE	SRNS		COMMUNITY INVOLVEMENT	2
†-019601	03/28/20	SRR-ESH-2014-0C	10693	2013 ANNUAL GROUNDWATER MONITORING REPORT FOR THE F AND H AREA RADIOACTIVE LIQUID WASTE TANK FARMS U	SRR	SUSAN FULMER	CORRESPONDENCE	3
†-019606	03/09/20	019606	10693	THE ENVIRONMENTAL BULLETIN FROM THE SAVANNAH RIVER SITE FOR THE ACTION MEMORANDUM AND RESPONSIVENESS SUMMARY ISSUED FOR THE C AREA	SRNS		COMMUNITY INVOLVEMENT	2

ARF Index 580

Catalog Num	Date	Doc Number	Track #	Title	Author	Addressee	Doc Type	#of Pages
+019607	05/21/20	019607	10693	SCDHEC COMMENTS ON THE EXPLANATION OF SIGNIFICANT DIFFERENCE ESD FOR INCORPORATING TANKS 5 AND 6 INTO THE REVISION 1 INTERIM RECORD	SUSAN B. FULMER	BRIAN T. HENNESSEY	CORRESPONDENCE	2
+019634	10/31/20	019364	10693	THE ENVIRONMENTAL BULLETIN FROM THE SAVANNAH RIVER SITE INDUSTRIAL WASTEWATER CLOSURE MODULE FOR THE LIQUID WASTE TANKS 18 AND 19 F	SRNS		COMMUNITY INVOLVEMENT	2
+019641	05/27/20	019641	10693	EPA APPROVAL OF THE EXPLANATION OF SIGNIFICANT DIFFERENCES ESD FOR INCORPORATING TANKS 5 AND 6 INTO THE REVISION 1 INTERIM RECORD OF DECISION	MARTHA BERRY	BRIAN T. HENNESSEY	CORRESPONDENCE	1
+019649	06/02/20	019649	10693	EPA COMMENTS ON THE 2013 ANNUAL GROUNDWATER MONITORING REPORT (REPORT) FOR THE F AND H AREA RADIOACTIVE LIQUID WASTE TANK FARMS,	MARTHA BERRY	PATRICIA ALLEN	CORRESPONDENCE	3
+019758	08/06/20	WDPD-14-65	10693	DOE SUBMITTAL OF THE U S DEPARTMENT OF ENERGY SIGNED EXPLANATION OF SIGNIFICANT DIFFERENCE ESD FOR INCORPORATING TANKS 5 AND 6 INTO THE REVISION	BRIAN T. HENNESSEY	ROBERT H. POPE SUSAN B. FULMER	CORRESPONDENCE	2
+019759	06/30/20	SRR-CWDA-2014-REV 1	10693	DOE SIGNED EXPLANATION OF SIGNIFICANT DIFFERENCE ESD FOR INCORPORATING TANKS 5 AND 6 INTO THE REVISION 1 INTERIM RECORD OF DECISION	SRR		SUPPORTING DOCUMENT	15
+019786	08/21/20	019786	10693	SCDHEC SUBMITTAL OF THE THREE PARTY SIGNED EXPLANATION OF SIGNIFICANT DIFFERENCE ESD FOR INCORPORATING TANKS 5 AND 6 INTO THE REVISION 1	SUSAN B. FULMER	BRIAN T. HENNESSEY	CORRESPONDENCE	1
+019787	06/30/20	SRR-CWDA-2014-REV 1	10693	THREE PARTY SIGNED EXPLANATION OF SIGNIFICANT DIFFERENCE ESD FOR INCORPORATING TANKS 5 AND 6 INTO THE REVISION 1 INTERIM RECORD DECISION	SRR	243	RECORD OF DECISION	15
+019809	09/11/20	SRR-CWDA-2014-	10693	THE SAVANNAH RIVER SITE ENVIRONMENTAL BULLETIN FOR THE NOTICE OF AVAILABILITY FOR THE EXPLANATION OF SIGNIFICANT DIFFERENCE FOR	SRR	243	COMMUNITY INVOLVEMENT	3
+019817	09/18/20	019817	10693	EPA CONCURRENCE ON THE INTERIM REMEDIAL ACTION COMPLETION FOR F AREA TANK FARM WASTE TANKS 17 THROUGH 20	ARTHUR COLLINS	BRIAN T. HENNESSEY	CORRESPONDENCE	1
+019820	08/14/20	019820	10693	EPA SUBMITTAL OF THE EXPLANATION OF SIGNIFICANT DIFFERENCE ESD FOR INCORPORATING TANKS 5 AND 6 INTO THE REVISION 1 INTERIM RECORD OF DECISION	MARTHA BERRY	SUSAN B. FULMER	CORRESPONDENCE	2
+019822	09/17/20	WDPD-14-15	10693	DOE SUBMITTAL OF THE THREE PARTY SIGNED EXPLANATION OF SIGNIFICANT DIFFERENCE ESD FOR INCORPORATING TANKS 5 AND 6 INTO THE REVISION 1	BRIAN T. HENNESSEY	ROBERT H. POPE SUSAN B. FULMER	CORRESPONDENCE	2
+019881	11/06/20	019881	10693	SCDHEC SUBMITTAL OF SAVANNAH RIVER SITE - SC1 890 008 989 FINAL PERMIT DECISION FOR F AREA TANK FARM WASTE TANKS 5 AND 6	DAVID M SCATURO	KEVIN M KOSTELNIK	CORRESPONDENCE	8
+019948	09/09/20	019948	10693	SCDHEC APPROVAL RE: SAVANNAH RIVER SITE INDUSTRIAL TANKS 5 AND 6 FINAL CONFIGURATION REPORT FOR F TANK FARM SRR-CWDA-2014-00020	JEFFREY P DEBESSONET	VICTOR FRANKLIN	CORRESPONDENCE	1
+019949	05/01/20	019949	10693	EPA COMMENTS ON THE TANKS 5 AND 6 FINAL CONFIGURATION REPORT FCR FOR F TANK FARM AT THE SAVANNAH RIVER SITE SRR-CWDA-2014-00020 REVISION	MARTH BERRY	JOEL CANTRELL	CORRESPONDENCE	3

ARF Index 580

Catalog Num	Date	Doc Number	Track #	Title	Author	Addressee	Doc Type	#of Pages
+019950	05/10/20	SRR-CWDA-2014-	10693	REQUEST TO REMOVE TANKS 241-905F AND 241-906F FROM CONSTRUCTION PERMIT No. 17, 424-IW: F AND H AREA HIGH LEVEL RADIOACTIVE WASTE TANK FARMS	SRR	JOSH YON	CORRESPONDENCE	3
+019951	04/03/20	SRR-CWDA-2014-	10693	TRANSMITTAL OF THE TANKS 5 AND 6 FINAL CONFIGURATION REPORT FOR F TANK FARM AT THE SAVANNAH RIVER SITE SRR-CWDA-2014-00020 REVISION	SRR		CORRESPONDENCE	2
+019952	03/30/20	SRR-CWDA-2014- REV. A	10693	TANKS 5 AND 6 FINAL CONFIGURATION REPORT FOR F TANK FARM AT THE SAVANNAH RIVER SITE SRR-CWDA-2014-00020 REVISION A MARCH 2014	SRR		SUPPORTING DOCUMENT	27
+019967	07/28/20	019967	10693	TRANSMITTAL OF THE TANKS 5 AND 6 FINAL CONFIGURATION REPORT FOR F TANK FARM AT THE SAVANNAH RIVER SITE SRR-CWDA-2014-00020 REVISION	VICTOR A. FRANKLIN	JEFFREY P deBESSONET	CORRESPONDENCE	2
+019968	07/28/20	SRR-CWDA-2014- REV 1	10693	TANKS 5 AND 6 FINAL CONFIGURATION REPORT FOR F TANK FARM AT THE SAVANNAH RIVER SITE - COMMENT RESPONSE	SRR		SUPPORTING DOCUMENT	6
+019969	07/28/20	SRR-CWDA-2014- REV 0	10693	TANKS 5 AND 6 FINAL CONFIGURATION REPORT FOR F TANK FARM AT THE SAVANNAH RIVER SITE JULY 2014 SRR-CWDA-2014-00020 REVISION 0	SRR		SUPPORTING DOCUMENT	26
+019992	12/18/20	019992	10693	SCDHEC APPROVAL RE: REQUEST TO REMOVE TANKS 241-905F AND 241-906F FROM CONSTRUCTION PERMIT No. 17, 424-IW: F AND H AREA HIGH LEVEL RADIOACTIVE	JOSHUA C. YON	VICTOR A FRANKLIN	CORRESPONDENCE	1
+019993	12/19/20	019993	10693	SCDHEC APPROVAL RE: (1) LETTER VICTOR A FRANKLIN SRR TO JOSH YON SCDHEC REQUEST TO REMOVE TANKS 241-905F AND 241-906F FROM CONSTRUCTION	JEFFREY P. deBESSONET	VICTOR A. FRANKLIN	CORRESPONDENCE	2
+020035	02/10/20	020035	10693	STATEMENT OF PARTIAL RESOLUTION OF DISPUTE CONCERNING EXTENSION OF FEDERAL FACILITY AGREEMENT FFA CLOSURE DATE	DISPUTE RESOLUTION COMMITTEE		CORRESPONDENCE	1
+020062	03/03/20	WDPD-15-33	10693	DOE SUBMITTAL OF THE CALENDAR YEAR CY 2014 ANNUAL REPORT STATUS OF F/H AREA RADIOACTIVE LIQUID WASTE TANKS BEING REMOVED FROM SERVICE	BRIAN T. HENNESSEY	ROBERT H. POPE	CORRESPONDENCE	2
+020063	03/03/20	WDPD-15-32	10693	DOE SUBMITTAL OF THE CALENDAR YEAR CY 2014 ANNUAL REPORT STATUS OF F/H AREA RADIOACTIVE LIQUID WASTE TANKS BEING REMOVED FROM SERVICE	BRIAN T. HENNESSEY	SUSAN B. FULMER	CORRESPONDENCE	2
+020064	03/30/20	SRR-ESH-2015-00 Rev 0	10693	CY2014 ANNUAL REPORT STATUS OF F/H AREA RADIOACTIVE LIQUID WASTE TANKS BEING REMOVED FROM SERVICE SRR-ESH-2015-00009 MARCH 2015	SRR		SUPPORTING DOCUMENT	28
+020108	04/16/20	020108	10693	SCDHEC CONCURRENCE OF THE CALENDAR YEAR CY 2014 ANNUAL REPORT STATUS OF F/H AREA RADIOACTIVE LIQUID WASTE TANKS BEING REMOVED	SUSAN B. FULMER	BRIAN T. HENNESSEY	CORRESPONDENCE	1
+020109	04/08/20	020109	10693	STATEMENT CONCERNING RESOLUTION OF DISPUTE FOR EXTENSION OF FEDERAL FACILITY AGREEMENT FFA CLOSURE DATE	SENIOR EXECUTIVE COMMITTEE		CORRESPONDENCE	1
+020177	04/27/20	020177	10693	STATEMENT OF RESOLUTION OF DISPUTE CONCERNING EXTENSION OF FEDERAL FACILITY AGREEMENT FFA CLOSURE DATE	SENIOR EXECUTIVE COMMITTEE		CORRESPONDENCE	2

ARF Index 580

Catalog Num	Date	Doc Number	Track #	Title	Author	Addressee	Doc Type	#of Pages
+020178	04/27/20	WDPD-15-39	10693	DOE SUBMITTAL OF THE NOTIFICATION OF THE INTERIM REMEDIAL ACTION COMPLETION FOR F AREA TANK FARM WASTE TANKS 5 AND 6 CERCLIS NUMBER 23	BRIAN T. HENNESSEY	ROBERT H. POPE SUSAN B. FULMER	CORRESPONDENCE	2
+020238	03/31/20	SRR-ESH-2015-00	10693	2014 ANNUAL GROUNDWATER MONITORING REPORT FOR THE F AND H AREA RADIOACTIVE LIQUID WASTE TANK FARMS (U)	PATRICIAL M. ALLEN	SUSAN B. FULMER	CORRESPONDENCE	3
+020239	03/30/20	SRNS-RP-2015-00 REV 0	10693	2014 ANNUAL GROUNDWATER MONITORING REPORT FOR THE F AND H AREA RADIOACTIVE LIQUID WASTE TANK FORMS (U) CERCLIS NUMBER 23 AND 89	SRNS		SUPPORTING DOCUMENT	68
+020243	05/15/20	020243	10693	SCDHEC COMMENTS ON THE 2014 ANNUAL GROUNDWATER MONITORING REPORT FOR THE F AND H AREA RADIOACTIVE LIQUID WASTE TANK FARMS U	SUSAN B. FULMER	BRIAN T. HENNESSEY	CORRESPONDENCE	2
+020249	05/19/20	IACD-15-147	10693	DOE SUBMITTAL OF THE FEDERAL FACILITY AGREEMENT FFA MINOR MODIFICATION TO INCORPORATE STATEMENTS OF DISPUTE RESOLUTION CONCERNING	BRIAN T. HENNESSEY	ROBERT H. POPE SUSAN B. FULMER	CORRESPONDENCE	6
+020259	05/21/20	020259	10693	SCDHEC TRANSMITTAL OF THE SIGNED FEDERAL FACILITY AGREEMENT FFA MINOR MODIFICATION TO INCORPORATE STATEMENTS OF DISPUTE RESOLUTION	SUSAN B. FULMER	ROBERT H. POPE	CORRESPONDENCE	5
+020261	05/19/20	020261	10693	EPA COMMENTS ON THE 2014 ANNUAL GROUNDWATER MONITORING REPORT FOR THE F AND H AREA RADIOACTIVE LIQUID WASTE TANK FARMS U	MARTHA BERRY	BRIAN T. HENNESSEY	CORRESPONDENCE	2
+020293	04/28/20	020293	10693	EPA CONCURRENCE FOR THE INTERIM REMEDIAL ACTION COMPLETION FOR F AREA TANK FARM WASTE TANKS 5F AND 6F CERCLIS NUMBER 23	DON RIGGER	BRIAN T. HENNESSEY	CORRESPONDENCE	2
+020297	06/08/20	020297	10693	EPA SUBMITTAL OF THE SIGNED FEDERAL FACILITY AGREEMENT FFA MINOR MODIFICATION TO INCORPORATE STATEMENTS OF DISPUTE RESOLUTION	BRIAN T. HENNESSEY	ROBERT H. POPE SUSAN B. FULMER	SUPPORTING DOCUMENT	4
+020520	02/18/20	WDPD-16-20	10693	DOE SUBMITTAL OF THE CALENDAR YEAR 2016 NEED FOR CONTINUED USAGE OF HIGH LEVEL WASTE TANKS POST COMPLETION OF BULK WASTE REMOVAL EFFORTS	BRIAN T. HENNESSEY	ROBERT H. POPE SUSAN B. FULMER	CORRESPONDENCE	3
+020522	11/04/20	SRR-LWP-2015-00	10693	WASTE TREATMENT PLANNING REUSE OF TANK PREVIOUSLY DECLARED BWRE COMPLETE	SRR		SUPPORTING DOCUMENT	12
+020523	12/09/20	SRR-LWP-2015-00	10693	CY2016 WASTE TANK TREATMENT PLANNING	SRR		SUPPORTING DOCUMENT	2
+020530	02/25/20	WDPD-16-26	10693	DOE SUBMITTAL OF THE CALENDAR YEAR CY 2015 ANNUAL REPORT STATUS OF F/H AREA RADIOACTIVE LIQUID WASTE TANKS BEING REMOVED FROM SERVICE	BRIAN T. HENNESSEY	ROBERT H. POPE SUSAN B. FULMER	CORRESPONDENCE	2
+020531	03/30/20	SRR-ESH-2016-00	10693	CY2015 ANNUAL REPORT STATUS OF F/H AREA RADIOACTIVE LIQUID WASTE TANKS BEING REMOVED FROM SERVICE	SRR		SUPPORTING DOCUMENT	97
+020532	02/25/20	020532	10693	EPA APPROVAL OF THE CALENDAR YEAR 2016 NEED FOR CONTINUED USAGE OF HIGH LEVEL WASTE TANKS POST COMPLETION OF BULK WASTE REMOVAL EFFORTS:	JON RICHARDS	BRIAN T. HENNESSEY	CORRESPONDENCE	1

ARF Index 580

Catalog Num	Date	Doc Number	Track #	Title	Author	Addressee	Doc Type	#of Pages
+020701	03/30/20	SRNS-RP-2016-0C REV 0	10693	2015 ANNUAL GROUNDWATER MONITORING REPORT FOR THE F AND H AREA RADIOACTIVE LIQUID WASTE TANK FARMS U CERCLIS NUMBER 23 & 89	SRNS		SUPPORTING DOCUMENT	73
+020704	05/11/20	020704	10693	SCDHEC COMMENTS ON THE 2015 ANNUAL GROUNDWATER MONITORING FOR THE F AND H AREA RADIOACTIVE LIQUID WASTE TANK FARMS U CERCLIS	SUSAN B. FULMER	BRIAN T. HENNESSEY	CORRESPONDENCE	2
+020791	08/08/20	WDPD-16-57	10693	DOE SUBMITTAL OF THE REQUEST FOR MINOR MODIFICATION CONCERNING BULK WASTE REMOVAL EFFORTS APPLICABILITY CERCLIS NUMBERS 23 AND 89	BRIAN T. HENNESSEY	ROBERT H. POPE SUSAN B. FULMER	CORRESPONDENCE	13
+020801	04/04/20	020801	10693	MONITORING OF CLOSED WASTE TANKS FOR H-AREA TANK FARM AND F-AREA TANK FARM (2016) WORK ORDER NUMBER 01482179 01	SRNS		SUPPORTING DOCUMENT	38
+020802	04/14/20	020802	10693	MONITORING OF CLOSED WASTE TANKS FOR F-AREA TANK FARM (2014) WORKING ORDER NUMBER 01309306 01	SRNS		SUPPORTING DOCUMENT	35
+020803	06/07/20	020803	10693	MONITORING OF CLOSED WASTE TANKS FOR F-AREA TANK FARM (2013) WORKING ORDER NUMBER 01288365 01	SRNS		SUPPORTING DOCUMENT	28
+020804	03/31/20	020804	10693	MONITORING OF CLOSED WASTE TANKS FOR H-AREA TANK FARM AND F-AREA TANK FARM (2015) WORK ORDER NUMBER 01403045 01	SRNS		SUPPORTING DOCUMENT	
+020984	02/01/20	SRR-CWDA-2017- REV 0	10693	CONSOLIDATED GENERAL CLOSURE PLAN FOR F-AREA AND H-AREA WASTE TANK SYSTEMS (SRR-CWDA-2017-00015, REV. 0)	SRR		SUPPORTING DOCUMENT	127
+020985	02/27/20	SRNS-J2000-2017	10693	READING ROOM CONSOLIDATED GENERAL CLOSURE PLAN FOR F-AREA AND H-AREA WASTE TANK SYSTEMS (SRR-CWDA-2017-00015, REV. 0)	SRR	USC-AIKEN,USC	CORRESPONDENCE	172
+020986	03/01/20	020986	10693	THE SAVANNAH RIVER SITES ENVIRONMENTAL BULLETIN FOR THE CONSOLIDATED GENERAL CLOSURE PLAN FOR THE F-AREA AND H-AREA WASTE TANK SYSTEMS	SRS		COMMUNITY INVOLVEMENT	2
+020989	03/01/20	WDPD-17-20	10693	DOE SUBMITTAL OF THE CALENDAR YEAR CY 2016 ANNUAL REPORT STATUS OF THE F/H AREA RADIOACTIVE LIQUID WASTE TANKS BEING REMOVED	BRIAN T. HENNESSEY	ROBERT H. POPE SUSAN B. FULMER	CORRESPONDENCE	2
+020990	03/01/20	SRR-ESH-2017-0C	10693	CY2016 ANNUAL REPORT STATUS OF F/H AREA RADIOACTIVE LIQUID WASTE TANKS BEING REMOVED FROM SERVICE SRR-ESH-2017-00009 MARCH 2017	SRR		SUPPORTING DOCUMENT	113
+021011	04/13/20	021011	10693	SCDHEC APPROVAL OF THE CALENDAR YEAR (CY) 2016 ANNUAL REPORT STATUS OF F/H AREA RADIOACTIVE LIQUID WASTE TANKS BEING REMOVED FROM SERVICE,	SUSAN B. FULMER	BRIAN T. HENNESSEY	CORRESPONDENCE	1
+021129	05/01/20	021129	10693	EPA COMMENTS ON THE 2016 GROUNDWATER MONITORING REPORT FOR F-AREA AND H-AREA RADIOACTIVE LIQUID WASTE TANK FARMS	JON RICHARDS	BRIAN T. HENNESSEY	CORRESPONDENCE	2
+021130	03/31/20	SRR-ESH-2017-0C	10693	SRR SUBMITTAL OF THE 2016 ANNUAL GROUNDWATER MONITORING REPORT FOR THE F- AND H- AREA RADIOACTIVE LIQUID WASTE TANK FARMS	PATRICIA M. ALLEN	SUSAN B. FULMER	CORRESPONDENCE	2

ARF Index 580

Catalog Num	Date	Doc Number	Track #	Title	Author	Addressee	Doc Type	#of Pages
+021131	03/30/20	SRNS-RP-2017-00	10693	2016 ANNUAL GROUNDWATER MONITORING REPORT FOR THE F- AND H-AREA RADIOACTIVE LIQUID WASTE TANK FARMS U SRNS-RP-2017-00073, REVISION 0, MARCH	SRNS		SUPPORTING DOCUMENT	83
+021154	05/12/20	021154	10693	SCDHEC APPROVAL OF THE 2016 ANNUAL GROUNDWATER MONITORING REPORT FOR THE F- AND H-AREA RADIOACTIVE LIQUID WASTE TANK FARMS, SCDHEC APPROVAL OF THE CONSOLIDATED GENERAL CLOSURE PLAN FOR F AREA AND H AREA WASTE TANK SYSTEMS, SRR-CWDA-2017-00015, REVISION 1 APRIL 2017	SUSAN B. FULMER	BRIAN T. HENNESSEY	CORRESPONDENCE	1
+021187	05/22/20	SRR-OS-2017-000	10693	SCDHEC APPROVAL OF THE CONSOLIDATED GENERAL CLOSURE PLAN FOR F AREA AND H AREA WASTE TANK SYSTEMS, SRR-CWDA-2017-00015, REVISION 1 APRIL 2017	JEFFREY P. DeBESSONET	J. KENT FORTENBERRY	CORRESPONDENCE	2
+021194	04/25/20	SRR-CWDA-2017-	10693	CONSOLIDATED GENERAL CLOSURE PLAN FOR F AREA AND H AREA WASTE TANK SYSTEMS SRR-CWDA-2017-00015 REVISION 1 APRIL 2017	SRR		CORRESPONDENCE	2
+021195	04/01/20	SRR-CWDA-2017- REV 1	10693	CONSOLIDATED GENERAL CLOSURE PLAN FOR F AREA AND H AREA WASTE TANK SYSTEMS APRIL 2017	SRR		CORRESPONDENCE	129
+021196	04/12/20	SRR-CWDA-2017-	10693	COMMENT RESPONSE MATRIX FOR SCDHEC COMMENTS ON SAVANNAH RIVER REMEDIATION SRR CONSOLIDATED GENERAL CLOSURE PLAN FOR F AREA AND H AREA	SRR		SUPPORTING DOCUMENT	7
+021257	10/02/20	021257	10693	EPA APPROVAL OF THE EXTENSION REQUEST FOR 9/30/17 - HIGH LEVEL WASTE TANKS BULK WASTE REMOVAL EFFORTS BWRE AND OPERATIONAL CLOSURE	JON RICHARDS	BRIAN T. HENNESSEY	CORRESPONDENCE	1
+021258	09/27/20	WDPD-17-46	10693	DOE SUBMITTAL OF THE EXTENSION REQUEST FOR 9/30/17 - HIGH LEVEL WASTE TANKS BULK WASTE REMOVAL EFFORTS BWRE AND OPERATIONAL CLOSURE	BRIAN T. HENNESSEY	ROBERT H. POPE SUSAN B. FULMER	CORRESPONDENCE	2
+021271	10/02/20	021271	10693	SCDHEC APPROVAL OF THE EXTENSION REQUEST FOR 9/30/17 - HIGH LEVEL WASTE TANKS BULK WASTE REMOVAL EFFORTS BWRE AND OPERATIONAL CLOSURE	SUSAN B. FULMER	BRIAN T. HENNESSEY	CORRESPONDENCE	1
+021303	11/16/20	WDPD-18-05	10693	DOE SUBMITTAL OF THREE-PARTY SIGNED SUSPENSION AGREEMENT AND THREE-PARTY SIGNED MINOR MODIFICATION FOR THE HIGH LEVEL WASTE TANKS BULK	BRIAN T. HENNESSEY	JON RICHARDS SUSAN B. FULMER	CORRESPONDENCE	54
+021423	03/01/20	WDPD-18-14	10693	DOE SUBMITTAL OF THE CALENDAR YEAR CY 2017 ANNUAL REPORT STATUS OF F/H AREA RADIOACTIVE LIQUID WASTE TANKS BEING REMOVED FROM SERVICE	BRIAN T.HENNESSEY	JON RICHARDS SUSAN B.	CORRESPONDENCE	2
+021424	03/01/20	SRR-ESH-2018-00	10693	CALENDAR YEAR CY 2017 ANNUAL REPORT STATUS OF F/H AREA RADIOACTIVE LIQUID WASTE TANKS BEING REMOVED FROM SERVICE SRR-ESH-2018-00007 MARCH	SRR		SUPPORTING DOCUMENT	76
+021463	04/09/20	SRR-OS-2018-000	10693	SCDHEC APPROVAL OF THE CONTINUED USAGE OF HIGH LEVEL WASTE TANK 7F, SEMS NUMBER: 23 DATED APRIL 3 2018 AND RECEIVED APRIL 5 2018	SUSAN B. FULMER	BRIAN T. HENNESSEY	CORRESPONDENCE	1
+021468	04/03/20	WDPD-18-21	10693	DOE SUBMITTAL OF THE CONTINUED USAGE OF HIGH-LEVEL WASTE TANK 7F, SEMS NUMBER: 23	BRIAN T. HENNESSEY	JON RICHARDS SUSAN B.	CORRESPONDENCE	6
+021480	04/13/20	021480	10693	SCDHEC APPROVAL OF THE CALENDAR YEAR (CY) 2017 ANNUAL REPORT STATUS OF F/H AREA RADIOACTIVE LIQUID WASTE TANKS BEING REMOVED FROM SERVICE,	S. Fulmer	B. Hennessey	CORRESPONDENCE	1

ARF Index 580

Catalog Num	Date	Doc Number	Track #	Title	Author	Addressee	Doc Type	#of Pages
+021485	04/25/20	SRR-OS-2018-000	10693	EPA APPROVAL OF THE CONTINUED USE OF HIGH-LEVEL WASTE TANK 7F, SEMS NUMBER: 23 (APRIL 3, 2018)	J. Richards	B. Hennessey	CORRESPONDENCE	1
+021629	05/04/20	021629	10693	SCDHEC COMMENTS ON THE 2017 ANNUAL GROUNDWATER MONITORING REPORT FOR THE F-AREA AND H-AREA READIOACTIVE LIQUID WASTE TANK FARMS	S. Fulmer	P. Allen	CORRESPONDENCE	2
+021632	05/17/20	WDPD-18-29	10693	DOE SUBMITTAL LETTER FOR CONTINUED USAGE OF HIGH-LEVEL WASTE TANK 8F, SEMS NUMBER: 23	B. Hennessey	S. Fulmer J. Richards	CORRESPONDENCE	5
+021641	03/22/20	SRR-ESH-2018-00	10693	SRR SUBMITTAL OF 2017 ANNUAL GROUNDWATER MONITORING REPORT FOR THE F- AND H- AREA RADIOACTIVE LIQUID WASTE TANK FARMS (U)	P. Allen	S. Fulmer	CORRESPONDENCE	2
+021645	05/18/20	021645	10693	EPA COMMENTS ON THE 2017 ANNUAL GROUNDWATER MONITORING REPORT FOR THE F- AND H- AREA RADIOACTIVE LIQUID WASTE TANK FARMS, CERCLIS	J.Richards	B. Henessey	CORRESPONDENCE	2
+021646	05/22/20	021646	10693	EPA APPROVAL OF THE CONTINUED USAGE OF HIGH-LEVEL WASTE TANK 8F, SEMS NUMBER :23 (DATED MAY 17, 2018)	J. Richards	B. Hennessey	CORRESPONDENCE	1
+021659	05/30/20	021659	10693	SCDHEC APPROVAL OF THE CONTINUED USAGE OF HIGH-LEVEL WASTE TANK 8F, SEMS NUMBER: 23 (DATED MAY 17, 2018, AND RECEIVED MAY 21, 2018)	S. Fulmer	B. Hennessey	CORRESPONDENCE	1
+021921	02/01/20	WDPD-19-15	10693	DOE SUBMITTAL OF LIQUID WASTE SYSTEM PLAN REVISION 21 (SEMS NUMBERS: 23 AND 89)	B. HENNESSEY	J. RICHARDS,S. FULMER	CORRESPONDENCE	2
+021922	01/01/20	SRR-LWP-2009-00	10693	SRR LIQUID WASTE SYSTEM PLAN, SRR-LWP-2009-00001, REVISION 21, JANUARY 2019	SRR		SUPPORTING DOCUMENT	62
+021970	03/07/20	WDPD-19-21	10693	DOE SUBMITTAL FOR THE CALENDAR YEAR (CY) 2018 ANNUAL REPORT STATUS OF F/H AREA RADIOACTIVE LIQUID WASTE TANKS BEING REMOVED FROM SERVICE	B. HENNESSEY	J. RICHARDS,S. FULMER	CORRESPONDENCE	2
+021971	03/01/20	SRR-ESH-2019-00	10693	STATUS OF F/H AREA RADIOACTIVE LIQUID WASTE TANKS BEING REMOVED FROM SERVICE CY2018 ANNUAL REPORT (SRR-ESH-2019-00014, REVISION 0, MARCH 2019)	SRR		SUPPORTING DOCUMENT	116
+022010	04/09/20	WDPD-19-27	10693	DOE SUBMITTAL LETTER OF MINOR MODIFICATION FOR THE 2019 SUSPENSION AGREEMENT OF FEDERAL FACILITY AGREEMENT HIGH-LEVEL WASTE TANK	B. HENNESSEY	J. RICHARDS,S. FULMER	CORRESPONDENCE	6
+022147	04/25/20	SRNS-OS-2019-00	10693	EPA APPROVAL AND SIGNATURE FOR THE MINOR MODIFICATION FOR THE 2019 SUSPENSION AGREEMENT OF FFA HIGH-LEVEL WASTE TANK MILESTONES (SEMS 23	J.RICHARDS	B.HENNESSEY	CORRESPONDENCE	5
+022148	04/11/20	SRNS-OS-2019-00	10693	SCDHEC LETTER FOR SIGNATURE MINOR MODIFICATION FOR THE 2019 SUSPENSION AGREEMENT OF FEDERAL FACILITY AGREEMENT HIGH-LEVEL WASTE TANK	S.FULMER	J.RICHARDS	CORRESPONDENCE	1
+022170	03/29/20	SRR-ESH-2019-00	10693	SRR SUBMITTAL OF THE 2018 ANNUAL GROUNDWATER MONITORING REPORT FOR THE F- AND H-AREA RADIOACTIVE LIQUID WASTE TANK FARMS (U)	P. ALLEN	S. FULMER	CORRESPONDENCE	2

ARF Index 580

Catalog Num	Date	Doc Number	Track #	Title	Author	Addressee	Doc Type	#of Pages
†022171	03/01/20	SRNS-RP-2019-0C	10693	2018 ANNUAL GROUNDWATER MONITORING REPORT FOR THE F- AND H-AREA RADIOACTIVE LIQUID WASTE TANK FARMS (U) (SRNS-RP-2019-00097, REVISION 0,	SRNS		SUPPORTING DOCUMENT	76
†022197	05/09/20	SRNS-OS-2019-0C	10693	SCDHEC COMMENTS ON THE 2018 ANNUAL GROUNDWATER MONITORING REPORT FOR THE F-AREA AND H-AREA RADIOACTIVE LIQUID WASTE TANK FARMS	S. FULMER	P. ALLEN	CORRESPONDENCE	2
†022352	09/30/20	IACD-19-147	10693	U.S. DOE SUBMITTAL OF CONTINUED USAGE OF HIGH-LEVEL WASTE TANK 4F, SEMS NUMBER: 23	B. HENNESSEY	J. RICHARDS,S. FULMER	CORRESPONDENCE	5
†022368	10/02/20	SRNS-OS-2019-0C	10693	SCDHEC APPROVAL OF CONTINUED USAGE OF HIGH-LEVEL WASTE TANK 4F, SEMS NUMBER: 23 (DATED SEPTEMBER 30, 2019, AND OCTOBER 1, 2019)	S. FULMER	B. HENNESSEY	CORRESPONDENCE	1
†022405	09/26/20	WDPD-19-48	10693	DOE SUBMITTAL OF THE DISPUTE RESOLUTION AGREEMENT SUPPLEMENTAL TANK CLOSURE ACTIVITY (STCA): EVALUATION OF THE TECHNICAL FEASIBILITY	J. FOLK	M. LINDLER	CORRESPONDENCE	20
†022407	11/04/20	SRNS-OS-2019-0C	10693	EPA COMMENTS ON THE DISPUTE RESOLUTION AGREEMENT SUPPLEMENTAL TANK CLOSURE ACTIVITY [STCA]; EVALUATION OF THE TECHNICAL FEASIBILITY &	J. RICHARDS	B. HENNESSEY	CORRESPONDENCE	3
†022616	03/06/20	WDPD-20-19	10693	DOE SUBMITTAL FOR THE CALENDAR YEAR (CY) 2019 ANNUAL REPORT STATUS OF F/H AREA RADIOACTIVE LIQUID WASTE TANKS BEING REMOVED FROM SERVICE	B. HENNESSEY	S. FULMER,J. RICHARDS	CORRESPONDENCE	2
†022617	03/01/20	SRR-ESH-2020-0C	10693	STATUS OF F/H AREA RADIOACTIVE LIQUID WASTE TANKS BEING REMOVED FROM SERVICE CY2019 ANNUAL REPORT SRR-ESH-2020-00010 REVISION 0	SRR		SUPPORTING DOCUMENT	74
†022677	04/20/20	SRNS-OS-2020-0C	10693	SCDHEC APPROVAL OF THE CALENDAR YEAR (CY) 2019 ANNUAL REPORT STATUS OF F/H AREA RADIOACTIVE LIQUID WASTE TANKS BEING REMOVED FROM SERVICE,	B. HENNESSEY	S. FULMER	CORRESPONDENCE	1
†022688	03/23/20	SRR-ESH-2020-0C	10693	SRR SUBMITTAL FOR THE 2019 ANNUAL GROUNDWATER MONITORING REPORT FOR THE F- AND H-AREA RADIOACTIVE LIQUID WASTE TANK FARMS	SRR		CORRESPONDENCE	2
†022689	03/17/20	SRNS-RP-2020-0C	10693	2019 ANNUAL GROUNDWATER MONITORING REPORT FOR THE F- AND H-AREA RADIOACTIVE LIQUID WASTE TANK FARMS (SRNS-RP-2020-00066, REVISION 0, MARCH	SRNS		SUPPORTING DOCUMENT	75
†022691	05/05/20	SRNS-OS-2020-0C	10693	SCDHEC APPROVAL OF THE 2019 ANNUAL GROUNDWATER MONITORING REPORT FOR THE F- AND H-AREA RADIOACTIVE LIQUID WASTE TANK FARMS (U),	S. FULMER	B. HENNESSEY	CORRESPONDENCE	1
†022756	06/17/20	WDPD-20-31	10693	DOE SUBMITTAL LETTER FOR COMPLETION OF FEDERAL FACILITY AGREEMENT MILESTONE "F-TANK FARM (FTF) DEACTIVATION PLAN" LOCATED IN THE 2019	B. HENNESSEY	J. RICHARDS,S. FULMER	CORRESPONDENCE	2
†022757	05/01/20	SRR-CWDA-2020-	10693	SAVANNAH RIVER SITE F-TANK FARM DEACTIVATION PLAN AND CLOSURE STRATEGY (SRR-CWDA-2020-00037, REVISION 1, MAY 2020) SEMS NUMBER: 23	SRR		SUPPORTING DOCUMENT	155
†022816	07/28/20	WDPD-20-37	10693	DOE SUBMITTAL FOR THE REQUEST FOR CONCURRENCE TO PROCEED TO SAMPLE AND ANALYSIS PHASE OF THE CLOSURE PROCESS FOR F-AREA DIVERSION BOXES	B. HENNESSEY	J. RICHARDS; S. FULMER	CORRESPONDENCE	2

ARF Index 580

Catalog Num	Date	Doc Number	Track #	Title	Author	Addressee	Doc Type	#of Pages
+022817	07/13/20	SRR-CWDA-2020-	10693	SRR PROPOSAL TO CEASE WASTE REMOVAL ACTIVITIES IN F-AREA DIVERSION BOXES 5 AND 6	SRR		SUPPORTING DOCUMENT	97
+022829	07/29/20	SRNS-OS-2020-0C	10693	SCDHEC CONCURRENCE OF THE REQUEST FOR CONCURRENCE TO PROCEED TO SAMPLE AND ANALYSIS PHASE OF THE CLOSURE PROCESS FOR F-AREA	S. FULMER	B. HENNESSEY	CORRESPONDENCE	1
+022832	07/30/20	SRNS-OS-2020-0C	10693	SCDHEC COMMENTS ON THE SAVANNAH RIVER SITE F-AREA TANK FARM DEACTIVATION PLAN AND CLOSURE STRATEGY (SRR-CWDA-2020-00037, REVISION 1, MAY	S. FULMER	B. HENNESSEY	CORRESPONDENCE	2
+022835	08/11/20	SRNS-OS-2020-0C	10693	EPA CONCURRENCE OF THE REQUEST FOR CONCURRENCE TO PROCEED TO SAMPLE AND ANALYSIS PHASE OF THE CLOSURE PROCESS FOR F AREA	R. POPE	B. HENNESSEY	CORRESPONDENCE	2
+022874	03/01/20	SRNS-RP-2018-0C	10693	2017 ANNUAL GROUNDWATER MONITORING REPORT FOR THE F- AND H- AREA RADIOACTIVE LIQUID WASTE TANK FARMS (U) (SRNS-RP-2018-00226, REVISION 0,	SRNS		SUPPORTING DOCUMENT	78
+023048	01/20/20	SRNS-OS-2021-0C	10693	EPA COMMENTS ON THE REVIEW OF THE INDUSTRIAL WASTEWATER CLOSURE MODULE FOR F-AREA DIVERSION BOXES 5 AND 6 F-AREA TANK FARM,	J. RICHARDS	B. HENNESSEY	CORRESPONDENCE	3
+023113	03/02/20	WDPD-21-25	10693	DOE SUBMITTAL LETTER FOR THE CALENDAR YEAR (CY) 2020 ANNUAL REPORT STATUS OF F/H AREA RADIOACTIVE LIQUID WASTE TANKS BEING REMOVED	B. HENNESSEY	J. RICHARDS; S. FULMER	CORRESPONDENCE	2
+023114	03/01/20	SRR-ESH-2021-0C	10693	CALENDAR YEAR (CY) 2020 ANNUAL REPORT STATUS OF F/H AREA RADIOACTIVE LIQUID WASTE TANKS BEING REMOVED FROM SERVICE (SRR-ESH-2021-00012,	SRR		SUPPORTING DOCUMENT	55
023123	03/03/20	SRR-CWDA-2020-	10693	SRR TRANSMITTAL OF THE INDUSTRIAL WASTEWATER CLOSURE MODULE FOR F-AREA DIVERSION BOXES 5 AND 6 F-AREA TANK FARM, SAVANNAH RIVER SITE	SRR		CORRESPONDENCE	2
023127	03/01/20	SRR-ESH-2021-0C	10693	SRR SUBMITTAL FOR THE 2020 ANNUAL GROUNDWATER MONITORING REPORT FOR THE F- AND H- AREA RADIOACTIVE LIQUID WASTE TANK FARMS	P. ALLEN	S. FULMER	CORRESPONDENCE	82
023128	03/01/20	SRNS-RP-2021-0C	10693	2020 ANNUAL GROUNDWATER MONITORING REPORT FOR THE F- AND H-AREA RADIOACTIVE LIQUID WASTE TANK FARMS (U)	SRNS		SUPPORTING DOCUMENT	80
023132	02/01/20	SRR-CWDA-2020-	10693	INDUSTRIAL WASTEWATER CLOSURE MODULE FOR F-AREA DIVERSION BOXES 5 AND 6 F-AREA TANK FARM, SAVANNAH RIVER SITE	SRR		SUPPORTING DOCUMENT	78
023133	02/22/20	SRR-CWDA-2021-	10693	COMMENT RESPONSE MATRIX FOR COMMENTS ON SAVANNAH RIVER REMEDIATION (SRR) INDUSTRIAL WASTEWATER CLOSURE FOR F-AREA DIVERSIO BOXES 5	J. PAVLETICH		SUPPORTING DOCUMENT	20

ARF Index 1307

Catalog Num	Date	Doc Number	Track #	Title	Author	Addressee	Doc Type	#of Pages
+022816	07/28/20	WDPD-20-37	10693	DOE SUBMITTAL FOR THE REQUEST FOR CONCURRENCE TO PROCEED TO SAMPLE AND ANALYSIS PHASE OF THE CLOSURE PROCESS FOR F-AREA DIVERSION BOXES	B. HENNESSEY	J. RICHARDS; S. FULMER	CORRESPONDENCE	2
+022817	07/13/20	SRR-CWDA-2020-	10693	SRR PROPOSAL TO CEASE WASTE REMOVAL ACTIVITIES IN F-AREA DIVERSION BOXES 5 AND 6	SRR		SUPPORTING DOCUMENT	97
+022829	07/29/20	SRNS-OS-2020-00	10693	SCDHEC CONCURRENCE OF THE REQUEST FOR CONCURRENCE TO PROCEED TO SAMPLE AND ANALYSIS PHASE OF THE CLOSURE PROCESS FOR F-AREA	S. FULMER	B. HENNESSEY	CORRESPONDENCE	1
+022835	08/11/20	SRNS-OS-2020-00	10693	EPA CONCURRENCE OF THE REQUEST FOR CONCURRENCE TO PROCEED TO SAMPLE AND ANALYSIS PHASE OF THE CLOSURE PROCESS FOR F AREA	R. POPE	B. HENNESSEY	CORRESPONDENCE	2
+023048	01/20/20	SRNS-OS-2021-00	10693	EPA COMMENTS ON THE REVIEW OF THE INDUSTRIAL WASTEWATER CLOSURE MODULE FOR F-AREA DIVERSION BOXES 5 AND 6 F-AREA TANK FARM,	J. RICHARDS	B. HENNESSEY	CORRESPONDENCE	3
023123	03/03/20	SRR-CWDA-2020-	10693	SRR TRANSMITTAL OF THE INDUSTRIAL WASTEWATER CLOSURE MODULE FOR F-AREA TANK FARM, SAVANNAH RIVER SITE	SRR		CORRESPONDENCE	2
023132	02/01/20	SRR-CWDA-2020-	10693	INDUSTRIAL WASTEWATER CLOSURE MODULE FOR F-AREA DIVERSION BOXES 5 AND 6 F-AREA TANK FARM, SAVANNAH RIVER SITE	SRR		SUPPORTING DOCUMENT	78
023133	02/22/20	SRR-CWDA-2021-	10693	COMMENT RESPONSE MATRIX FOR COMMENTS ON SAVANNAH RIVER REMEDIATION (SRR) INDUSTRIAL WASTEWATER CLOSURE FOR F-AREA DIVERSIO BOXES 5	J. PAVLETICH		SUPPORTING DOCUMENT	20

ARF Index 1308

Catalog Num	Date	Doc Number	Track #	Title	Author	Addressee	Doc Type	#of Pages
+022816	07/28/20	WDPD-20-37	10693	DOE SUBMITTAL FOR THE REQUEST FOR CONCURRENCE TO PROCEED TO SAMPLE AND ANALYSIS PHASE OF THE CLOSURE PROCESS FOR F-AREA DIVERSION BOXES	B. HENNESSEY	J. RICHARDS; S. FULMER	CORRESPONDENCE	2
+022817	07/13/20	SRR-CWDA-2020-	10693	SRR PROPOSAL TO CEASE WASTE REMOVAL ACTIVITIES IN F-AREA DIVERSION BOXES 5 AND 6	SRR		SUPPORTING DOCUMENT	97
+022829	07/29/20	SRNS-OS-2020-00	10693	SCDHEC CONCURRENCE OF THE REQUEST FOR CONCURRENCE TO PROCEED TO SAMPLE AND ANALYSIS PHASE OF THE CLOSURE PROCESS FOR F-AREA	S. FULMER	B. HENNESSEY	CORRESPONDENCE	1
+022835	08/11/20	SRNS-OS-2020-00	10693	EPA CONCURRENCE OF THE REQUEST FOR CONCURRENCE TO PROCEED TO SAMPLE AND ANALYSIS PHASE OF THE CLOSURE PROCESS FOR F AREA	R. POPE	B. HENNESSEY	CORRESPONDENCE	2
+023048	01/20/20	SRNS-OS-2021-00	10693	EPA COMMENTS ON THE REVIEW OF THE INDUSTRIAL WASTEWATER CLOSURE MODULE FOR F-AREA DIVERSION BOXES 5 AND 6 F-AREA TANK FARM,	J. RICHARDS	B. HENNESSEY	CORRESPONDENCE	3
023123	03/03/20	SRR-CWDA-2020-	10693	SRR TRANSMITTAL OF THE INDUSTRIAL WASTEWATER CLOSURE MODULE FOR F-AREA TANK FARM, SAVANNAH RIVER SITE	SRR		CORRESPONDENCE	2
023132	02/01/20	SRR-CWDA-2020-	10693	INDUSTRIAL WASTEWATER CLOSURE MODULE FOR F-AREA DIVERSION BOXES 5 AND 6 F-AREA TANK FARM, SAVANNAH RIVER SITE	SRR		SUPPORTING DOCUMENT	78
023133	02/22/20	SRR-CWDA-2021-	10693	COMMENT RESPONSE MATRIX FOR COMMENTS ON SAVANNAH RIVER REMEDIATION (SRR) INDUSTRIAL WASTEWATER CLOSURE FOR F-AREA DIVERSIO BOXES 5	J. PAVLETICH		SUPPORTING DOCUMENT	20

SRR-CWDA-2020-00011
Revision 0

**INDUSTRIAL WASTEWATER CLOSURE MODULE FOR
F-AREA DIVERSION BOXES 5 AND 6
F-AREA TANK FARM, SAVANNAH RIVER SITE**

February 2021

Industrial Wastewater Construction Permit No. 17,424-IW

Prepared by: Savannah River Remediation LLC
Waste Disposal Authority
Aiken, SC 29808



Prepared for U.S. Department of Energy Under Contract No. DE-AC09-09SR22505

This page intentionally left blank

TABLE OF CONTENTS

TABLE OF CONTENTS	3
LIST OF FIGURES	5
LIST OF TABLES	6
ACRONYMS	7
EXECUTIVE SUMMARY	9
1.0 INTRODUCTION	11
2.0 FACILITY DESCRIPTION	13
2.1 FDB-5 Design and Construction	15
2.2 FDB-5 Vault Piping	19
2.3 FDB-5 Operational History	21
2.3.1 FDB-5 Decontamination History	21
2.4 FDB-5 Inspections	21
2.5 FDB-6 Design and Construction	25
2.6 FDB-6 Vault Piping	30
2.7 FDB-6 Operational History	31
2.7.1 FDB-6 Leakage and Decontamination History	32
2.8 FDB-6 Inspections	32
3.0 FDB-5 and FDB-6 WASTE REMOVAL	36
3.1 FDB-5 Waste Removal	36
3.2 FDB-6 Waste Removal	36
3.3 Residual Material Volume Estimate	36
3.4 Basis to Proceed to Sampling and Analysis Phase in FDB-5 and FDB-6	36
3.5 Agreement to Proceed to Sampling and Analysis Phase	37
4.0 RESIDUAL MATERIAL CHARACTERIZATION	38
4.1 FDB-5 and FDB-6 Inventory Determination Methodology	38
4.1.1 Inventory Calculation	39
4.1.2 Dry Sludge Concentrations Used for Inventory Calculation	39
4.2 FDB-5 Assigned Inventory	40
4.3 FDB-6 Assigned Inventory	42
4.4 Assigned Inventory Conservatism	44
5.0 PERFORMANCE EVALUATION	46
5.1 FDB-5 and FDB-6 Special Analysis	46
5.2 Assessment Evaluation	46
5.3 Groundwater Evaluation	47
5.3.1 Groundwater Concentrations at the Seep Lines	48
5.3.2 MOP Exposure Dose Analysis	48

5.3.3	MOP Peak Groundwater and All-Pathways Dose at the Stream	53
5.4	RCRA/CERCLA Risk Analysis	53
5.5	F-Tank Farm Interpretation of Results	53
5.6	Conclusions.....	53
6.0	ASSESSMENT OF THE IMPACT OF DEPLOYING ADDITIONAL WASTE REMOVAL TECHNOLOGY	56
6.1	Analysis of Potential Cleaning Technologies	56
6.1.1	Mechanical Cleaning Technologies.....	57
6.1.2	Chemical Cleaning Technologies	57
6.1.3	Vacuum Cleaning Technologies.....	57
6.1.4	Technology Deployment Issues in FDB-5 and FDB-6.....	58
6.2	Estimated Dose Reduction.....	58
6.3	Assessment Conclusion	59
7.0	ANCILLARY STRUCTURE ISOLATION PROCESS AND STABILIZATION STRATEGY	60
7.1	FDB-5 and FDB-6 Isolation Process	60
7.1.1	FDB-5 System Isolation.....	60
7.1.2	FDB-6 System Isolation.....	62
7.2	Additional Diversion Box Systems Requiring Isolation.....	64
7.3	FDB-5 and FDB-6 Stabilization Strategy	65
7.3.1	Grout Option Selection	65
7.3.2	Grout Functions, Requirements, and Formulation.....	65
7.4	Diversion Box Grouting Plan.....	66
7.4.1	FDB-5 Grouting	66
7.4.2	FDB-6 Grouting	67
7.4.3	Equipment Abandoned in the Diversion Boxes.....	67
7.4.4	Transfer Line Grouting	68
8.0	MAINTENANCE AND MONITORING PLANS	69
9.0	CONCLUSIONS.....	70
10.0	REFERENCES	73
APPENDIX A:	FTF WASTE TANK SYSTEMS CLOSURE TRACKING	77

LIST OF FIGURES

Figure 1.0-1: SRS Operational Area Location Map	11
Figure 2.0-1: Layout of the F-Area Tank Farm and Locations of FDB-5 and FDB-6	13
Figure 2.0-2: Layout of the GSA Showing F Area and the FTF	14
Figure 2.1-1: Plan View of FDB-5 and Cell Covers.....	17
Figure 2.1-2: Cross-Sections of FDB-5 Showing the Sump, Leak Detection Box, and Vault Flush Water Valve Box and Piping Inlet.....	18
Figure 2.1-3: View of the FDB-5 Northeast Corner, Flush Water Valve Box, and Vault Access Riser Area. View to Southwest, May 2018.	19
Figure 2.2-1: FDB-5 Waste Transfer Piping System Diagram.....	20
Figure 2.4-1: View Looking Down at the FDB-5 Sump (November 2018).....	22
Figure 2.4-2: Views of the FDB-5 Vault Interior	23
Figure 2.4-3: Close-up View of FDB-5 Northwest floor Area (February 5, 2020).....	24
Figure 2.4-4: Close-up View of FDB-5 Sump Area (February 5, 2020).....	25
Figure 2.5-1: Plan View of FDB-6 and Cross-Sections of the Vault Sump and Underliner Drain System.....	27
Figure 2.5-2: Cross-Section of FDB-6 Showing the Flush Water Valve Box Detail	28
Figure 2.5-3: Plan View of the FDB-6 Cell Cover Slabs and Vault Access Risers	28
Figure 2.5-4: Aerial View of FDB-6 Showing Rain Cover, Cases Covering Vault Access Risers, Stairs to Vault Top, and HEPA System. View to West.....	29
Figure 2.5-5: Close-up View of the FDB-6 Vault Top, Cases Covering Vault Access Risers and Flush Water Valve Box. View to West.....	29
Figure 2.6-1: FDB-6 Transfer Piping System Diagram.....	30
Figure 2.8-1: Views of the FDB-6 Vault Interior	33
Figure 2.8-2: View of the FDB-6 Vault Southwest Corner and Sump (July 2018)	34
Figure 2.8-3: The Material (Salt) Deposit below Nozzle 4 in the Southeast Vault Region (July 2018).....	34
Figure 2.8-4: View of FDB-6 North Region Floor Showing Discarded Plastic beneath a Disconnected Hanford Connector (July 2018)	35
Figure 2.8-5: Close-up of Plastic Piece on FDB-6 Vault Floor (July 2018)	35
Figure 5.3-1 FTF 1-meter and 100-meter PORFLOW Model Evaluation Sectors.....	49
Figure 5.3-2: FDB-5 100-Meter MOP Peak Groundwater Pathway Dose within 10,000 Years for the Five 100-Meter Modeling Sectors.....	51
Figure 5.3-3: FDB-6 100-Meter MOP Peak Groundwater Pathway Dose within 10,000 Years for the Five 100-Meter Modeling Sectors.....	52
Figure 7.1-1: FDB-5 Transfer Lines	61
Figure 7.1-2: FDB-5 Sump and Overflow Drain Lines	62
Figure 7.1-3: FDB-6 Transfer Lines	63
Figure 7.1-4: FDB-6 Sump and Overflow Drain Lines	64
Figure 9.0-1: Views of the FDB-5 Vault Interior	70
Figure 9.0-2: Views of the FDB-6 Vault Interior	71

LIST OF TABLES

Table 2.2-1: Current Status of FDB-5 Waste Transfer Piping System.....20
Table 2.2-2: Additional FDB-5 Vault Piping System Lines.....21
Table 2.6-1: Current Status of FDB-6 Waste Transfer Piping System.....31
Table 2.6-2: Additional FDB-6 Vault Piping System Lines.....31
Table 4.2-1: FDB-5 Assigned Radionuclide Inventory (Decayed to 9/30/2020)41
Table 4.2-2: FDB-5 Assigned Chemical Inventory42
Table 4.3-1: FDB-6 Assigned Radionuclide Inventory (Decayed to 9/30/2020)43
Table 4.3-2: FDB-6 Assigned Chemical Inventory44
Table 5.3-1: 100-Meter MOP Peak Groundwater Pathways Dose by Modeling Sector50
Table 5.6-1: Key Limits from Regulatory Requirements54
Table 5.6-2: Summary Radiological Results for F-Tank Farm54
Table A-1: FTF Waste Tank Systems Removal from Service Tracking Table.....77

ACRONYMS

AEA	Atomic Energy Act
ALARA	As Low As Reasonably Achievable
CERCLA	Comprehensive Environmental Response, Compensation, and Liability Act
CGCP	Consolidated General Closure Plan
CLSM	Controlled Low-Strength Material
CM	Closure Module
CMCOC	Contaminant Migration Constituents of Concern
COC	Constituents of Concern
CTS	Concentrate Transfer System
DB	Diversion Box
DOE	U. S. Department of Energy
EIS	Environmental Impact Statement
EPA	U. S. Environmental Protection Agency
FCR	Final Configuration Report
FDB	F-Area Diversion Box
FFA	Federal Facilities Agreement
FPP	F-Area Pump Pit
FTF	F-Area Tank Farm
GSA	General Separations Area
HEPA	High Efficiency Particulate Air
HTF	H-Area Tank Farm
I.D.	Inside Diameter
IROD	Interim Record of Decision
LDB	Leak Detection Box
LTAD	Low Temperature Aluminum Dissolution
LWTRSAPP	Liquid Waste Tank Residuals Sampling and Analysis Program Plan
LZ	Lower Zone
MCL	Maximum Contaminant Level
MOP	Member of the Public
N/A	Not Applicable
OA	Oxalic Acid
OU	Operable Unit
P&ID	Piping and Instrumentation Diagrams
PA	Performance Assessment
PP	Pump Pit
PRG	Preliminary Remediation Goal
PS	Production Support
RCRA	Resource Conservation and Recovery Act
RFS	Removal from Service
ROD	Record of Decision
RSL	Regional Screening Level
SA	Special Analysis
SCDHEC	South Carolina Department of Health and Environmental Control
SLDR	Sample Location Determination Report

SRS	Savannah River Site
SRR	Savannah River Remediation LLC
TSR	Technical Safety Requirements
UTR	Upper Three Runs
UTRA	Upper Three Runs Aquifer
UZ	Upper Zone
WCS	Waste Characterization System
WTS	Waste Transfer System

EXECUTIVE SUMMARY

The *Consolidated General Closure Plan for F-Area and H-Area Waste Tank Systems* (CGCP) (SRR-CWDA-2017-00015) was prepared to support the future removal from service (RFS) of the F-Area Tank Farm (FTF) and H-Area Tank Farm (HTF) underground radioactive waste tanks and ancillary structures at the Savannah River Site (SRS) that are regulated under the *F and H Area High Level Radioactive Waste Tank Farms Construction Permit No. 17,424-IW* (hereinafter referred to as Construction Permit #17,424-IW), and the SRS Federal Facility Agreement (FFA) which will control the subsequent remediation of the FTF and HTF. [DHEC_01-25-1993, WSRC-OS-94-42]

The CGCP establishes the protocol by which the U. S. Department of Energy (DOE) intends to close waste tank systems and ancillary structures at SRS and receive approval from the South Carolina Department of Health and Environmental Control (SCDHEC) following public comment. Specifically, CGCP Section 11, *Closure Module Preparation and Approval*, outlines the requirements for Closure Module (CM) content, development, and approval. This CM supports the RFS of F-Area Diversion Boxes 5 and 6 (FDB-5, FDB-6) in the FTF under Construction Permit #17,424-IW. [DHEC_01-25-1993]

The SRS is a Federal facility owned by DOE. Since beginning operations in the early 1950s, uranium and plutonium recovery processes have generated liquid radioactive waste, which is currently stored in underground waste tanks and contacted ancillary structures in the F and H Areas at the site. The DOE intends to remove from service all of the ancillary structures and waste tanks with priority being given to the old-style waste tanks that do not meet the standards established in Appendix B of the SRS FFA. [WSRC-OS-94-42] The FFA has been entered into pursuant to Section 120 of the Comprehensive Environmental Response, Compensation, and Liability Act (CERCLA), Sections 3008(h) and 6001 of the Resource Conservation and Recovery Act (RCRA), as amended by the Hazardous and Solid Waste Amendments of 1984 (hereinafter jointly referred to as RCRA) and the Atomic Energy Act of 1954 (AEA), as amended, 42 U.S.C. § 2011.¹ [WSRC-OS-94-42] Once SCDHEC, the U. S. Environmental Protection Agency (EPA), and DOE mutually agree that waste removal from FDB-5 and FDB-6 may cease, any residual contaminants will be stabilized through operational closure, and then these ancillary structures will be removed from service under Construction Permit #17,424-IW. [DHEC_01-25-1993] Subsequently, the stabilized structures will be monitored and maintained in accordance with the requirements of an Interim Record of Decision (IROD) and the SRS RCRA Hazardous Waste Permit, Module VIII, as solid waste management units.

The DOE intends to remove FDB-5 and FDB-6 from service in accordance with SCDHEC Regulation 61-82, *Proper Closeout of Wastewater Treatment Facilities*, and SCDHEC Regulation 61-67, *Standards for Wastewater Facility Construction*. In addition, the FDB-5 and FDB-6 RFS by this process is intended to be consistent with the applicable requirements of RCRA and CERCLA described in the FFA, which will govern the subsequent remediation of the FTF operable unit (OU). These regulations were reviewed at the time of development of this CM and have been verified not to have changed since the CGCP was issued. [SCDHEC R.61-82, SCDHEC R.61-67, WSRC-OS-94-42, SRR-CWDA-2017-00015]

¹ DOE's submittal of this plan does not waive any DOE claim of jurisdiction over matters reserved to it under the Atomic Energy Act of 1954.

A performance assessment (PA) has been developed for FTF to assess the long-term fate and transport of residual contaminants in the environment resulting from the RFS of the FTF waste tanks and ancillary structures. [SRS-REG-2007-00002] Considering the layout of the FTF and the presumed footprint of a potential closure cap (if deemed necessary and appropriate when a final remedy is selected for the FTF OU), it is expected that monitoring wells will be located approximately 100 meters from the FTF boundary (i.e., line of demarcation enclosing the FTF waste tanks). In accordance with DOE M 435.1-1, the FTF PA used 100 meters as a point of assessment to predict long-term performance. [DOE M 435.1-1]

This CM describes the method by which DOE developed the assigned inventories for residual materials possibly remaining in FDB-5 and FDB-6, and the plans to isolate these ancillary structures from the FTF facilities that remain operable. This CM was developed using the assigned inventories for FDB-5 and for FDB-6. The assigned inventories are based on identified waste composition and properties from data in the SRS Waste Characterization System (WCS) (the WCS tracks waste data including projected radionuclide and non-radiological inventories based on sample analyses, process histories, compositional studies, and theoretical relationships.) The total radiological and chemical inventories assigned to FDB-5 and FDB-6 were calculated based on these concentrations multiplied by the total affected surface area of the respective ancillary structure. [SRR-CWDA-2020-00029] A Special Analysis (SA) was then performed using the FDB-5 and FDB-6 assigned inventories. DOE has confirmed that regulatory performance objectives will be met and that the stabilized FDB-5 and FDB-6 configurations would be protective of human health and the environment.

Based on the information provided in this CM and supporting documents, it may be concluded that (1) there is reasonable assurance that, at the time of final FFA corrective/remedial actions, groundwater concentrations derived from residual contamination in the waste tanks and ancillary structures will meet the regulatory performance objectives and (2) further waste removal is not technically practicable from an engineering perspective.

Through completion of this CM, DOE will have determined that all CGCP requirements have been met to proceed with removing FDB-5 and FDB-6 from service and that DOE is ready to complete the process by stabilizing these ancillary structures with grout. Through approval of this CM, SCDHEC is agreeing that waste removal activities for FDB-5 and FDB-6 can cease and authorizes stabilization of these ancillary structures and the residual contaminants under Construction Permit #17,424 IW. [DHEC_01-25-1993] Following operational closure, DOE will submit separate Final Configuration Reports (FCRs) for FDB-5 and FDB-6 to SCDHEC (as described in the CGCP) with certification that the RFS activities have been performed in accordance with the CGCP and this CM.

1.0 INTRODUCTION

Since the early 1950s, the primary SRS mission had been to produce nuclear materials primarily for national defense and deep space missions. A legacy of the SRS mission was the liquid waste generated from chemical separations processes in both F and H Areas. Since the beginning of SRS operations, an integrated Liquid Waste System consisting of several facilities designed for the overall processing of liquid waste has evolved. Two of the major system facilities are the FTF and HTF located in F Area and H Area, respectively, which are near the center of the site (Figure 1.0-1). In F Area, plutonium, uranium, and other radionuclides were extracted from target assemblies using chemical separation processes with the resultant waste being sent to the underground tanks in the FTF. The tank farms, which store and process the chemical separations waste, include waste tanks and ancillary structures such as evaporators, transfer line systems, pump tanks and pump pits, and diversion boxes.

In this document the term “ancillary structure” will refer to structures, systems, and equipment within the FTF, other than the underground waste storage tanks, that may contain a residual chemical and radioactive material inventory and must be accounted for as part of the FTF closure.

Figure 1.0-1: SRS Operational Area Location Map

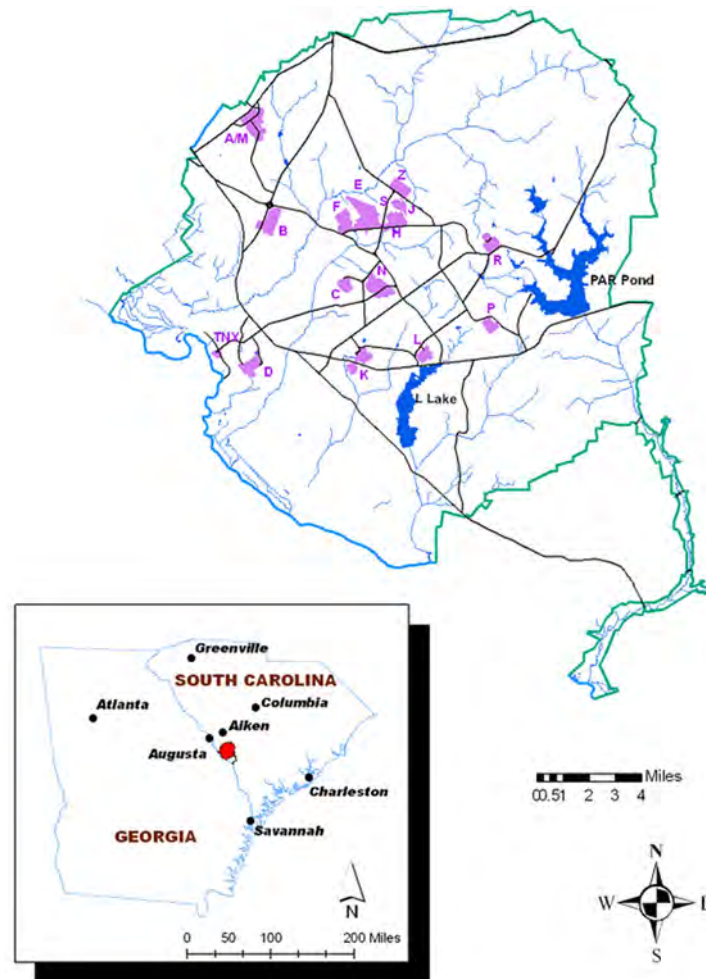

In support of environmental remediation activities at SRS; DOE, EPA, and SCDHEC signed the SRS FFA pursuant to Section 120 of CERCLA, and Sections 3008(h) and 6001 of RCRA. The agreement became effective in August 1993. As part of this comprehensive agreement, DOE committed to submit and comply with a schedule to remove from service those liquid radioactive waste tank systems that do not meet the standards set forth in Appendix B of the FFA. Appendix B of the FFA also describes the specific radioactive waste tank systems that are subject to the agreement. [WSRC-OS-94-42]

The CGCP establishes the general protocols for the RFS of the FTF and HTF waste tanks and ancillary structures in accordance with SCDHEC R.61-82 and SCDHEC R.61-67. This CM provides specific information on the FDB-5 and FDB-6 RFS in the FTF and demonstrates activities have been performed in accordance with requirements set forth in CGCP Section 11.0, *Closure Module Preparation and Approval*. [SRR-CWDA-2017-00015]

This CM supports the FDB-5 and FDB-6 RFS in the FTF under Construction Permit #17,424-IW. [DHEC_01-25-1993]

This CM contains the following elements:

Introduction (Section 1.0) – Defines this CM purpose and scope.

Facility Description (Section 2.0) – Describes FDB-5 and FDB-6 and provides a history of each ancillary structure.

Waste Removal (Section 3.0) – Describes the process used to document the absence of waste in FDB-5 and confirm the amount of waste remaining in FDB-6.

Residual Material Characterization (Section 4.0) – Details the development of the FDB-5 and FDB-6 assigned inventories.

Performance Evaluation (Section 5.0) – Presents the FDB-5 and FDB-6 SA results for the predicted groundwater concentrations using the assigned inventories and the FTF baseline fate and transport modeling.

Waste Removal Analysis (Section 6.0) – Discusses that it is not technically practicable from an engineering perspective to conduct additional waste removal activities in either FDB-5 or FDB-6. This analysis considers technology capabilities, and relative benefit.

System Isolation and Stabilization (Section 7.0) – Describes the plans to isolate and grout FDB-5 and FDB-6, and the fill material type and characteristics.

Maintenance and Monitoring (Section 8.0) – Describes the FTF maintenance and monitoring plans that will be used for the interim period from the FDB-5 and FDB-6 RFS until the FTF OU final closure.

Conclusion (Section 9.0) – Provides the conclusion that DOE has demonstrated that the proposed RFS configurations are protective of human health and the environment and that the closure actions will continue to be supportive of meeting the applicable performance standards for the FTF OU closure.

Waste Tank Systems Tracking (Appendix A) – This section tracks the FTF waste tanks and ancillary structures listed in the CGCP to ensure that all required FTF waste system components will be addressed in a CM. This table will be updated in each subsequent CM with the RFS date and the CM document number that addresses each FTF waste tank and ancillary structure.

2.0 FACILITY DESCRIPTION

The FTF is a 22-acre site containing 22 underground liquid waste storage tanks and associated ancillary structures, including two evaporator systems, a concentrate transfer system (CTS), six diversion boxes (DBs), one catch tank, three pump pits (PPs), and waste transfer pipelines. Figure 2.0-1 shows the general layout of FTF and the locations of FDB-5 and FDB-6. The FTF was constructed to receive waste generated by various SRS production, processing, and laboratory facilities. Detailed descriptions of the FTF facilities are provided in the FTF PA. [SRS-REG-2007-00002]

The FTF site was originally chosen because of its favorable terrain, proximity to the F-Canyon Separations Facility (the major waste generation source), and isolation distance (at least 5.5 miles) from the SRS boundaries. Figure 2.0-2 shows the setting of F Area and FTF within the SRS General Separations Area (GSA).

Figure 2.0-1: Layout of the F-Area Tank Farm and Locations of FDB-5 and FDB-6

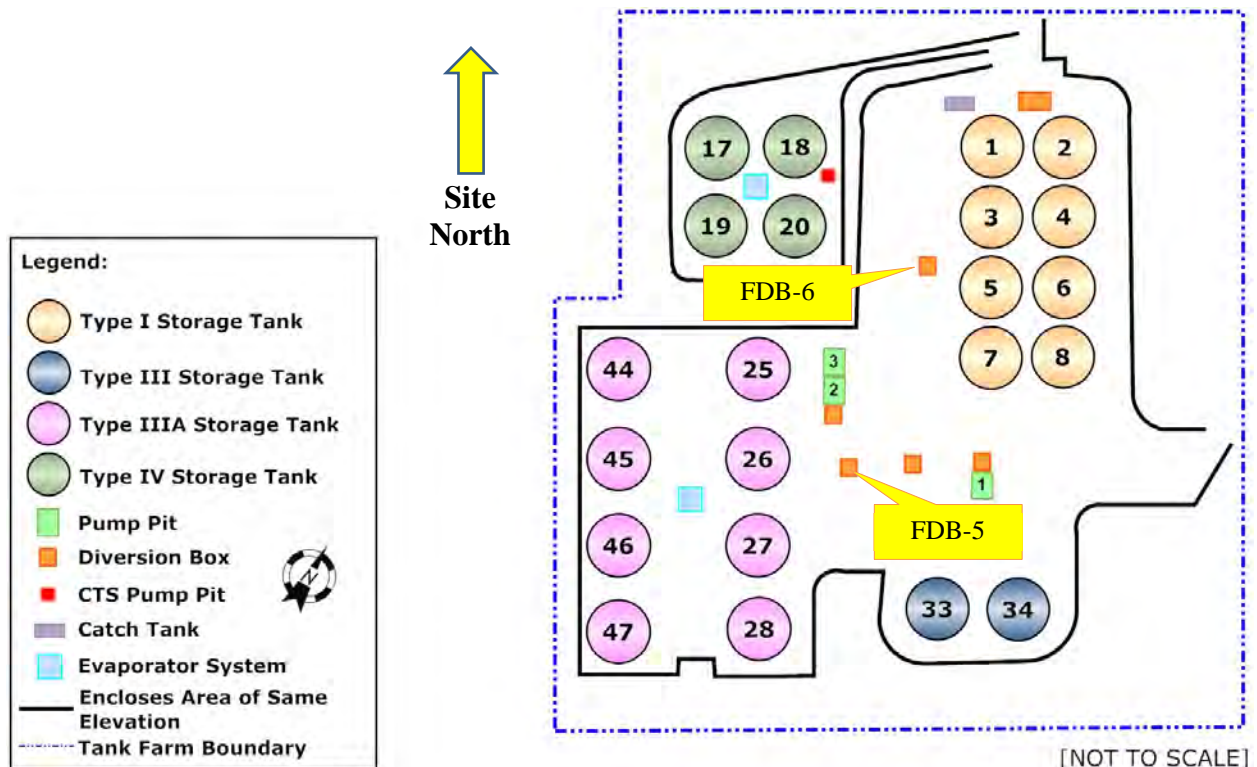
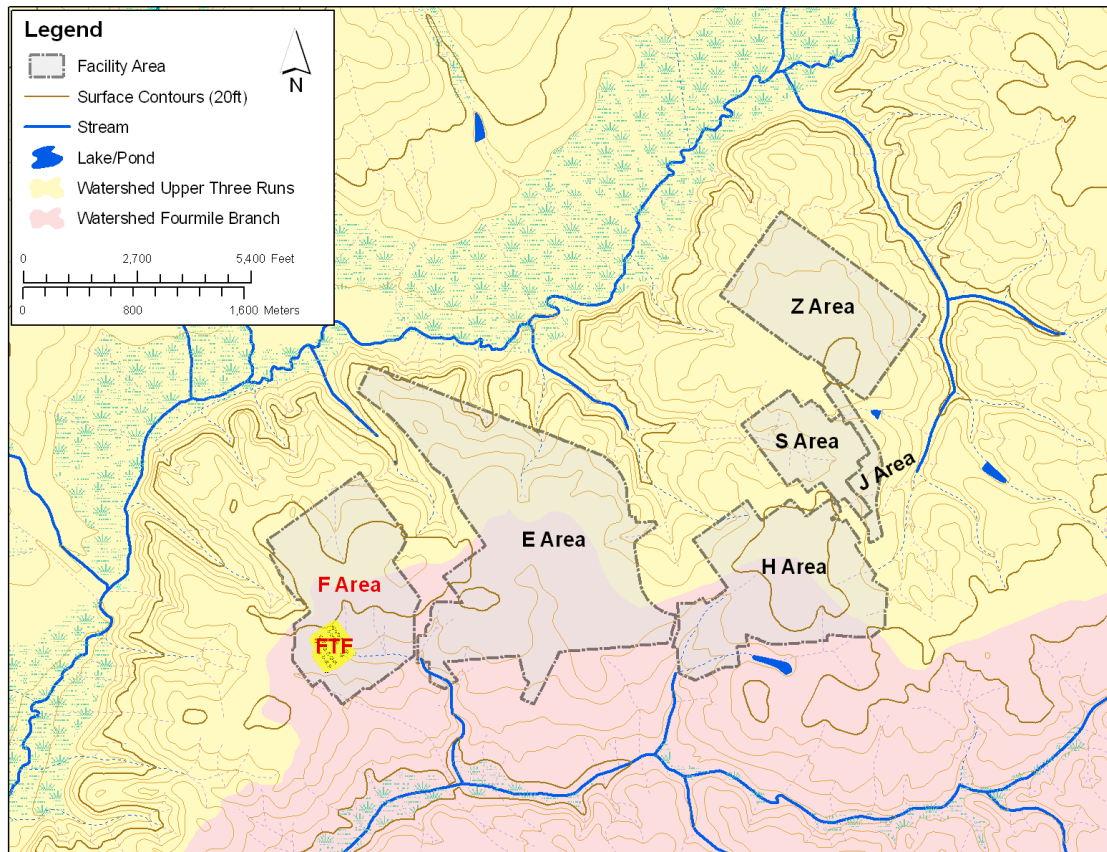

Figure 2.0-2: Layout of the GSA Showing F Area and the FTF



Diversion boxes are junction chambers used to interconnect dedicated waste transfer lines. Most dedicated transfer lines are routed to a wall-mounted nozzle inside a DB. The transfer lines can be interconnected by installing “jumpers” between nozzles to complete the desired transfer path. Transfer paths can be redirected by switching jumpers inside a DB rather than installing new transfer lines. Jumpers are stainless-steel pipe segments specifically fabricated to an exact length and balance. They have special end connections (Hanford connectors) designed to seal against the DB wall nozzles to complete a transfer path.

A Hanford connector is a specially designed clamp with a gasketed seal affixed to each end of a jumper. When tightened, the jaws of the clamp close and seat the jumper end-gasket securely onto a wall nozzle. The seal prevents leakage during a waste transfer. The clamp portion is tightened remotely using an impact wrench suspended from a crane. The wall nozzles in FDB-6 also have a separate inlet line so that flush water can be added directly into the transfer line following a transfer. Any leakage from a jumper connection would be contained inside the DB and would gravity drain into a floor sump and leak detection box (LDB) system. The sump can be drained independently to a PP for transfer to a waste tank.

Pump pits are intermediate pumping stations in the FTF and HTF waste transfer systems and are located at the low point of a transfer line. Pump pits contain a pump tank and hydraulic pumps and/or jet pumps to transfer wastes and associated transfer line water flushes.

FDB-5 and FDB-6 were part of the FTF waste transfer system. FDB-5 was built in the mid-to-late 1970s to make waste transfers from the 242-3F CTS to Tanks 25F through 28F, 33F, and 34F. FDB-6 was built in the late 1970s for feed material transfers to the 242-1F Evaporator from Tanks 26F and 7F.

2.1 FDB-5 Design and Construction

Figures 2.1-1 and 2.1-2 show a plan view, cross-sections, and various design features of FDB-5. The DB is a rectangular concrete structure 13-feet long, 11.25-feet wide, and 17.17-feet high (inside dimensions) with the long axis oriented north-south.² It has walls 2.5-feet thick and a base slab approximately 4.7-feet thick. The vault floor is approximately 16 feet below grade. The vault extends approximately 4 feet above grade and has three, 3-foot thick interlocking concrete cell covers oriented east-west. [W702452] The interior vault walls and floor are lined with welded stainless-steel sheets. The wall sheets are approximately 0.125-inches thick. The exterior vault walls were coated with a damp-proofing compound during construction. A west-to-east sloping, sheet metal rain cover has been placed over the vault top. A north-to-south series of supporting I-beams on the underside of the cover create a gap between the top of the cell covers and underside of the rain cover. The gap decreases in height from approximately 10 inches on the west side to approximately 5.5-inches on the east side. The rain cover has one sealable case in the northeast corner covering a single 5-inch inside diameter (I.D.) Schedule 40 pipe riser that penetrates the concrete cell cover above the sump in the vault floor.

The vault has a stainless-steel lined sump in the northeast corner of the floor that is 3-feet long, 2-feet wide, and 1.6-feet deep (Figure 2.1-1). The stainless-steel sheets lining the vault floor and sump are 0.375-inches thick. The vault floor slopes towards a gutter along the east wall that drains to the sump. [W703321] A low, stainless-steel screen is present on the south and west sides of the sump and in the gutter notch (Figure 2.1-2).

The sump can be gravity drained to F-Area Pump Pit (FPP)-2. Sump drainage is controlled by a plug on the end of a fixed rod actuated through the 5-inch riser in the cell cover. A sump overflow line exits the north vault wall at an elevation just below the top of the sump screen. Waste drain lines from clean-outs enter FDB-5 through the transfer line jackets at Nozzles 3 and 4 and Nozzles 9 and 10. There is also a capped drain line entering FDB-5 through the transfer line jacket at Nozzles 7 and 8. The drain lines exit the vault through an opening sealed in the north vault wall approximately 3 feet above the sump bottom and join the sump drain line to FPP-2 (Figure 2.1-2).

A system of underliner leak detection slots was formed into the concrete floor surface underneath the stainless-steel vault floor liner. The underliner leak detection system is piped to an LDB outside the northeast corner of the vault (Figure 2.1-1).

There is a flush water valve box at grade on the northeast vault corner. It was used to activate a spray water nozzle system to rinse the DB interior if needed. The valve box is 3-feet long, 1.5-feet wide, and 2.7-feet deep and has a 1-foot thick concrete cover, but no rain cover. The flush water piping enters the vault through an 8-inch wide by 10-inch high open slot on the north wall approximately 14 feet above the vault floor. [W702452]

² All compass directions given are based on site north which is approximately 36° 22' west of true north.

A set of metal stairs on the southeast corner of FDB-5 provides access to the top of the vault. FDB-5 has a High Efficiency Particulate Air (HEPA) ventilation system at grade on the east side of the vault (Figure 2.1-1).

There are 10 wall nozzles in FDB-5. The north, south, and east vault walls each have two wall-mounted nozzles for waste transfer line (jumper) connections using Hanford connectors. The west wall has four nozzles (Figure 2.1-2). Spare wall Nozzles 5, 6, 7, and 8, that were installed for future transfer line connections, are blanked off using dummy Hanford connectors. Several metal “pedestals” on the vault floor support the installed jumpers. There are two abandoned jumpers on the vault floor.

Figure 2.1-3 is a photograph of the northeast corner of FDB-5 showing the flush water valve box and sealable case covering the vault access riser above the sump.

Figure 2.1-1: Plan View of FDB-5 and Cell Covers

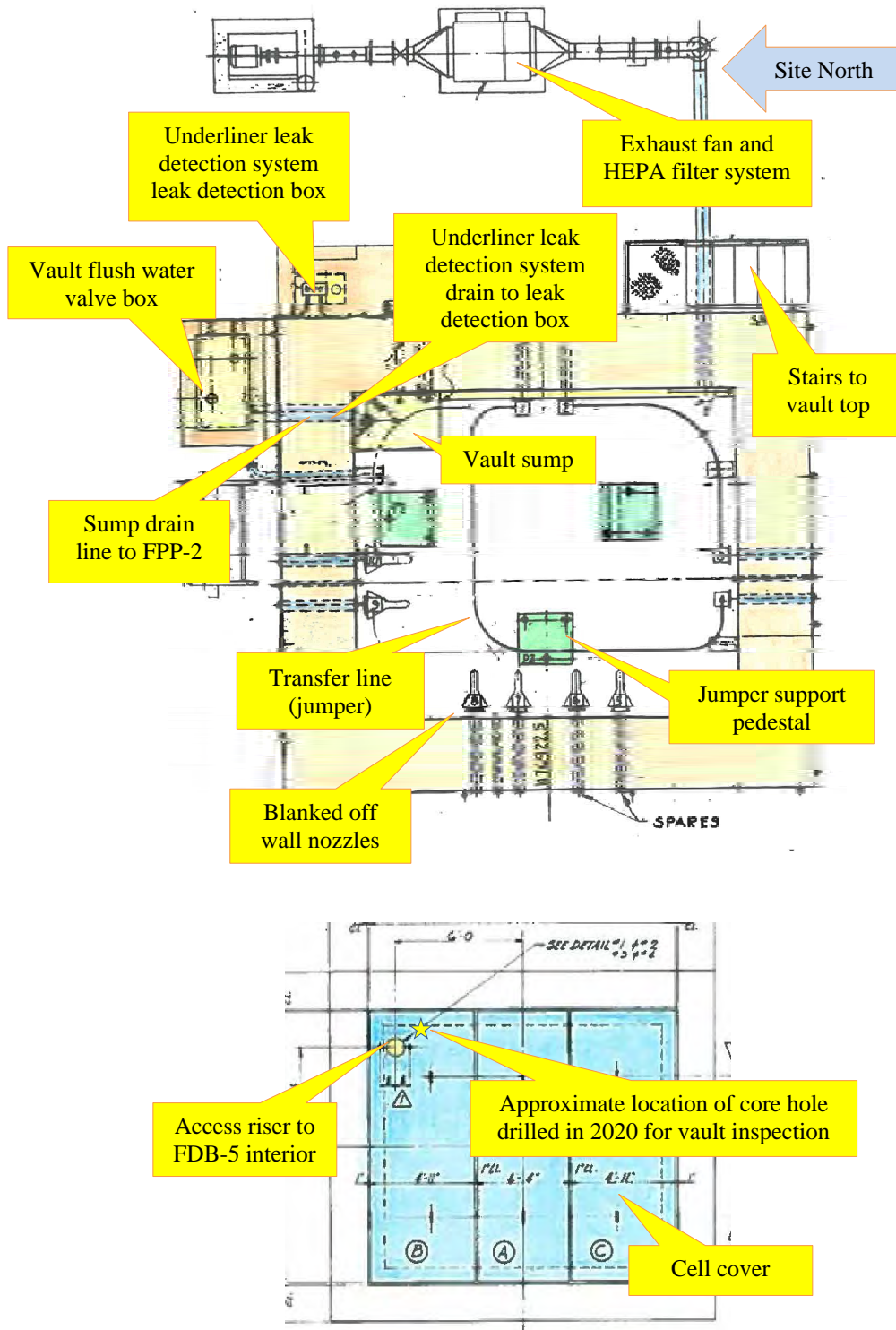

[W703320]

Figure 2.1-2: Cross-Sections of FDB-5 Showing the Sump, Leak Detection Box, and Vault Flush Water Valve Box and Piping Inlet

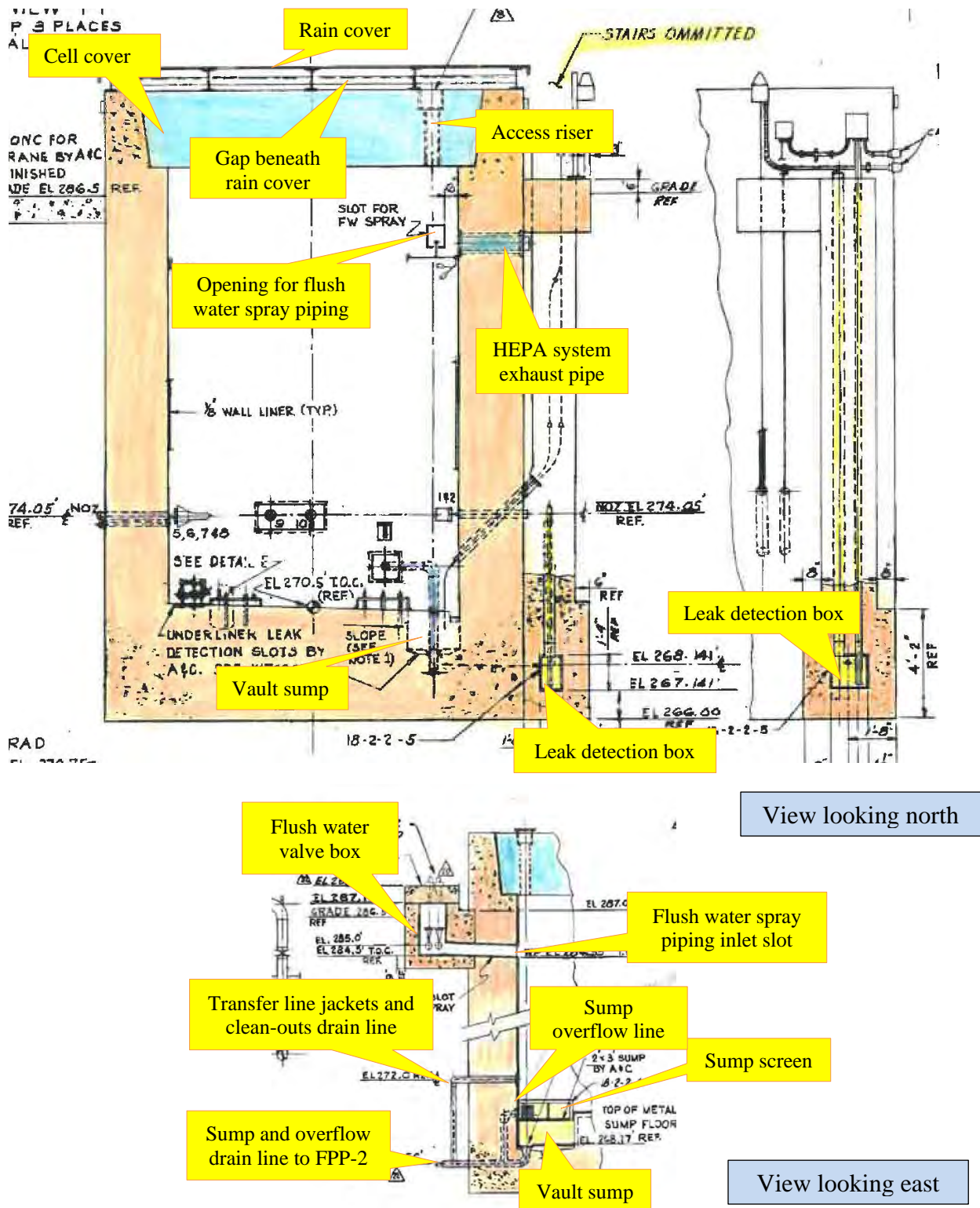

[W702452]

Figure 2.1-3: View of the FDB-5 Northeast Corner, Flush Water Valve Box, and Vault Access Riser Area. View to Southwest, May 2018.

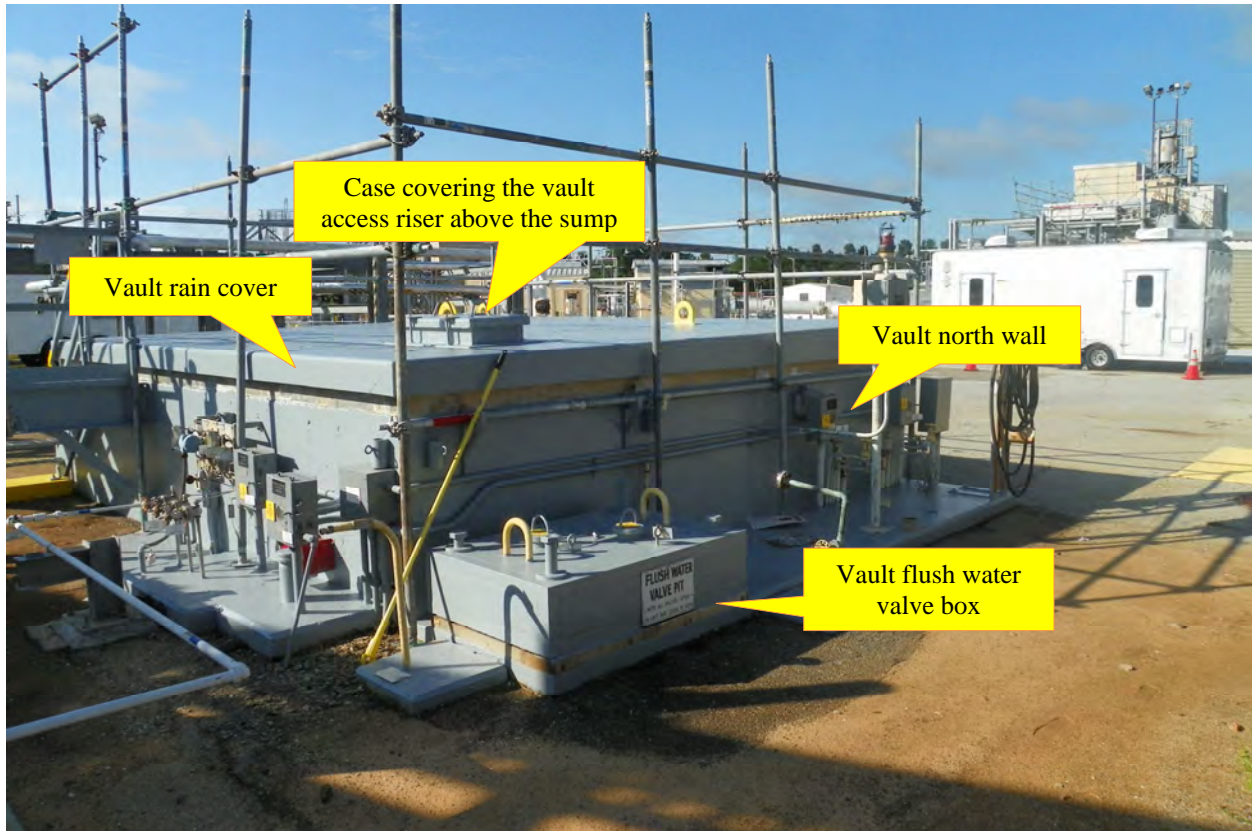

2.2 FDB-5 Vault Piping

There are several piping penetrations through the FDB-5 vault walls for the waste system transfer lines while others are for drainage, leak monitoring, instrument air supply, and vault ventilation.

Figure 2.2-1 is a schematic of the internal FDB-5 waste transfer piping. The 10 waste transfer lines are all 2-inch I.D., Schedule 40 stainless-steel. All waste transfer lines are inside secondary containment jackets that drain to leak detection boxes. Because multiple lines may be inside one jacket, the jackets range from 6 to 10 inches in diameter. The vault flush water lines are 0.75-inches I.D. The current line status is summarized in Table 2.2-1. Details on the additional lines inside the vault are summarized in Table 2.2-2.

Figure 2.2-1: FDB-5 Waste Transfer Piping System Diagram

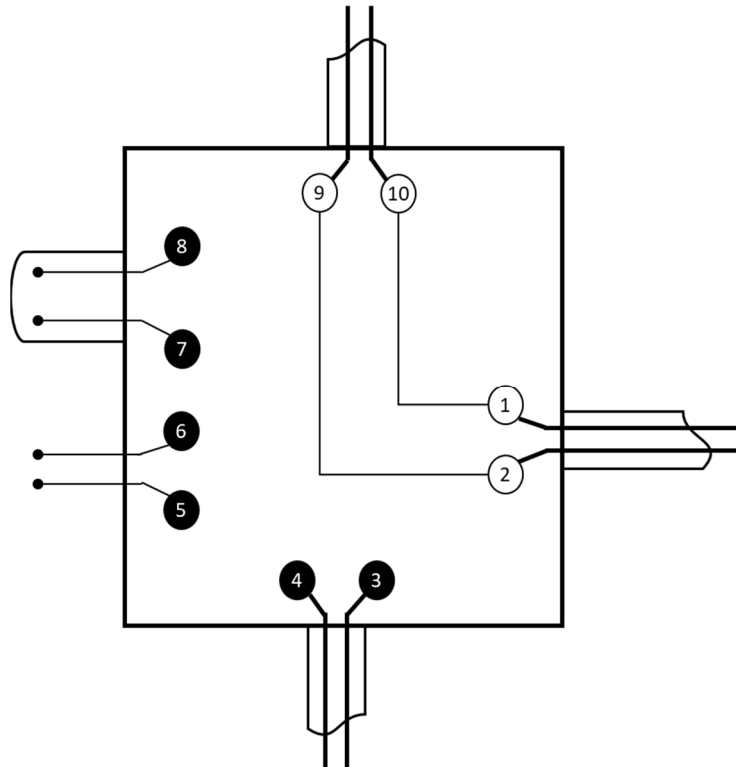

[M-M6-F-3123]

Table 2.2-1: Current Status of FDB-5 Waste Transfer Piping System

Nozzle Number	Purpose	Nozzle status in FDB-5	Transfer Line Termination Status
1	From 242-3F CTS Pump Tank	Jumpered to Nozzle 10	Dummy Hanford connector in 242-3F CTS Pump Pit
2	To 242-3F CTS Pump Tank	Jumpered to Nozzle 9	Dummy Hanford connector in 242-3F CTS Pump Pit
3	From Tank 33F	Dummy Hanford Connector	Tank 33F Riser C2
4	To Tank 34F	Dummy Hanford Connector	Tank 34F Riser C2
5	Spare	Dummy Hanford Connector	Capped at FDB-5
6	Spare	Dummy Hanford Connector	Capped at FDB-5
7	Spare	Dummy Hanford Connector	Capped at FDB-5
8	Spare	Dummy Hanford Connector	Capped at FDB-5
9	From Tank 28F	Jumpered to Nozzle 2	Tank 28F Riser C2
10	To Tank 25F	Jumpered to Nozzle 1	Tank 25F Riser C2

[after M-M6-F-3123]

Table 2.2-2: Additional FDB-5 Vault Piping System Lines

Pipe Size (I.D. Inches)	Purpose
6	Ventilation Duct for the HEPA system
1	To LDB-1
1	To LDB-2
1	To LDB-3
1.5	Transfer line jackets and clean-out drains to sump drain line
3	Sump drain system to FPP-2
1	Sump overflow line
1	Instrument air (3 lines)
0.75	Flush water supply line to vault spray nozzles

[after M-M6-F-3123]

2.3 FDB-5 Operational History

FDB-5 was constructed in the mid-to-late 1970's and used between March 1980 and September 1985. FDB-5 was used to transfer waste between the 242-3F CTS, Tanks 25F through 28F, and Tanks 33F and 34F. The transfers through FDB-5 were only concentrated evaporator discharge (supernate). No "fresh canyon waste" or "sludge slurry" were sent through FDB-5.

FDB-5 is currently inactive.

2.3.1 FDB-5 Decontamination History

FDB-5 had a history of jumper plugging caused by the concentrated, high-salt CTS waste crystallizing inside the transfer lines during cold weather. When a line became plugged, the jumper was disconnected and lifted near the top of the vault. A "skill-of-the-craft catheterization procedure" was used to dissolve the internal salt and flush the line. The procedure involved inserting a polyethylene tube fed with water into the disconnected jumper to dissolve and flush out the very soluble salt waste. After the salt dissolution was complete, the FDB-5 interior walls and floor were washed using the jumper flushing apparatus. The waste and wash water would collect in the sump and then be gravity-drained to FPP-2. [SRR-CWDA-2018-00059]

Aside from the jumper cleanings, FDB-5 has no known waste leakage or spillage events. [SRR-CWDA-2018-00059]

2.4 FDB-5 Inspections

Two video camera inspections were performed on FDB-5. The first was in November 2018 and the second in February 2020. The February 2020 inspection required coring a 6-inch diameter hole through a cell cover so a wider vault area could be inspected using a larger camera. The location of the cored hole is shown in Figure 2.1-1.

November 1, 2018

In November 2018, the FDB-5 vault interior was inspected using a small “lipstick” camera. The larger, full-size inspection camera normally used could not be inserted into the vault because the area below the access riser was partially blocked by the sump drain plug actuating rod. [V-18-0791] During the inspection, no solids were seen on the vault floor or in the sump within the limited viewing area (Figure 2.4-1). White staining on the vault walls appeared to be associated with rainwater intrusion around the edges of the cell covers prior to the rain cover installation.

Figure 2.4-1: View Looking Down at the FDB-5 Sump (November 2018)

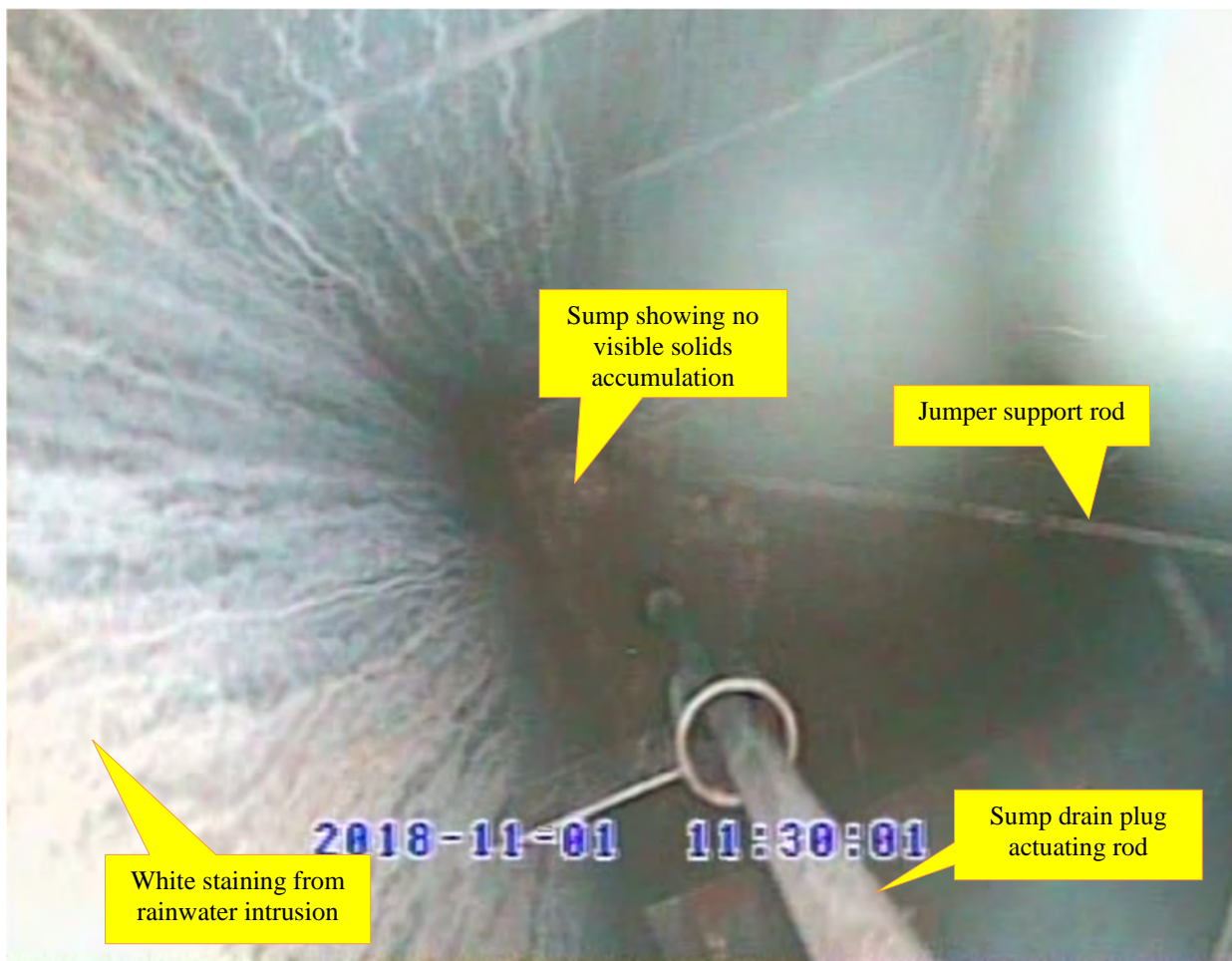

February 5, 2020 Inspection

In February 2020, a 6-inch diameter hole was cored through the cell cover approximately 32 inches southeast of the access riser (Figure 2.1-1) and the vault interior was inspected. This second inspection confirmed the jumper and wall nozzle status and that there was no obvious solid waste on the cell walls and floor (Figures 2.4-2 through 2.4-4). [V-20-0140] During the inspection and smear sampling of the floor, the sump screen became dislodged and came to rest across the sump (Figure 2.4-4).

Radiation monitoring using portable, direct reading, ion chamber survey instruments during the coring and inspection, measured a 1 mrem/hr extremity dose and no skin, or whole-body dose over the open core hole. [TKFM-M-20200205-28]

Figure 2.4-2: Views of the FDB-5 Vault Interior



Figure 2.4-3: Close-up View of FDB-5 Northwest floor Area (February 5, 2020)

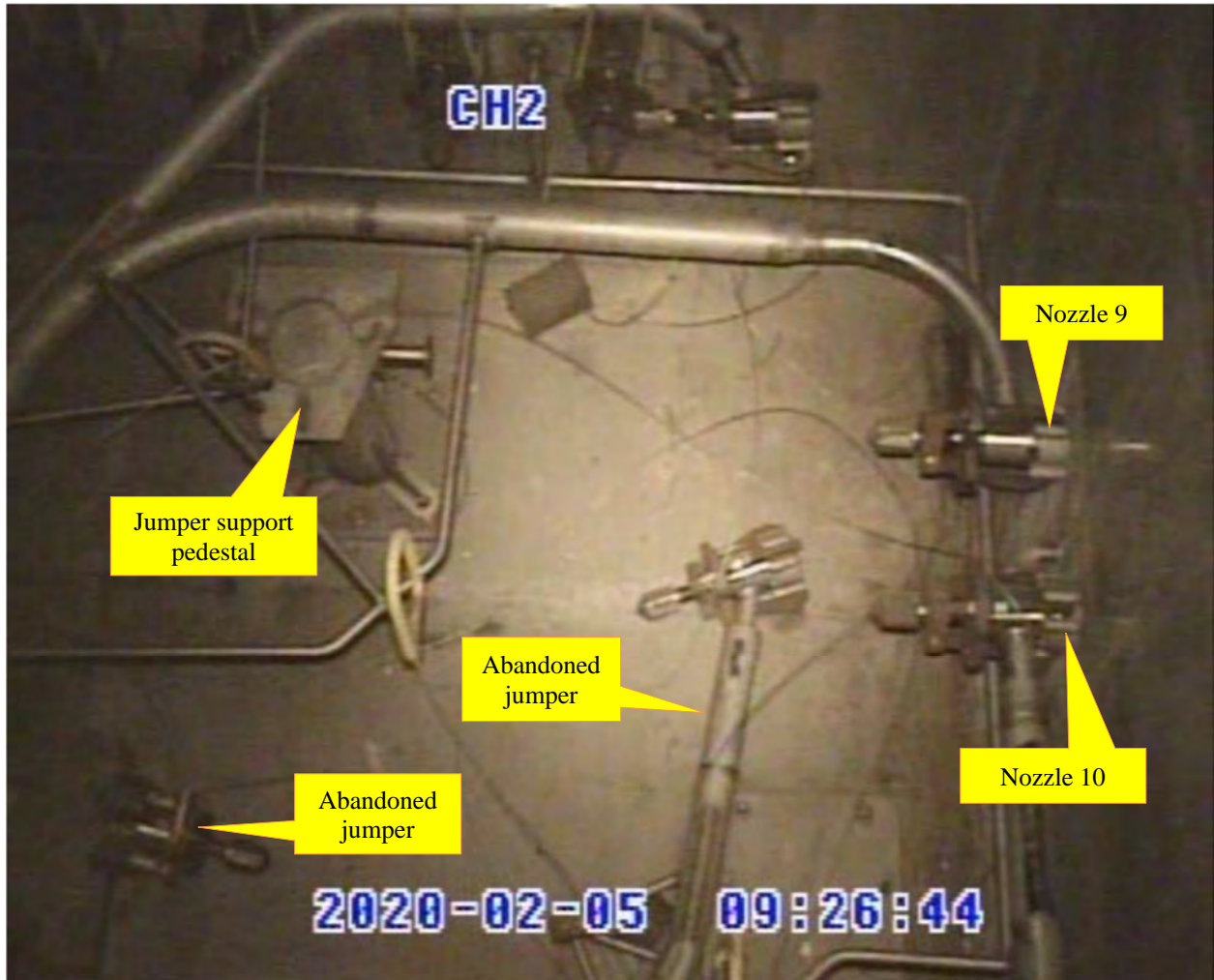
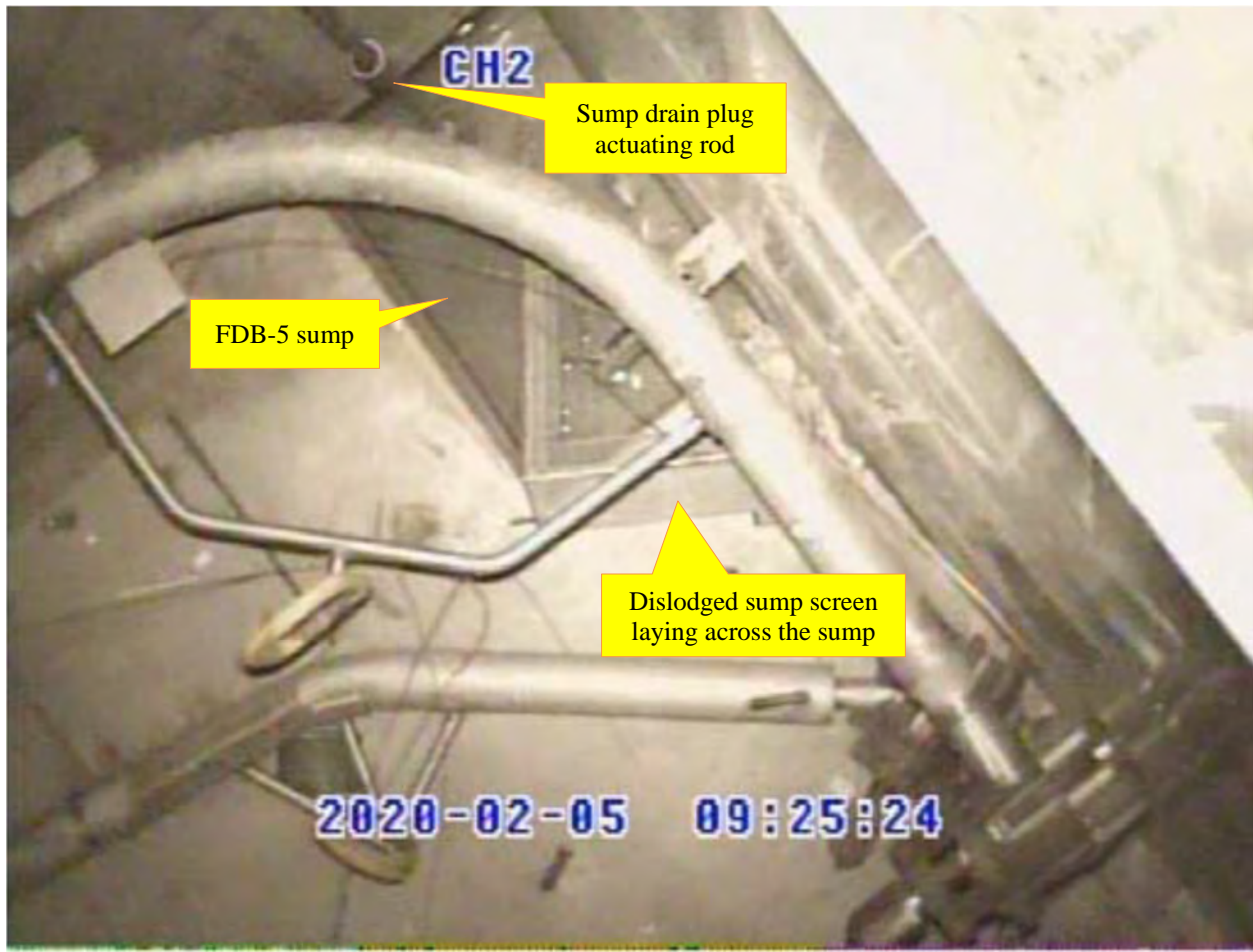

Figure 2.4-4: Close-up View of FDB-5 Sump Area (February 5, 2020)



2.5 FDB-6 Design and Construction

Figures 2.5-1 through 2.5-3 show a plan view, cross-sections, and various design features of FDB-6. The DB is a rectangular concrete structure 15-feet long, 11-feet wide, and 18-feet high (inside dimensions) with the long axis oriented east-west. It has walls 2.5-feet thick and a base slab approximately 4.7-feet thick. The vault floor is approximately 16.6 feet below grade. The vault extends approximately 4 feet above grade and has five, 3-foot thick interlocking concrete cell covers oriented north-south (Figure 2.5-3). The interior vault walls and floor are lined with welded stainless-steel sheets. The wall sheets are approximately 0.125-inches thick. The exterior vault walls were coated with a damp-proofing compound during construction. [W702275] A north-to-south sloping sheet metal rain cover has been placed over the vault top. An east-west series of supporting I-beams on the underside of the cover create a gap between the top of the cell covers and underside of the rain cover. The gap decreases in height from approximately 10 inches on the north side to 5.5 inches on the south side. The rain cover has four individual sealable cases covering the four, 5-inch I.D. Schedule 40 pipe risers penetrating the concrete cell covers (Figures 2.5-1 and 2.5-4).

The vault has a stainless-steel lined sump in the southwest corner of the floor that is 3-feet long, 2-feet wide, and 1.6-feet deep. The stainless-steel sheets lining the vault floor and sump are 0.375-inches thick. The vault floor slopes towards a gutter along the west wall that drains to the sump. [W702275] A low, stainless-steel screen is present on the north and east sides of the sump and in the gutter notch (Figure 2.5-1).

The sump can be gravity drained to FPP-3. Sump drainage is controlled by a plug on the end of a fixed rod actuated through the 5-inch riser in the southwest corner of the western cell cover. A sump overflow line exits the west vault wall at an elevation just below the top of the sump screen. A clean-out drain line enters the vault via the Nozzle 5 jacket and exits the vault through an opening sealed in the south vault wall approximately 3 feet above the sump bottom and joins the sump drain line going to FPP-3 (Figure 2.5-1).

A system of underliner leak detection slots was formed into the concrete floor surface underneath the stainless-steel vault floor liner. The underliner leak detection system drains to an LDB outside the southwest corner of the vault (Figure 2.5-1).

There is a flush water valve box at grade on the southwest vault corner. The wall nozzles in FDB-6 have a special inlet for water addition that allowed the transfer lines used to be flushed following a waste transfer. One valve could also activate a spray water nozzle system to rinse the diversion box interior if needed. The valve box is 9-feet long, 2.5-feet wide, and 2.9-feet high (inside dimensions) and has a 1-foot-thick concrete cover, but no rain cover. The flush water piping enters the vault through a 6-foot wide and 8-inch high open slot in the south vault wall approximately 12 feet above the vault floor (Figure 2.5-2). [W702358]

A set of metal stairs on the southeast corner of FDB-6 provides access to the top of the vault. FDB-6 has a HEPA ventilation system at grade on the east side of the vault (Figure 2.5-1).

There are eight wall nozzles in FDB-6. The west, south, and east vault walls each contain wall-mounted nozzles for waste transfer line (jumper) connections. The south wall has four nozzles while the west and east walls each have two nozzles (Figure 2.5-1). Spare wall Nozzles 7 and 8, that were installed for future transfer line connections, are blanked off using dummy Hanford connectors. Several metal “pedestals” on the vault floor support the installed jumpers. There are two abandoned jumpers on the vault floor.

Figure 2.5-4 is a photograph of FDB-6 showing the flush water valve box, sealable cases covering the vault access risers, HEPA system, and stairs to the vault top. Figure 2.5-5 is a close-up of the FDB-6 vault top.

Figure 2.5-1: Plan View of FDB-6 and Cross-Sections of the Vault Sump and Underliner Drain System

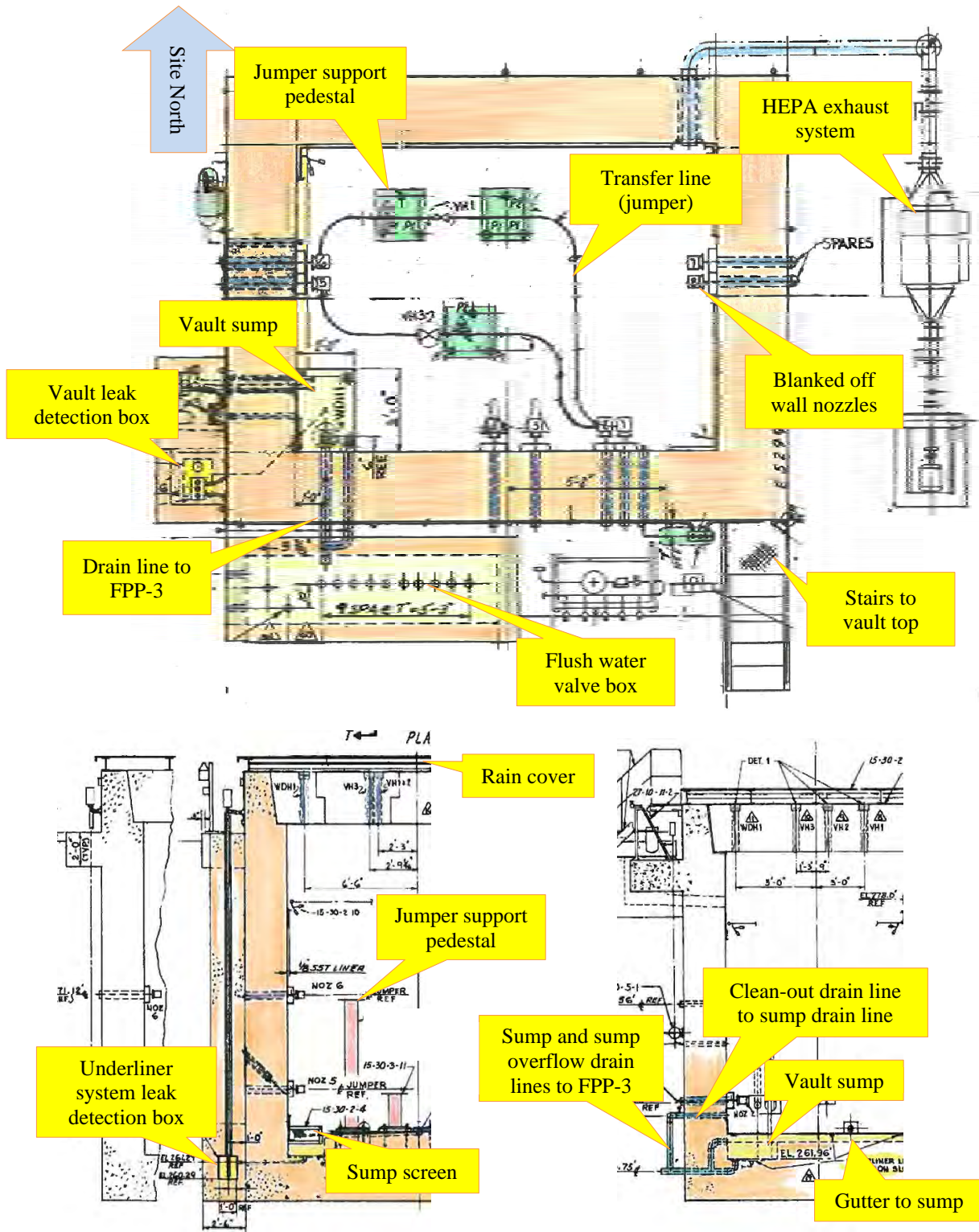

[W702275]

Figure 2.5-2: Cross-Section of FDB-6 Showing the Flush Water Valve Box Detail

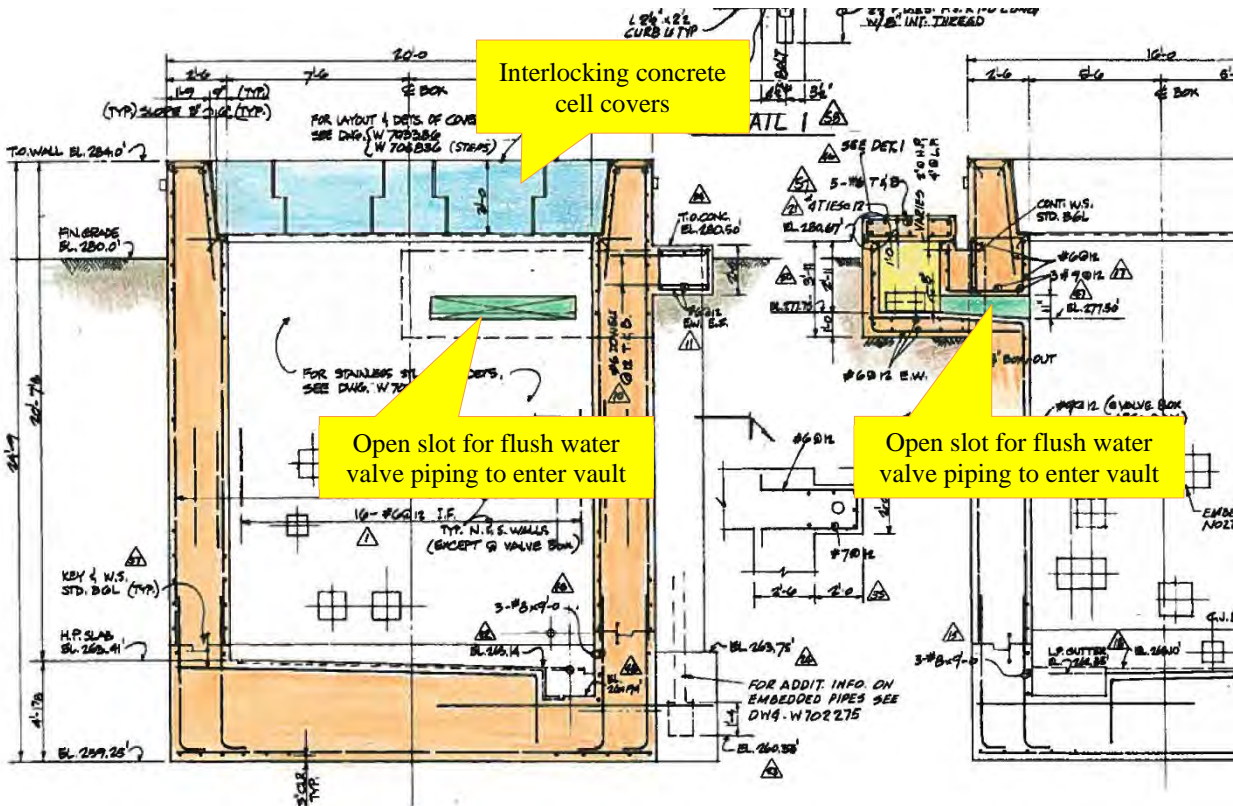

[W703384]

Figure 2.5-3: Plan View of the FDB-6 Cell Cover Slabs and Vault Access Risers

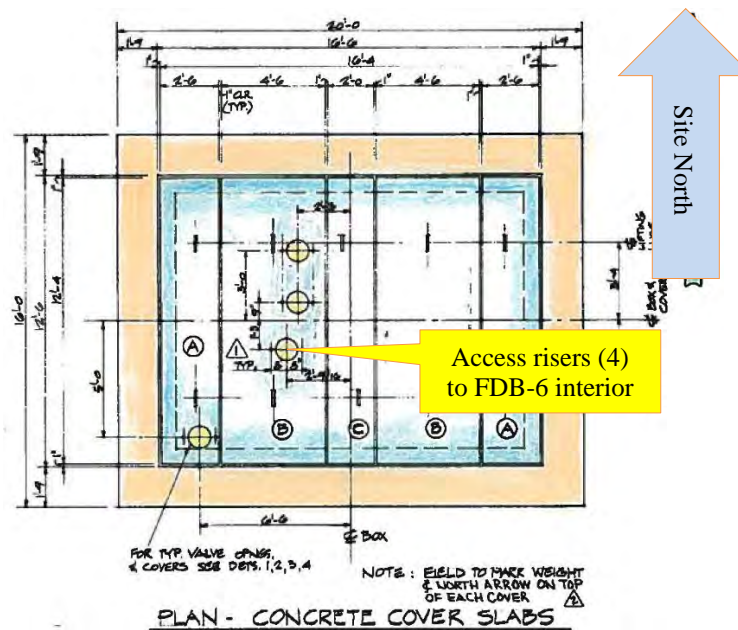

[W703386]

Figure 2.5-4: Aerial View of FDB-6 Showing Rain Cover, Cases Covering Vault Access Risers, Stairs to Vault Top, and HEPA System. View to West.

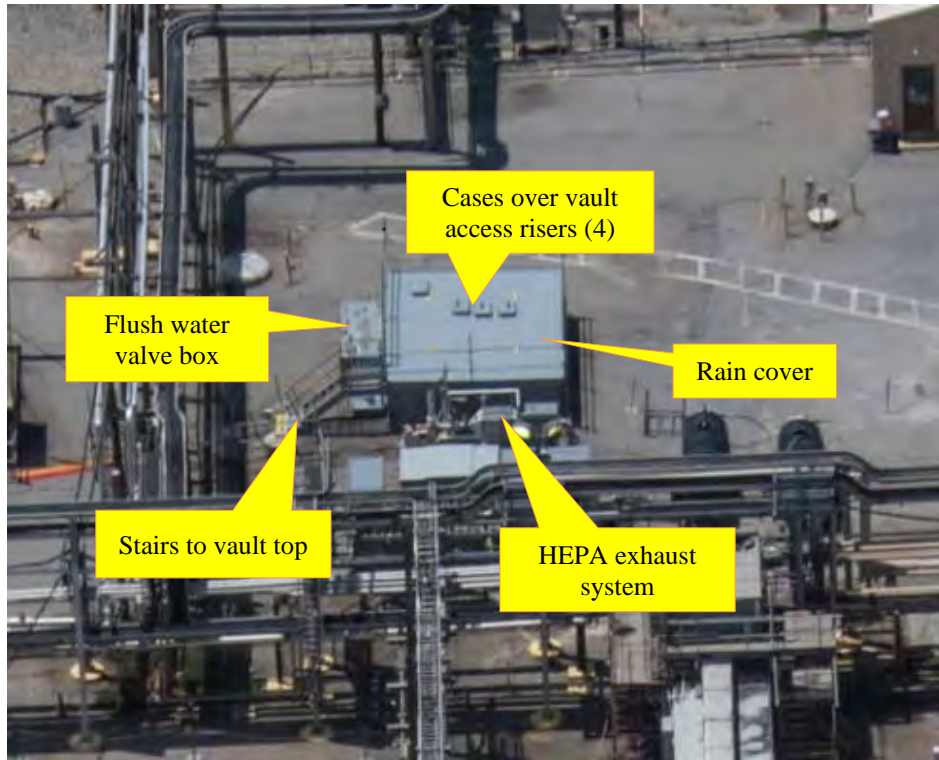
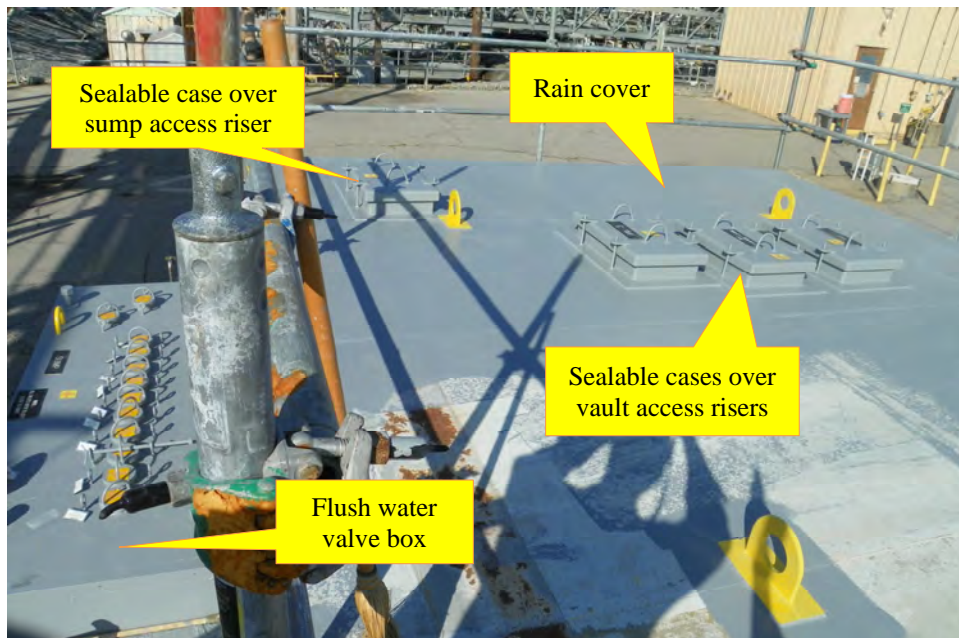

Figure 2.5-5: Close-up View of the FDB-6 Vault Top, Cases Covering Vault Access Risers and Flush Water Valve Box. View to West.



2.6 FDB-6 Vault Piping

There are numerous piping penetrations through the FDB-6 vault walls. Eight are for the waste system transfer lines while the others are for drainage, leak monitoring, instrument air supply, and vault ventilation.

Figure 2.6-1 is a schematic of the FDB-6 internal waste transfer piping. The eight waste transfer lines are all 3-inch I.D., Schedule 40 stainless-steel. All waste transfer lines are inside 4-inch secondary containment jackets that drain to leak detection boxes. The current line status is summarized in Table 2.6-1. Additional lines and their purpose are summarized in Table 2.6-2.

There are four access ports through the cell covers that have removable lead plugs (Figures 2.5-3 and 2.5-4).

Figure 2.6-1: FDB-6 Transfer Piping System Diagram

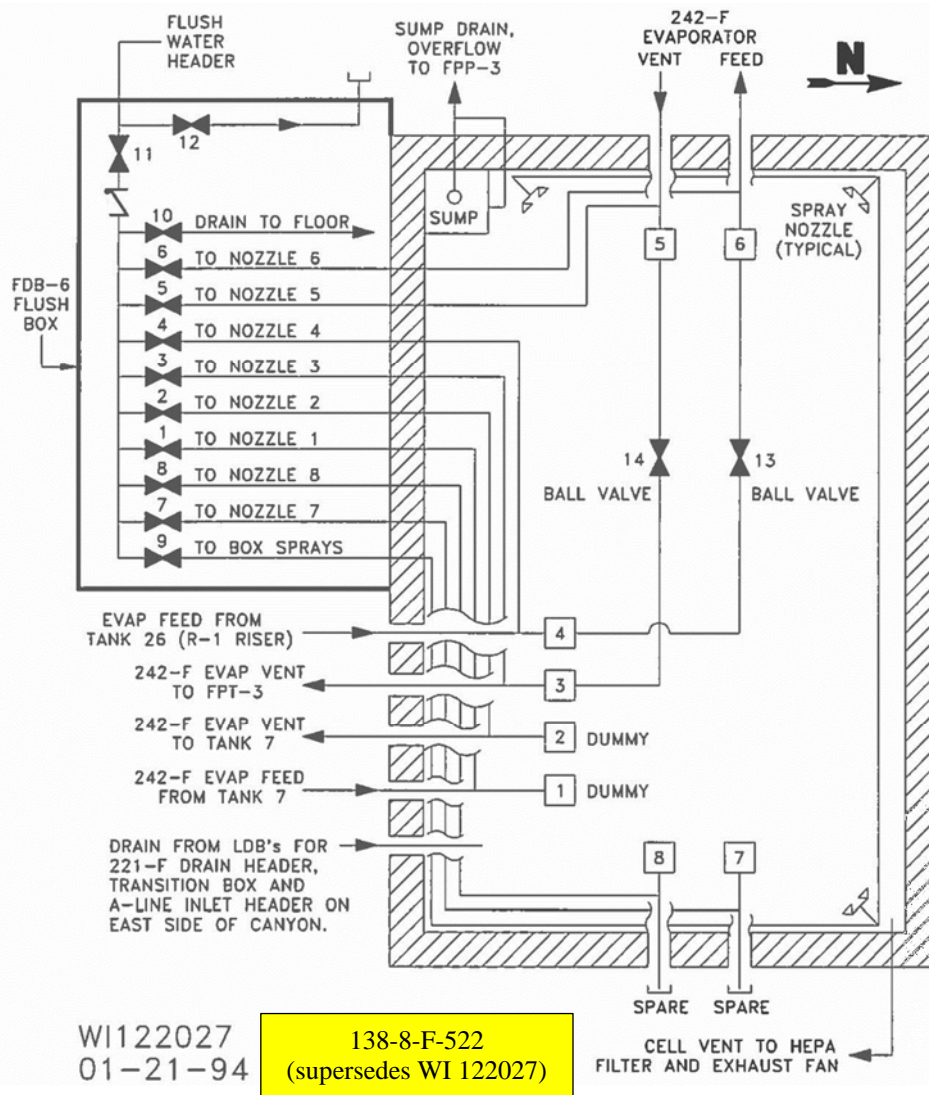

Table 2.6-1: Current Status of FDB-6 Waste Transfer Piping System

Nozzle Number	Purpose	Nozzle Status in FDB-6	Transfer Line Termination Status
1	Evaporator feed from Tank 7F, Riser 1	Dummy Hanford Connector	Tank 7F Riser 1
2	242-1F Evaporator vent line to Tank 7F	Dummy Hanford Connector	Tank 7F wall penetration
3	242-1F Evaporator vent line to FPT-3	Jumpered to Nozzle 5	Connected to FPP-3, Nozzle 3
4	Evaporator feed from Tank 26F	Jumpered to Nozzle 6	Tank 26F Riser 1
5	242-1F Evaporator vent line	Jumpered to Nozzle 3	Capped in 242-1F Evaporator cell
6	Feed to 242-1F Evaporator	Jumpered to Nozzle 4	Capped in 242-1F Evaporator cell
7	Spare	Dummy Hanford connector	Capped at FDB-6
8	Spare	Dummy Hanford connector	Capped at FDB-6

[after M-M6-F-3357]

Table 2.6-2: Additional FDB-6 Vault Piping System Lines

Pipe Size (I.D. Inches)	Purpose
6	Ventilation Duct
1	From LDB-1
1	From LDB-2
1	Clean-out drain line to sump drain line
4	Sump drain system to FPP-3
1	Sump overflow line
1	Instrument air (3 lines)
1	Drain from LDBs at 221-1F header, transition box, and A-Line inlet header at F-Canyon
0.75	Flush water supply lines

[after M-M6-F-3357]

2.7 FDB-6 Operational History

FDB-6 was constructed in the mid-to-late 1970s to transfer feed material to the 242-1F Evaporator from Tanks 26F and 7F. The transfers through FDB-6 were only supernate (evaporator feed). No “fresh canyon waste” or “sludge slurry” were sent through FDB-6. FDB-6 usage stopped when the 242-1F evaporator went out of service in 1988.

Cracking of the asphalt surrounding FDB-6 along with a process air line failure indicated poor soil compaction around the FDB-6 vault that was confirmed by testing. From September 15 to October 17, 1981, the soil surrounding FDB-6 was excavated and then returned with controlled compaction. [DPSP 81-21-10]

FDB-6 is currently inactive.

2.7.1 FDB-6 Leakage and Decontamination History

In March 1979, after hydrotesting of the feed line from FDB-6 to the 242-1F Evaporator, contaminated water (1,236 d/m/ml beta-gamma) was found in the FDB-6 sump. Smearable contamination on the walls was <500 d/m alpha and <1,000 c/m beta-gamma. The source appeared to be leakage from a dummy Hanford connector inside the vault. Decontamination of the vault reduced the transferable contamination to <10 c/m beta-gamma. [DPSP 79-21-3] The installed FDB-6 leak detection system performed as designed and there was no indication by the system of any liquid getting beyond the stainless-steel liner. Therefore, there would have been no reason to believe any material reached the surrounding soil.

In December 1979, 10 inches of water were drained from the FDB-6 sump. Samples measured <4,000 d/m/ml, and the source was suspected to be rainwater. The sump level was monitored to determine if water level increases correlated with tank farm conditions and activities. [DPSP 79-21-12]

No other leakage events inside FDB-6 have been reported. [SRR-CWDA-2018-00059] However, as described below, a small amount of unknown material was observed on the vault floor by Nozzle 3 during the July 13, 2018, camera inspection.

2.8 FDB-6 Inspections

Three video camera inspections have been performed on FDB-6. The most thorough inspection occurred on July 13, 2018. The second inspection, on August 31, 2019, focused on the valve box to verify that the opening for the flush water piping into FDB-6 was an open slot. The third inspection, on December 7, 2019, was to confirm that Nozzles 7 and 8 were sealed with dummy Hanford connectors.

July 13, 2018 Inspection

A video camera was inserted through the most northerly riser on the vault top. This inspection focused on the vault walls, floor area, and sump. Figure 2.8-1 shows various views of the FDB-6 interior.

The floor appears to be free of residual material except for two areas where anomalous material was found. Figure 2.8-2 shows the sump area with a small globule of shiny, black material near the southeast edge of the sump screen. The physical appearance of the material suggests that it might possibly be a glue-like material or mastic used to attach a gasket sealing the perimeter space between the vault and the cell covers and on the horizontal, interlocking surfaces running the length of the cell covers. It does not appear to be residual sludge material. [V-18-0439] The appearance is also not consistent with the waste (i.e., supernate) transferred through the diversion box. [U-ESR-F-00092]

A small deposit of material resembling crystallized salt (supernate) was seen on the vault floor near Nozzle 3 (Figure 2.8-3). It is most likely from a leak at Nozzle 4. [U-ESR-F-00092]

Figures 2.8-4 and 2.8-5 show an object laying beneath a Hanford connector on a disconnected jumper in the northern region of the vault. A close-up shows it resembles a degraded piece of plastic, most likely a “Rad bag” fragment (plastic bag used to hold potentially contaminated equipment).

The July 2018 survey also confirmed two discarded jumpers on the vault floor. [V-18-0439]
No additional residual material was seen on the vault walls, floor, or sump during the July 2018 inspection.

August 31, 2019 Inspection

A video camera was inserted into the flush water valve box. This inspection confirmed that the opening for the flush water piping to enter the vault was not blocked or sealed off. [V-19-0946]

December 7, 2019 Inspection

A video camera was inserted into the diversion box through the riser used for the July 2018 inspection. This inspection confirmed that Nozzles 7 and 8 were capped with dummy Hanford connectors. [V-19-1125]

Figure 2.8-1: Views of the FDB-6 Vault Interior



Figure 2.8-2: View of the FDB-6 Vault Southwest Corner and Sump (July 2018)

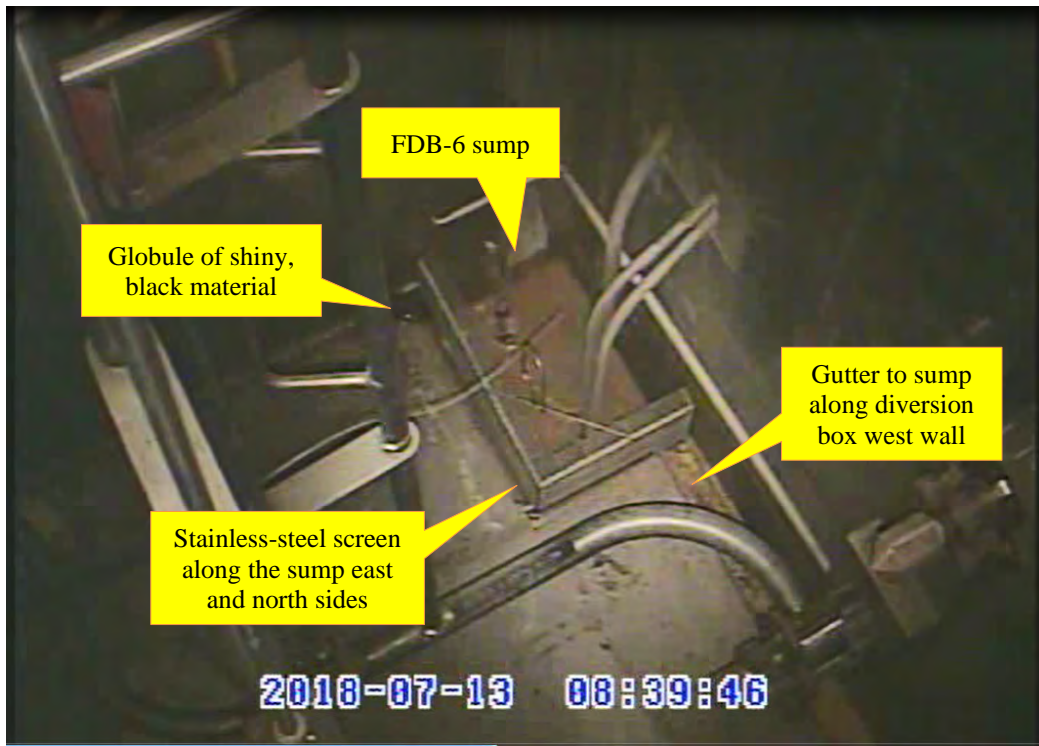

Figure 2.8-3: The Material (Salt) Deposit below Nozzle 4 in the Southeast Vault Region (July 2018)

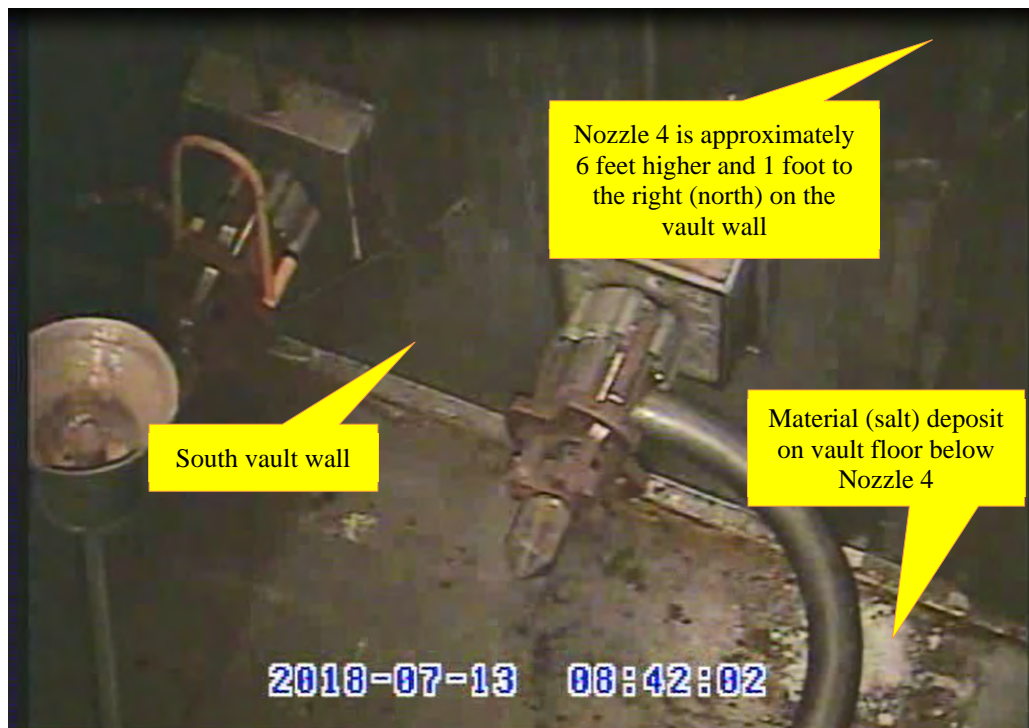

Figure 2.8-4: View of FDB-6 North Region Floor Showing Discarded Plastic beneath a Disconnected Hanford Connector (July 2018)

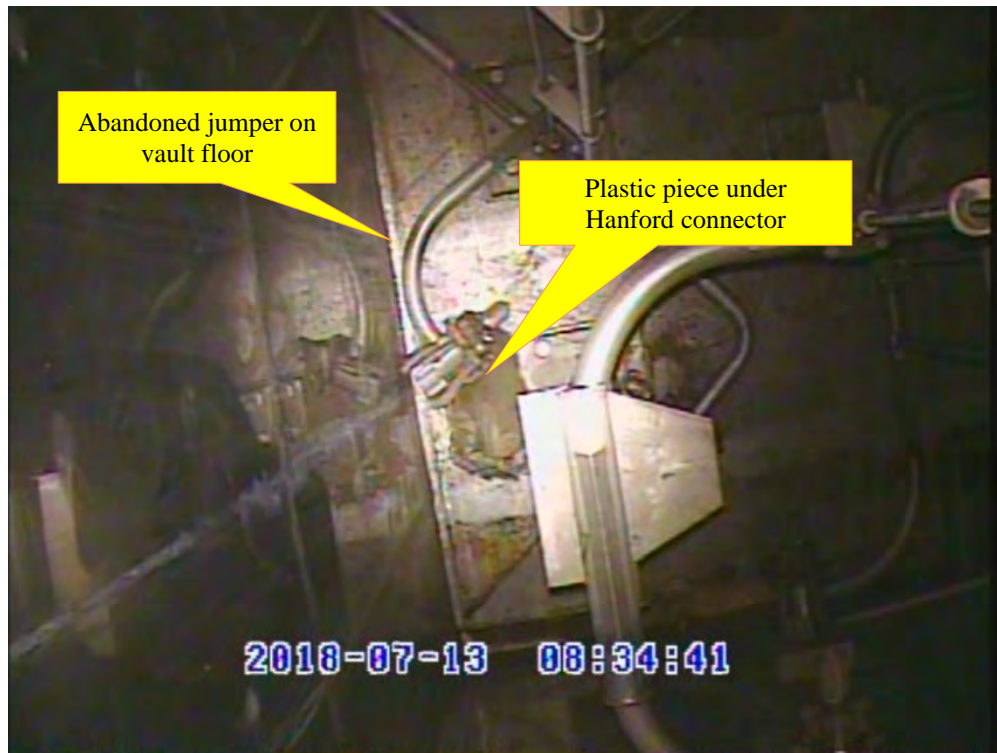

Figure 2.8-5: Close-up of Plastic Piece on FDB-6 Vault Floor (July 2018)



3.0 FDB-5 AND FDB-6 WASTE REMOVAL

As shown by the individual camera inspections, with the exception of a potential small salt deposit in FDB-6, there are no accumulated solids in either FDB-5 or FDB-6.

Because the FDB-5 transfer lines were typically flushed several times with clean water after each transfer, only minimal, if any, waste might be present inside the jumpers. [SRR-CWDA-2020-00029] The only residual material possibly inside the FDB-5 vault would have resulted from jumper cleaning. Because the waste was highly-soluble salt, and the vault was washed down after jumper cleanings, only minimal residual material might remain on the interior vault surfaces, and inside the sump drain line piping.

Because the FDB-6 transfer lines were also typically flushed several times with clean water after each transfer, only minimal, if any, waste might be present inside the jumpers. The only residual materials inside the FDB-6 vault is the minimal residual material remaining on the interior vault surfaces, inside the sump drain line piping, and the small deposit below Nozzle 4.

3.1 FDB-5 Waste Removal

Aside from the jumper cleanings, FDB-5 has had no known waste leakage or spillage events. [SRR-CWDA-2018-00059]

The waste generated during the jumper flushings and vault wash down activities, and any subsequent wall and floor washing, was drained to FPP-2 via the sump. No additional vault cleaning has been performed since FDB-5 use was discontinued in September 1985.

3.2 FDB-6 Waste Removal

Following the March 1979 detection of contaminated water in FDB-6, the vault was decontaminated. [DPSP 79-21-3] The report does not mention the decontamination method used, but the waste water was probably drained via the sump to FPP-3. Similarly, the water detected in December 1979 was also drained via the sump to FPP-3. [DPSP 79-21-12] No other waste leakage or water intrusion records or reports have been located.

No additional vault cleaning has been performed since FDB-6 use was discontinued in 1988.

As explained in Section 6.0, there are no plans to remove the globule of material by the sump or the small material deposit on the vault floor below Nozzle 4.

3.3 Residual Material Volume Estimate

Camera inspections of the two DBs are summarized in Section 2.0. The FDB-5 inspection determined there was no visible residual material inside the vault. [U-ESR-F-00094] Trained personnel from SRR Engineering performed a volume determination using the processes described in *Tank Mapping Methodology* (SRR-LWE-2010-00240) for the small deposit of material on the vault floor below Nozzle 4 and estimated it had a volume of 0.3 gallons (with an uncertainty range of 0.1 to 0.6 gallons). [U-ESR-F-00092]

3.4 Basis to Proceed to Sampling and Analysis Phase in FDB-5 and FDB-6

As described in the FDB-5 and FDB-6 Sample Location Determination Reports (SLDRs), except for the approximately 0.3 gallons of what is assumed to be crystallized salt in FDB-6,

no other waste was observed in either DB. [SRR-CWDA-2020-00024, SRR-CWDA-2020-00033] Any potentially remaining residual materials on the interior vault and jumper surfaces that have contacted waste, would be extremely difficult to remove or sample and would not justify a characterization effort and cost. Any anticipated SA and PA modeling impacts can be addressed without sampling by assigning a conservative and bounding inventory to the DBs as explained in the *Inventory Assignment at Closure for FDB-5 and FDB-6* (SRR-CWDA-2020-00029).

On July 13, 2020, Savannah River Remediation (SRR) presented the *Proposal to Cease Waste Removal Activities in F-Area Diversion Boxes 5 and 6* (SRR-CWDA-2020-00059) to DOE, SCDHEC, and EPA. The proposal focused on the inspections and visual evidence showing there is no significant amount of residual material remaining inside either FDB-5 or FDB-6.

SRR also proposed developing assigned radiological and chemical constituent inventories for FDB-5 and FDB-6 as allowed by the *Consolidated General Closure Plan for F-Area and H-Area Waste Tank Systems* (SRR-CWDA-2017-00015). The assigned inventories would then be used in the SA and other modeling efforts.

3.5 Agreement to Proceed to Sampling and Analysis Phase

Following the cease waste removal presentation, DOE sent the formal *Request for Concurrence to Proceed to Sample and Analysis Phase of the Closure Process for F-Area Diversion Boxes (FDB) 5 and 6 (SEMS Number: 23)* to SCDHEC and EPA. [WDPD-20-37] In response, SCDHEC and EPA sent concurrence letters approving the request to enter the sampling and analysis phase of the closure process for FDB-5 and FDB-6. [SRR-OS-2020-00309, SRR-OS-2020-00331]

4.0 RESIDUAL MATERIAL CHARACTERIZATION

The FTF PA did not assign a residual material inventory to either FDB-5 or FDB-6 because neither DB served as a primary waste containment structure. The PA also assumed the DBs contained a negligible inventory relative to other nearby significant inventory sources such as the waste tanks. [SRS-REG-2007-00002]

Because of their operating and leakage history, residual materials inside FDB-5 and FDB-6 could be present as a visible deposit and as a residue on the jumper interiors and vault interior surfaces such as the floor, sump, and walls. The surface residues, and any visible residual materials, would be the contributors to the total DB inventory.

The *Liquid Waste Tank Residuals Sampling and Analysis Program Plan* (LWTRSAPP) (SRR-CWDA-2011-00050) commits to characterizing residual materials remaining in a waste tank or ancillary structure being removed from service. However, as allowed in some instances by the LWTRSAPP and CGCP, and in consultation with the regulatory authorities, alternative actions, such as using process knowledge, can be used to determine an inventory for a waste tank or ancillary structure. [SRR-CWDA-2011-00050, SRR-CWDA-2017-00015]

4.1 FDB-5 and FDB-6 Inventory Determination Methodology

Details for the inventory assignment approach used for these DBs are presented in the *Inventory Assignment at Closure for FDB-5 and FDB-6* (SRR-CWDA-2020-00029). The approach used the same general methodology as the FTF PA to estimate the residual material inventory in the FTF transfer piping system. [SRR-REG-2020-00029, SRS-REG-2007-00002]

The FTF PA methodology assumed the transfer line internal surface contains residual material in three forms:

- Diffused into the metal,
- An oxide film coating, and
- Residue film remaining after a transfer and flush. [CBU-PIT-2005-00120]

The residual inventory was determined analytically and is considered to be reasonably bounding by assuming that residual material inside the jumpers accumulated in the same manner as residual material accumulated in the FTF transfer lines. While not directly analogous, the approach would also include (bound) the small globule of shiny black material, and the small deposit of material seen near Nozzle 3 on the FDB-6 floor during the visual inspection by assuming the vault floor and sump floor have the same residue. The approach would also ignore the inventory accumulated via diffusion into the metal or oxide film formed on steel surfaces since they are <1% compared to the residual inventory in the film remaining after flushing. [SRR-CWDA-2020-00029]

The FTF PA (Section 3.3) determined the surface concentrations (in curies and kilograms per square foot) for each of these three contributors based on representative dry sludge waste concentrations. Greater than 99% of the transfer line inventory contribution came from the residue film remaining after flushing. [SRS-REG-2007-00002]

The representative dry sludge concentration was determined by reviewing the waste transfers within FTF and between FTF and HTF using tank-specific transfer information and applying

a weighted average to each contaminant in the individual FTF waste tanks. Each tank's dry sludge concentrations were used in this determination. The final waste tank inventory values were based on data from the Waste Characterization System (WCS). WCS is an electronic information system that tracks waste tank data, including projected radionuclide and chemical inventories, based on sample analyses, process histories, composition studies, and theoretical relationships. [B-UG-H-00058]

The chemical and radionuclide Constituents of Concern (COCs) used for the inventory determination and in the SA were the same ones used in the FTF PA for ancillary equipment inventory estimation. [SRS-REG-2007-00002]

4.1.1 Inventory Calculation

Camera inspections confirmed that the vault and sump walls are clean, and except for the small material deposit in FDB-6, there are no visible material accumulations on the floor. Since the waste was highly soluble salt, after flushing there would only be minimal material possibly remaining on the vault floor, sump floor, and sump drain piping. Therefore, the vault and sump walls contribution to the inventory are assumed to be insignificant.

The total radiological and chemical inventory assigned to each diversion box was determined by multiplying the FTF PA calculated transfer line residue concentrations by the total affected diversion box surface area. A 4-inch I.D. transfer line surface concentration was chosen as the most conservative for the surface area calculation. Because the FTF transfer lines are predominantly 2-inch I.D., the use of a 4-inch I.D. line surface concentration increases the inventory. [SRR-CWDA-2020-00029] The affected area calculated used the internal surface area of the four transfer lines in each diversion box (two attached and two abandoned on the floor) and the diversion box floor area (neglecting the vault, sump, and gutter walls). The four jumpers in FDB-5 total 60.4 linear feet of pipe. The four jumpers in FDB-6 total 75 linear feet of pipe.

The formulas used for the concentration calculations are:

Radionuclides

Concentration (Ci) = (Affected surface area in ft²) x (Isotope concentration in Ci/ft²)

Chemicals

Concentration (kg) = (Affected surface area in ft²) x (Chemical concentration in kg/ft²)

The total affected surface area for FDB-5 is 182 ft² and for FDB-6 is 209 ft².

[SRS-CWDA-2020-00029]

4.1.2 Dry Sludge Concentrations Used for Inventory Calculation

The weighted "dry sludge" radionuclide and chemical constituent concentrations used for the FDB-5 and FDB-6 inventory calculation are presented in *Inventory Assignment at Closure for FDB-5 and FDB-6* (SRR-CWDA-2020-00029).

As previously discussed, no "fresh canyon waste" or "sludge slurry" were sent through either FDB-5 or FDB-6. Therefore, using the dry sludge concentrations provides a conservative representation of the actinides and long-lived isotopes that are important to the FTF PA. The short-lived isotopes that are more concentrated in supernate than sludge will decay quicker and

would not be significant dose contributors for the long-term impacts hundreds to thousands of years in the future.

In addition, the concentrations are decayed only to September 30, 2020, consistent with the FTF closure date assumed in the FTF PA. The date of FTF closure will be later causing some of the radionuclides of interest (e.g., Cs-137, Sr-90) to be overrepresented in the FDB-5 and FDB-6 inventory because additional decay between 2020 and the date of actual FTF closure is not accounted for.

The conservative nature of this inventory approach is also indicated by the fact that the assigned inventory for FDB-5 contains significantly more radioactivity than would be indicated by the two surveys of FDB-5 performed in 2020. The maximum radioactivity detected during the two surveys correlated to $5.0\text{E-}04$ Ci/ft² beta-gamma and $2.5\text{E-}08$ Ci/ft² alpha. For comparison, the FDB-5 inventory assignment based on the transfer line concentrations calculated in the FTF PA (Table 3.3-11) had $4.07\text{E-}02$ Ci/ft² for Sr-90 (the primary beta-gamma source) and $2.38\text{E-}04$ Ci/ft² for Pu-238 (the primary alpha source). [SRS-REG-2007-00002] The survey readings would be much higher if the assigned inventory were actually present.

4.2 FDB-5 Assigned Inventory

As mentioned earlier, the *F Area Diversion Box #5 Final Volume Determination and Uncertainty Estimate* (U-ESR-F-00094) determined there were no residual materials visible inside FDB-5.

The methodology used to calculate the FDB-5 inventory is presented in Section 4.1. The final FDB-5 assigned inventory is presented in Tables 4.2-1 and 4.2-2.

Table 4.2-1: FDB-5 Assigned Radionuclide Inventory (Decayed to September 30, 2020)

Radionuclide	Inventory (Ci)	Radionuclide	Inventory (Ci)	Radionuclide	Inventory (Ci)
Ac-227	1.81E-10	Eu-152	1.57E-03	Rh-106	3.51E-08
Al-26	1.76E-06	Eu-154	1.71E-02	Ru-106	3.51E-08
Am-241	1.38E-01	Eu-155	1.52E-02	Sb-125	9.66E-04
Am-242m	1.98E-04	H-3	1.93E-04	Sb-126	5.28E-05
Am-243	2.26E-05	I-129	1.68E-08	Sb-126m	3.77E-04
Ba-137m	1.29E+00	Na-22	2.77E-06	Se-79	2.00E-04
Bk-249	5.21E-31	Nb-94	8.92E-06	Sm-151	5.84E-01
C-14	1.01E-05	Ni-59	3.97E-04	Sn-126	3.77E-04
Ce-144	4.51E-10	Ni-63	3.29E-02	Sr-90	7.41E+00
Cf-249	1.91E-22	Np-237	1.87E-05	Tc-99	3.55E-03
Cm-242	5.70E-22	Pa-231	7.39E-09	Te-125m	2.37E-04
Cm-243	3.33E-06	Pm-147	1.48E-02	Th-229	1.19E-05
Cm-244	6.39E-03	Pr-144	4.51E-10	Th-230	3.39E-05
Cm-245	8.19E-08	Pu-238	4.33E-02	U-232	1.76E-07
Cm-247	3.06E-20	Pu-239	1.70E-02	U-233	8.81E-05
Cm-248	7.04E-21	Pu-240	6.26E-03	U-234	5.66E-05
Co-60	5.51E-03	Pu-241	2.95E-02	U-235	6.70E-07
Cs-134	3.06E-06	Pu-242	5.15E-05	U-236	1.08E-06
Cs-135	3.88E-06	Pu-244	2.42E-08	U-238	3.31E-05
Cs-137	1.38E+00	Ra-226	3.40E-05	Y-90	7.41E+00

[SRS-CWDA-2020-00029]

Table 4.2-2: FDB-5 Assigned Chemical Inventory

Chemical	Concentration (kg)	Concentration (g)
Ag	1.93E-03	1.93
As	6.52E-05	0.0652
Ba	2.38E-03	2.38
Cd	6.77E-03	6.77
Cr	2.53E-03	2.53
Cu	1.29E-03	1.29
F	1.75E-03	1.75
Fe	2.75E-01	275
Hg	1.84E-03	1.84
Mn	4.97E-02	49.7
Ni	2.00E-01	200
NO ₂ + NO ₃	2.29E-01	229
Pb	1.41E-02	14.1
Sb	1.56E-03	1.56
Se	2.00E-04	0.20
U	1.08E-01	108
Zn	2.40E-03	2.40

[SRS-CWDA-2020-00029]

4.3 FDB-6 Assigned Inventory

As mentioned earlier, the *F Area Diversion Box #6 Final Volume Determination and Uncertainty Estimate* (U-ESR-F-00092) estimated there were 0.3 gallons of what appeared to be salt waste under the area of Nozzle 4 inside the vault.

The methodology used to calculate the FDB-6 inventory is presented in Section 4.1. The dry sludge volume calculated for the affected FDB-6 area is assumed to conservatively bound the 0.3 gallons of visible waste on the floor beneath Nozzle 4 and the small globule of shiny black material near the sump screen. The final FDB-6 assigned inventory is presented in Tables 4.3-1 and 4.3-2.

Table 4.3-1: FDB-6 Assigned Radionuclide Inventory (Decayed to September 30, 2020)

Radionuclide	Inventory (Ci)	Radionuclide	Inventory (Ci)	Radionuclide	Inventory (Ci)
Ac-227	2.08E-10	Eu-152	1.80E-03	Rh-106	4.03E-08
Al-26	2.03E-06	Eu-154	1.96E-02	Ru-106	4.03E-08
Am-241	1.59E-01	Eu-155	1.75E-02	Sb-125	1.11E-03
Am-242m	2.28E-04	H-3	2.22E-04	Sb-126	6.06E-05
Am-243	2.59E-05	I-129	1.93E-08	Sb-126m	4.33E-04
Ba-137m	1.48E+00	Na-22	3.18E-06	Se-79	2.30E-04
Bk-249	5.98E-31	Nb-94	1.02E-05	Sm-151	6.71E-01
C-14	1.16E-05	Ni-59	4.56E-04	Sn-126	4.33E-04
Ce-144	5.18E-10	Ni-63	3.78E-02	Sr-90	8.51E+00
Cf-249	2.19E-22	Np-237	2.15E-05	Tc-99	4.08E-03
Cm-242	6.54E-22	Pa-231	8.49E-09	Te-125m	2.72E-04
Cm-243	3.82E-06	Pm-147	1.69E-02	Th-229	1.36E-05
Cm-244	7.34E-03	Pr-144	5.18E-10	Th-230	3.89E-05
Cm-245	9.41E-08	Pu-238	4.97E-02	U-232	2.02E-07
Cm-247	3.51E-20	Pu-239	1.96E-02	U-233	1.01E-04
Cm-248	8.09E-21	Pu-240	7.19E-03	U-234	6.50E-05
Co-60	6.33E-03	Pu-241	3.39E-02	U-235	7.69E-07
Cs-134	3.51E-06	Pu-242	5.91E-05	U-236	1.24E-06
Cs-135	4.45E-06	Pu-244	2.78E-08	U-238	3.80E-05
Cs-137	1.59E+00	Ra-226	3.91E-05	Y-90	8.51E+00

[SRS-CWDA-2020-00029]

Table 4.3-2: FDB-6 Assigned Chemical Inventory

Chemical	Concentration (kg)	Concentration (g)
Ag	2.22E-03	2.22
As	7.48E-05	0.075
Ba	2.74E-03	2.74
Cd	7.77E-03	7.77
Cr	2.91E-03	2.91
Cu	1.48E-03	1.48
F	2.01E-03	2.01
Fe	3.16E-01	316
Hg	2.11E-03	2.11
Mn	5.71E-02	57.1
Ni	2.30E-01	230
NO ₂ + NO ₃	2.63E-01	263
Pb	1.62E-02	16.2
Sb	1.79E-03	1.79
Se	2.30E-04	0.23
U	1.24E-01	124
Zn	2.76E-03	2.76

[SRS-CWDA-2020-00029]

4.4 Assigned Inventory Conservatism

Using an approach like the one used for the transfer line inventory estimation in the FTF PA results in several conservatisms for the inventories assigned to FDB-5 and FDB-6:

- The radiologic and chemical inventories assigned to FDB-5 and FDB-6 conservatively assume material presence on the DB surfaces (jumper internals and vault floors) equivalent to approximately five gallons of residual material. [SRR-CWDA-2020-00029] Camera inspections confirmed that the vault and sump walls are clean with no residual material visible in FDB-5 and only an estimated 0.3 gallons of material on the FDB-6 floor. [U-ESR-F-00092, U-ESR-F-00094]
- The calculated concentrations used in the inventory assignment are decayed only to September 30, 2020, consistent with the closure date assumed in the FTF PA. The actual closure date will be later resulting in some of the radionuclides of interest (Cs-137, Sr-90) being overrepresented in the inventories because additional decay before the actual FTF closure is not accounted for.
- The transfers through FDB-5 and FDB-6 were only supernate (evaporator feed and concentrated supernate), not sludge slurry. If the calculated concentrations used dried salt, the inventories would contain significantly less long-lived transuranic radionuclides of concern.

- The assigned inventory for FDB-5 contains significantly more radioactivity than would be indicated by the two surveys performed in 2020. The maximum radioactivity detected during the two surveys was $5.0\text{E-}04$ Ci/ft² beta-gamma and $2.5\text{E-}08$ Ci/ft² alpha. For comparison, the FDB-5 inventory assignment based on the transfer line concentrations calculated in the FTF PA (Table 3.3-11) had $4.07\text{E-}02$ Ci/ft² for Sr-90 (the primary beta-gamma source) and $2.38\text{E-}04$ Ci/ft² for Pu-238 (the primary alpha source). [SRS-REG-2007-00002] The survey readings would be much higher if the assigned inventory were actually present.

5.0 PERFORMANCE EVALUATION

Background

The FTF PA was prepared to support closure of the FTF underground radioactive waste tanks and ancillary structures. The FTF PA purpose is to evaluate the potential impact on human health and the environment by modeling the residual contaminant release from waste tanks and ancillary structures that have been stabilized with grout. Therefore, the assumed inventory of contaminants is the starting point for modeling the contaminant release.

A methodical approach was used to construct projections of FTF waste tank system closure inventories to be used in the PA modeling. This approach considered current tank inventories, uncertainties in the effectiveness of tank cleaning technologies, laboratory detection limits, decay products, and radionuclide half-lives. The current FTF inventory projection is provided in *F-Tank Farm Closure Inventory for Use in Performance Assessment Modeling*. [SRR-CWDA-2009-00045]

As mentioned previously, no inventory was assigned to FDB-5 or FDB-6 in the FTF PA because neither diversion box served as a primary waste containment structure. Their assumed inventory was considered negligible relative to other nearby significant inventory sources like the waste tanks. [SRS-REG-2007-00002] However, the FDB-5 and FDB-6 assigned inventories represent an increase relative to the FTF PA and supporting Special Analyses.

5.1 FDB-5 and FDB-6 Special Analysis

The purpose of the FDB-5 and FDB-6 Special Analysis (SA) is to evaluate the information regarding the final residual inventories that are planned to be grouted in-place in FDB-5 and FDB-6. This new inventory information was used to update select portions of the FTF fate and transport modeling performed in the FTF PA and its supporting Special Analyses (i.e., the Tank 18/19 SA [SRR-CWDA-2010-00124] and the Tank 5/6 SA [SRR-CWDA-2012-00106]). The potential impacts of the new inventory information on the assumptions from the FTF PA and supporting Special Analyses were also considered.

The FTF PORFLOW flow and transport model was not changed for the modeling runs performed for the SA except to add the FDB-5 and FDB-6 inventories. The FTF PORFLOW model was rerun with the assigned FDB-5 and FDB-6 inventories to provide 1-meter and 100-meter radiological concentrations. No PORFLOW deterministic sensitivity runs were performed.

As a result of the small residual inventories and associated low doses, no FTF probabilistic GoldSim modeling was performed for this SA.

The SA results are summarized below. Full details are presented in the *FDB-5 and FDB-6 Special Analysis for the Performance Assessment for the F-Tank Farm at the Savannah River Site* (SRR-CWDA-2020-00055).

5.2 Assessment Evaluation

The potential impacts of the new inventory information on the assumptions in the FTF PA and supporting SAs were evaluated and many were found to be unchanged. A summary of those other impacts evaluated using the estimated FDB-5 and FDB-6 inventories are:

- The SRS site characteristics information is not affected.
- The FTF facility design information is not affected.
- The FTF waste tank inventories are not affected.
- The FTF analysis of performance (overview of analysis, source term release) is not affected.
- The closure system modeling information is not affected.
- The biotic pathways calculations are not affected.
- The airborne and radon pathway conceptual model and analysis approach is not affected.
- The bioaccumulation factors and human health exposure parameters are not affected.
- The dose analysis information is not affected.
- The “As Low As Reasonably Achievable” (ALARA) information is not affected.
- The FTF Contaminant Migration Constituents of Concern (CMCOCs) identified in the Tank 5/6 SA are not impacted.
- The uncertainty analyses and sensitivity analyses information presented in the FTF PA and its supporting SA are not affected.
- Because the peak flows release rates (fluxes) are waste tank fluxes (which are not affected by the new FDB-5 and FDB-6 information and did not change) the FTF PA peak flux information has not been updated.
- The Member of the Public (MOP) peak dose analysis information is not affected.

Additional information on these individual evaluations is in the *FDB-5 and FDB-6 Special Analysis for the Performance Assessment for the F-Tank Farm at the Savannah River Site* (SRR-CWDA-2020-00055).

5.3 Groundwater Evaluation

Section 4.3 of FTF PA contains a discussion of the modeling codes. The FTF PA Base Case (i.e., deterministic) modeling was performed using the same flow and transport model that was used in the FTF PA, Rev. 1 and its supporting SAs. The FTF PORFLOW flow and transport model was not changed for this SA except to add the FDB-5 and FDB-6 inventories. The FTF PORFLOW model was rerun with the new FDB-5 and FDB-6 inventories to provide 1-meter and 100-meter radiological concentrations. No PORFLOW deterministic sensitivity runs were performed.

The FTF GoldSim flow and transport model was not changed for the SA modeling runs except to add the FDB-5 and FDB-6 inventories to provide radiological concentrations. As a result of the small residual inventories and associated low doses, no FTF probabilistic GoldSim modeling was performed for this SA.

Maximum groundwater concentrations were generated for the exposure points:

- 1) 100-meters from the FTF, and
- 2) The Upper Three Runs (UTR) and Fourmile Branch (FMB) seeplines.

The 100-meter groundwater concentrations were calculated for the FTF PA Base Case using only the revised FDB-5 and FDB-6 inventories to see their impact. Calculations were performed using both the GoldSim FTF and PORFLOW FTF models. [SRR-CWDA-2020-00055]

5.3.1 Groundwater Concentrations at the Seepines

Because the peak seepine concentrations are dominated by waste tank releases and are unchanged by the new FDB-5 and FDB-6 information, the seepine groundwater concentrations did not require updating. The UTR and FMB seepine groundwater concentrations calculated in the Tank 5/6 SA remain the peak seepine groundwater concentrations. [SRR-CWDA-2012-00106]

5.3.2 MOP Exposure Dose Analysis

Peak doses have been recalculated using only the FDB-5 and FDB-6 peak groundwater concentrations identified in Section 6.3.2 of the SA using the PORFLOW FTF model for the FTF PA Base Case. [SRR-CWDA-2020-00055]

Table 5.3-1 shows a comparison of the 100-meter peak groundwater pathway doses (recalculated using the FDB-5 and FDB-6 FTF inventories) for the different 100-meter sectors (Figure 5.3-1) within 1,000 and 10,000 years. Table 5.4-1 also shows the 100-meter peak groundwater pathway doses from the *Tanks 5 and 6 Special Analysis for the Performance Assessment for the F-Tank Farm at the Savannah River Site* (SRR-CWDA-2012-00106) calculated using all the FTF inventories. In calculating the peak groundwater pathway dose, the highest radionuclide concentration within each sector's vertical computational mesh from the Upper Three Runs Aquifer (UTRA)-Upper Zone (UZ), UTRA-Lower Zone (LZ), and the Gordon Aquifer aquifers was used.

Figure 5.3-1 FTF 1-meter and 100-meter PORFLOW Model Evaluation Sectors

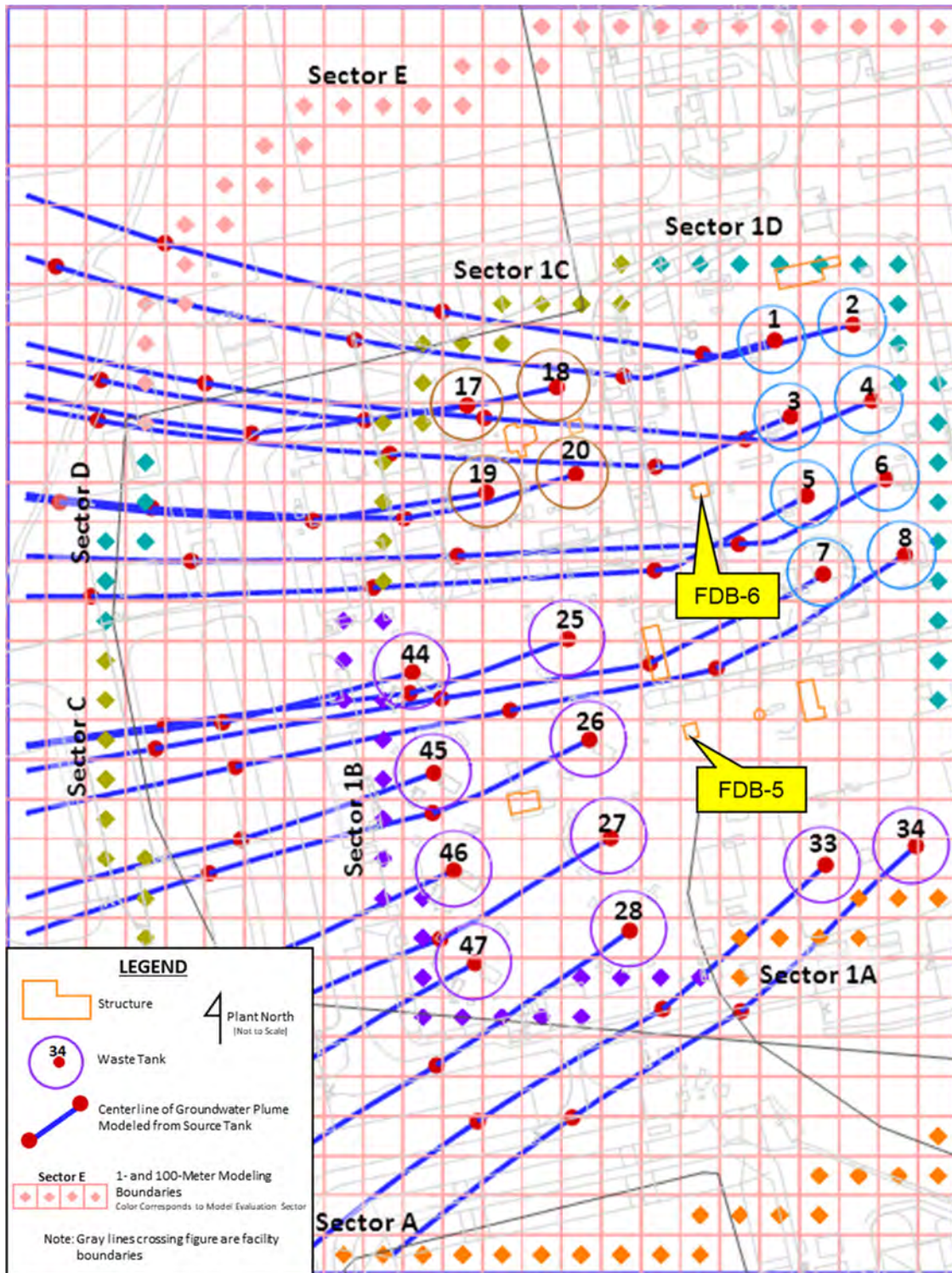

Table 5.3-1: 100-Meter MOP Peak Groundwater Pathways Dose by Modeling Sector

Sector	FTF Highest Peak Dose in 1,000 Years	FDB-5 Highest Peak Dose in 1,000 Years	FDB-6 Highest Peak Dose in 1,000 Years	FTF Highest Peak Dose in 10,000 Years	FDB-5 Highest Peak Dose in 10,000 Years	FDB-6 Highest Peak Dose in 10,000 Years
A	0.1 mrem/yr (year 752)	0.001 mrem/yr (year 724)	<0.001 mrem/yr	0.1 mrem/yr (year 752)	0.001 mrem/yr (year 724)	<0.001 mrem/yr
B	0.1 mrem/yr (year 754)	0.006 mrem/yr (year 722)	<0.001 mrem/yr	0.1 mrem/yr (year 754)	0.006 mrem/yr (year 722)	<0.001 mrem/yr
C	0.1 mrem/yr (year 740)	0.006 mrem/yr (year 720)	0.005 mrem/yr (year 724)	0.2 mrem/yr (year 4,306)	0.006 mrem/yr (year 720)	0.005 mrem/yr (year 724)
D	0.3 mrem/yr (year 704)	<0.001 mrem/yr	0.01 mrem/yr (year 720)	1.8 mrem/yr (year 6,056)	<0.001 mrem/yr	0.01 mrem/yr (year 720)
E	0.4 mrem/yr (year 704)	<0.001 mrem/yr	0.004 mrem/yr (year 720)	3.3 mrem/yr (year 10,000)	<0.001 mrem/yr	0.004 mrem/yr (year 720)

Note: Dose values are shown to two significant figures to illustrate changes/trends. The use of two significant figures is not meant to imply this level of precision for these dose projections.

The highest FDB-5 and FDB-6 related peak-groundwater pathway dose for both 1,000 and 10,000 years is 0.01 mrem/yr in Sector D and is associated with FDB-6 (Tc-99 contributes 50% of this peak). The 0.01 mrem/yr peak is significantly less than 100-meter peak groundwater pathway doses calculated for the entire FTF in 1,000 years (0.4 mrem/yr) and 10,000 years (3.3 mrem/yr). The FTF peak doses in 1,000 and 10,000 years are unchanged from the updated Base Case results previously reported in *Tanks 5 and 6 Special Analysis for the Performance Assessment for the F-Tank Farm at the Savannah River Site* (SRR-CWDA-2012-00106).

The highest FDB-5 associated peak-groundwater pathway dose within 1,000 years is approximately 0.006 mrem/yr in Sector C at year 720 and Sector B at year 722 (Table 5.3-1). Figure 5.3-2 shows the FDB-5 100-meter MOP receptor peak dose and doses within 10,000 years for the five 100-meter sectors.

The highest FDB-6 associated peak-groundwater pathway dose within 1,000 years is approximately 0.01 mrem/yr in Sector D at year 720 (Table 5.3-1). Figure 5.3-3 shows the FDB-6 100-meter MOP receptor peak dose and doses within 10,000 years for the five 100-meter sectors.

Figure 5.3-2: FDB-5 100-Meter MOP Peak Groundwater Pathway Dose within 10,000 Years for the Five 100-Meter Modeling Sectors

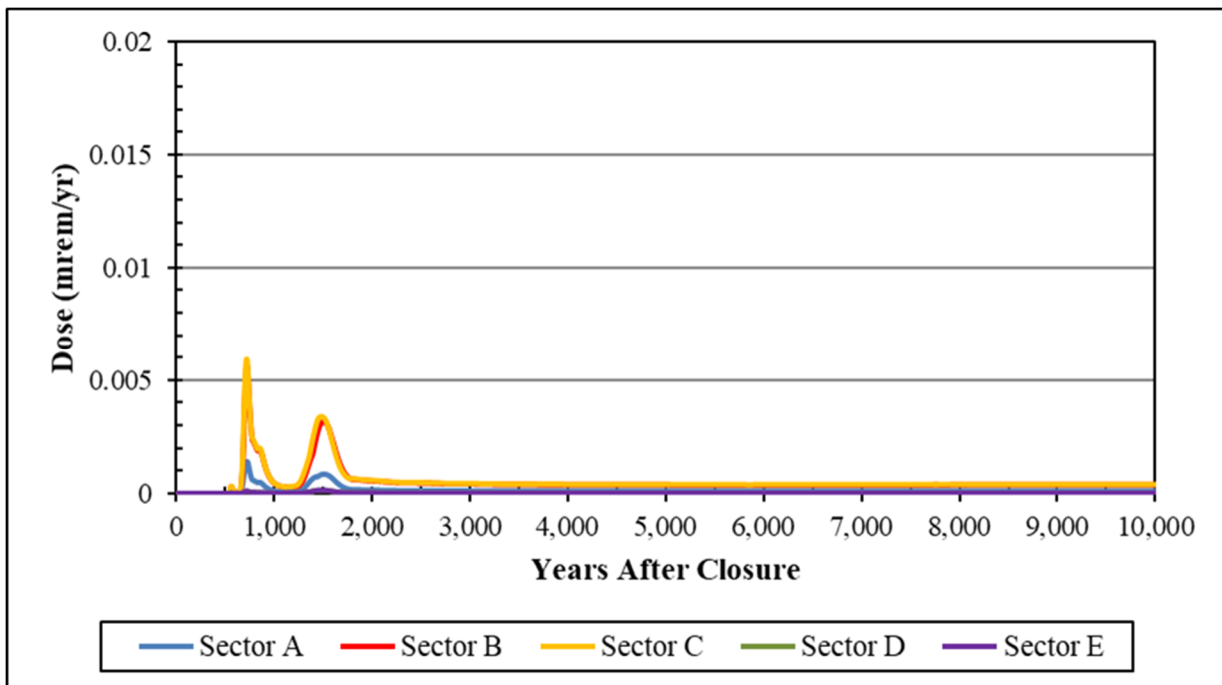
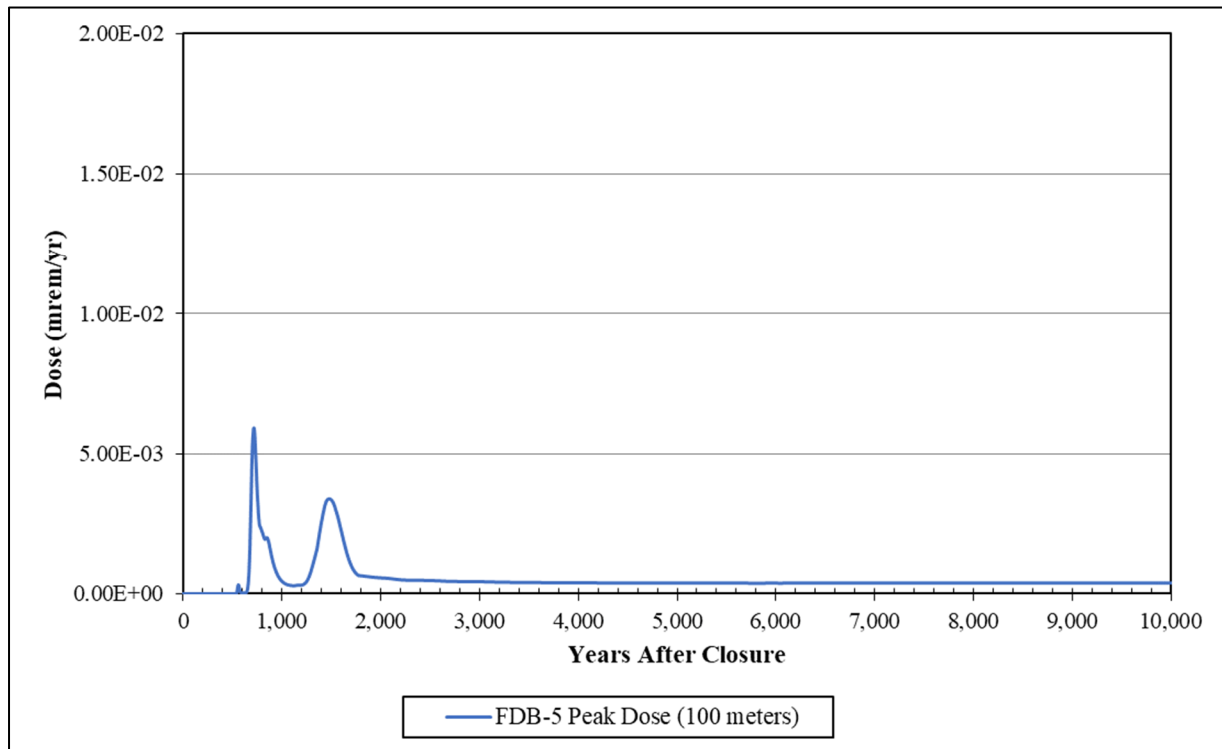
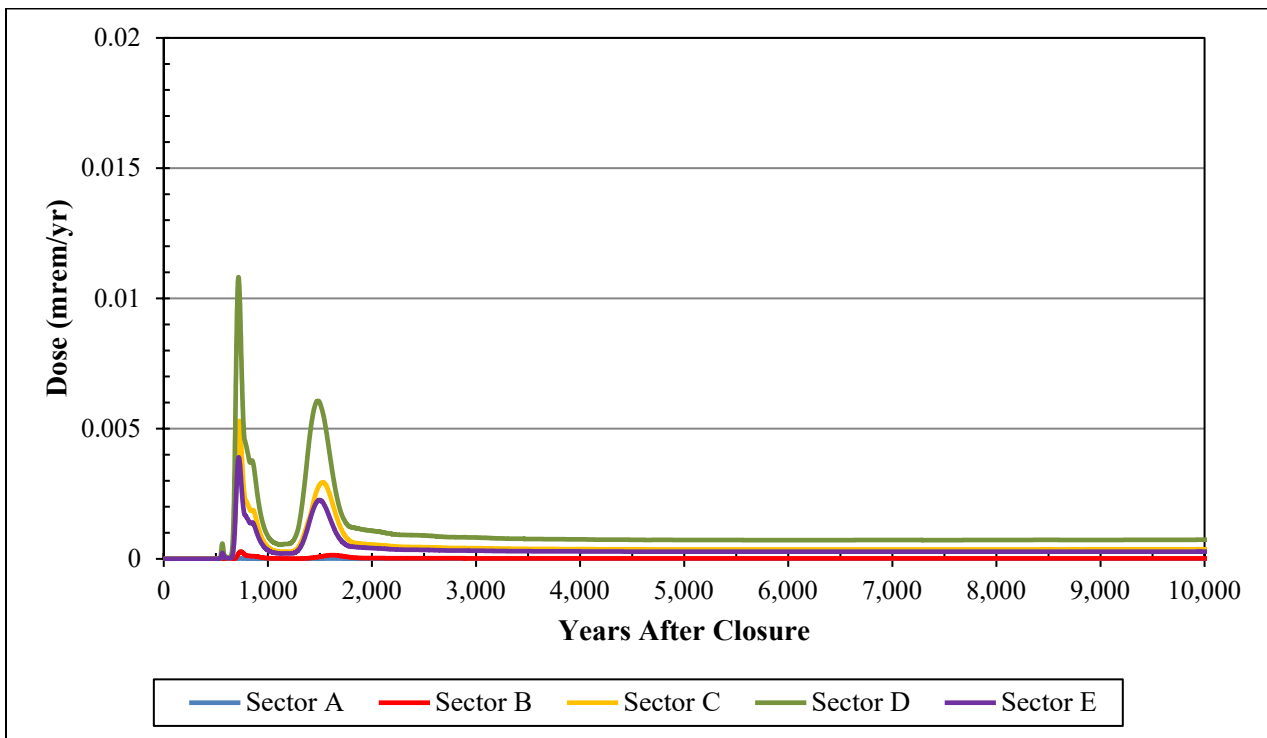
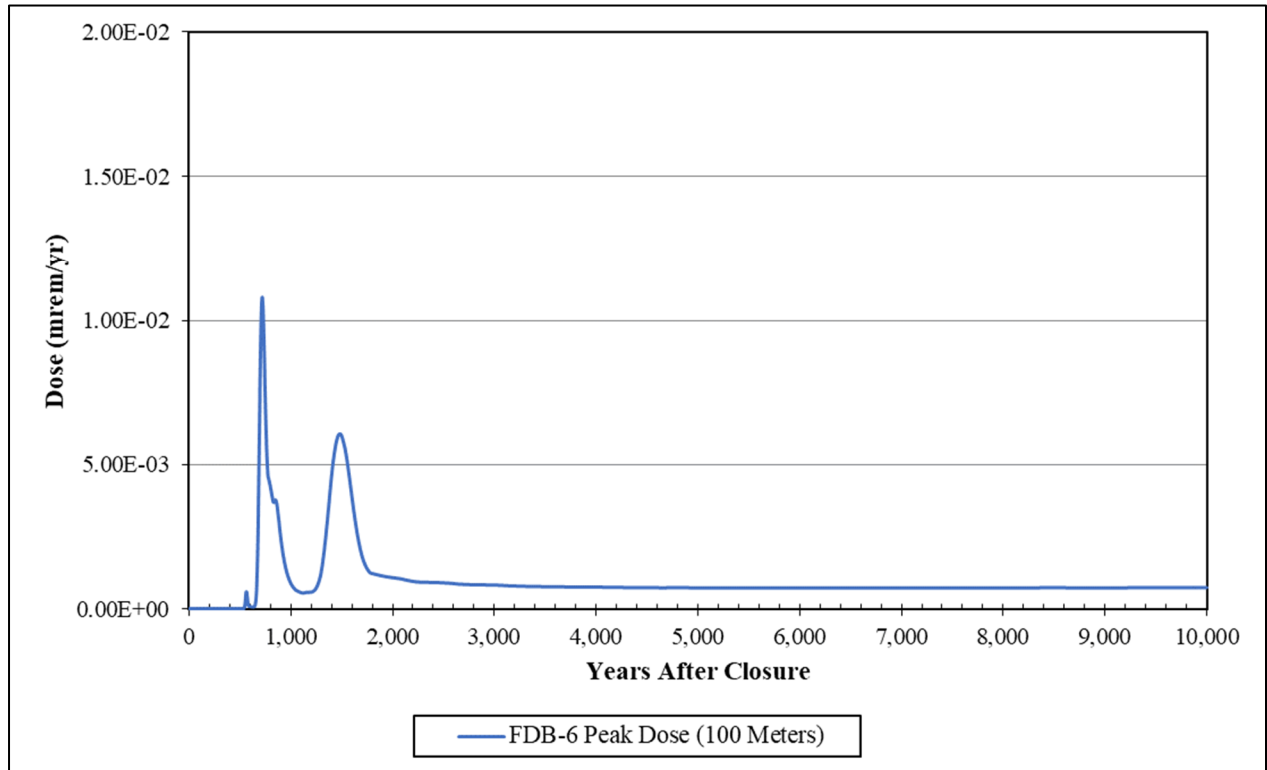

Figure 5.3-3: FDB-6 100-Meter MOP Peak Groundwater Pathway Dose within 10,000 Years for the Five 100-Meter Modeling Sectors



5.3.3 MOP Peak Groundwater and All-Pathways Dose at the Stream

The peak groundwater-pathway doses for the FMB and UTR seeplines were not recalculated for the updated FDB-5 and FDB-6 inventories based on the low 100-meter MOP doses in 1,000 years.

The peak all-pathways annual dose for the MOP at the stream is not impacted by the updated FDB-5 and FDB-6 inventories. The peak all-pathways annual dose for the MOP remains 3.3 mrem/yr as calculated in the *Tanks 5 and 6 Special Analysis for the Performance Assessment for the F-Tank Farm at the Savannah River Site* (SRR-CWDA-2012-00106) and is associated with Sector E.

5.4 RCRA/CERCLA Risk Analysis

The RCRA/CERCLA risk assessment for the FTF final facility closure follows the current SRS Area Completion Project protocols for human health and ecological risk assessments. The Tank 5/6 SA identified Np-237 and Tc-99 as CMCOCs based on the 1,000-year concentration curves and using the Savannah River Nuclear Solutions Area Completion Project protocols for human health and ecological risk assessments. These CMCOCs are not impacted by the assigned radiological inventories in either FDB-5 or FDB-6. [SRR-CWDA-2012-00106, SRR-CWDA-2020-00055]

The peak groundwater concentrations calculated using only the FDB-5 and FDB-6 radiological inventories are insignificant. The overall FTF peak radiological groundwater concentrations and CMCOCs identified in the Tank 5/6 SA remain overriding. [SRR-CWDA-2020-00055]

The Groundwater Chemical Concentrations at 1-meter from FTF were not revised to incorporate FDB-5 and FDB-6 because those chemical inventories were insignificant in comparison to individual waste tank inventories. No individual FDB-5 or FDB-6 chemical inventory was even 0.5% of the Tank 5F or Tank 6F chemical inventory, with most being less than 0.1%. Because the peak groundwater chemical contributions resulting only from the FDB-5 and FDB-6 chemical inventories are insignificant, the overall FTF peak chemical groundwater concentrations and CMCOCs identified in the Tank 5/6 SA remaining overriding. [SRR-CWDA-2020-00055] Accordingly, the groundwater radiological and chemical concentrations at 1-meter from the FTF remain accurate and did not need to be revised to incorporate the FDB-5 and FDB-6 inventories. [SRR-CWDA-2020-00055]

5.5 F-Tank Farm Interpretation of Results

Section 7.0 of FTF PA summarizes the conservatisms used in modeling and provides a summary and interpretation of the results presented in Section 5.0 and Section 6.0 of the FTF PA. The FTF PA conservatisms information are not affected by the new FDB-5 and FDB-6 assigned inventories. The individual dose results provided in the Section 7.1.2 of FTF PA and its supporting Special Analyses remain valid.

5.6 Conclusions

The FTF PA provides groundwater radionuclide concentrations at 1-meter, 100-meters, and at the two seepline exposure points approximately 1,600-meters from FTF. The groundwater concentrations are provided for each of the three aquifers as applicable as a part of the FTF

groundwater modeling. The FTF PA also provides groundwater concentrations for chemical contaminants at 1-meter and 100-meters. In addition, FTF PA provides intruder doses as well as analyses for the air pathways and radon ground surface flux. The FTF PA results can be used in subsequent documents to demonstrate compliance with the pertinent requirements identified below for final FTF facility closure as indicated in Table 5.6-1.

Table 5.6-1: Key Limits from Regulatory Requirements

Requirement	All-Pathways Dose	Intruder Dose	Air Pathway Dose	Radon Flux	Groundwater Protection
NDA Section 3116; 10 CFR 61.41 and 61.42	25 mrem/yr	500 mrem/yr	N/A	N/A	N/A
DOE M 435.1-1	25 mrem/yr	500 mrem – acute 100 mrem/yr – chronic	10 mrem/yr	20 pCi/m ² /s at ground surface	< MCL
SCDHEC Primary Drinking Water Regulations (SCDHEC R.61-58)	N/A	N/A	N/A	N/A	< MCL

N/A = Not Applicable

MCL = Maximum Contaminant Level

The key radiological results from the FTF PA and supporting SAs remain valid and are shown in Table 5.6-2. These results were not changed by the new FDB-5 and FDB-6 assigned inventories.

Table 5.6-2: Summary Radiological Results for F-Tank Farm

Location	Peak Within 10,000 Years (from the FTF PA and supporting SAs)		
	All-Pathways Dose (mrem/yr)	Groundwater Pathway Dose (mrem/yr)	Air Pathway Dose (mrem/yr)
100 meters from FTF	3.3 at ~ year 10,000	3.3 at ~ year 10,000	4.6E-06
At Seepline(s)	0.10 at ~ year 5,550	0.10 at ~ year 5,550	8.3E-07

Note Dose values are shown to two significant figures to illustrate changes/trends. The use of two significant figures is not meant to imply this level of precision for these dose projections.

Note The FTF PA, Rev.1 peak intruder dose is 73 mrem/yr at year 101 from a chronic scenario, drilling through a transfer line and using groundwater concentrations at the maximum 1-meter FTF location. This value is not changed in this Special Analysis.

Note The FTF PA peak radon flux at the ground surface is 3.6E-08 pCi/m²/s.

As reported previously in the *Tanks 5 and 6 Special Analysis for the Performance Assessment for the F-Tank Farm at the Savannah River Site* (SRR-CWDA-2012-00106), the peak groundwater radionuclide concentrations for Np-237 and Tc-99 were above the respective Preliminary Remediation Goal (PRG) or Maximum Contaminant Level (MCL) values at 1-meter; no PRG or MCL values were exceeded at 100-meters or at the seeplines. The peak concentrations for the

chemicals of concern were also calculated, and all were less than the MCL or Regional Screening Level (RSL) at 1-meter from FTF.

The groundwater acute and chronic exposure scenario information presented in the FTF PA are not significantly affected by the new FDB-5 and FDB-6 information.

The FTF peak groundwater radionuclide concentrations were not changed by the new FDB-5 and FDB-6 residual waste information. The groundwater chemical concentrations at 1-meter from the FTF were not revised to incorporate the FDB-5 and FDB-6 chemical inventories because they are insignificant in comparison to individual waste tank inventories.

The SA results provide reasonable assurance that compliance is maintained with the specific requirements of NDAA Section 3116, DOE M 435.1-1, and the MCLs. The results presented in the FTF PA and supporting SAs are not significantly impacted by the estimated residual inventories that will remain in FDB-5 and FDB-6 when they are filled with grout and removed from service. [SRR-CWDA-2020-00055]

6.0 ASSESSMENT OF THE IMPACT OF DEPLOYING ADDITIONAL WASTE REMOVAL TECHNOLOGY

The FDB-5 and FDB-6 structures served as secondary containment for the transfer lines (jumpers) that passed through them. As such, the DB's were not designed to serve as primary waste storage structures and therefore did not hold or store waste. As described in Sections 2.0 and 3.0, the only contact with waste was incidental as part of jumper cleaning in FDB-5, and inleakage of contaminated water from a hydrotest into FDB-6. Following these incidents, the DB's were decontaminated by washing down the interiors with clean water.

As expected, based on their operational histories, and as verified by video inspection, the structures do not contain accumulated solids on their interior surfaces. The only exception is the approximately 0.3 gallons of material on the FDB-6 floor which likely resulted from a small leak at a nozzle. Because only supernate was transferred through these DBs, it is presumed to be crystalized supernate. [U-ESR-F-00092, U-ESR-F-00094] Because the transfer lines were flushed with clean water after each transfer, only minimal, if any, waste might be present inside the jumpers. [SRR-CWDA-2020-00029]

As discussed in Section 5.0, to bound the impact of the assumed waste residue potentially present on the interior surface of the DBs or jumpers, a conservative inventory was assigned to each of the structures. Using the assigned inventory, an SA was performed to evaluate the potential risk to a future hypothetical member of the public (MOP). The SA estimated the maximum dose to a future hypothetical MOP resulting from the waste potentially in FDB-5 at 0.006 mrem/yr and from FDB-6 at 0.01 mrem/year. [SRR-CWDA-2020-00055]

This section presents an evaluation of the potential benefits resulting from further waste removal efforts in FDB-5 and FDB-6.

6.1 Analysis of Potential Cleaning Technologies

As required by the CGCP, DOE continues to provide an annual cleaning technology briefing to SCDHEC in a dedicated meeting. Meeting materials are provided to SCDHEC in a manner that can be referenced. These annual updates include information shared and lessons learned between DOE sites and recent and regular reports published under DOE's technology development program. The last briefing held was in November 2020. [SRR-LWE-2020-00095]

As discussed in the CGCP, there are three categories of cleaning technologies that could be deployed for additional waste removal in FDB-5 and FDB-6. These include:

- Mechanical cleaning,
- Chemical cleaning, and
- Vacuum removal technologies.

To be effective, any technology deployed would need to effectively remove the film coating potentially present on the vault floor and inside the abandoned and in-place jumpers that are assumed to contain the remaining residual material. [SRR-CWDA-2020-00029]

6.1.1 Mechanical Cleaning Technologies

Typical mechanical cleaning technologies used in waste removal within the waste tanks at SRS involve the addition of water or supernate to the waste tank and subsequent use of mixing devices and transfer pumps to agitate and/or recirculate the tank contents. The mixing/recirculating dissolves the soluble fraction of the waste and suspends accumulated solids so that they can be transferred out of the tank.

Because the DBs were cleaned by being sprayed down with water, it is uncertain if any additional benefit would be gained by mechanically mixing any added solution, except for potentially dissolving and removing the approximately 0.3 gallons of crystalized supernate in FDB-6.

To possibly improve waste removal efficiency over water washing, a mechanical cleaning approach would also need to incorporate a mechanical abrasion process such as brushing, scraping, or sandblasting the surfaces to remove any potential film. This approach would require development and testing for deployment of the technology, as well as removal of cell covers or core drilling a new, large access port for equipment deployment.

The effectiveness of deploying additional mechanical cleaning technology for potential waste residue removal on the DB's interior surfaces is uncertain. Deploying any mechanical cleaning technology with a mechanical abrasion process capable of cleaning the jumper interior surfaces would be very difficult and would require removing the DB cell covers to disconnect the in-place jumpers and access their, and the abandoned jumpers, internal surfaces.

6.1.2 Chemical Cleaning Technologies

Chemical cleaning using oxalic acid (OA) and/or Low Temperature Dissolution (LTAD) has been utilized for waste tank cleaning at SRS. The LTAD process is a cleaning technique applicable to sludge waste that is high in aluminum content. As discussed in Section 2.0, FDB-5 or FDB-6 were not used for any sludge slurry transfers and there would be no practical reason to use the LTAD process on them. The OA cleaning process would require adding OA into the DBs to a level that would fully submerge the abandoned jumpers on the floor. Typically, OA cleaning also incorporates agitation to facilitate acid contact so OA cleaning would also require development of a mixing device to agitate and /or recirculate the cleaning solution.

The effectiveness of using a chemical cleaning technology to remove any potential waste residue on the DB interior surfaces is uncertain. Chemical cleaning could potentially remove some waste residue from inside the abandoned jumpers, but without opening the DB and removing the in-place jumpers, chemical cleaning would not remove any potential residue within the in-place jumpers. Because the small deposit remaining in FDB-6 is assumed to be soluble salt material, it is possible that chemical cleaning would be effective at removing that material.

6.1.3 Vacuum Cleaning Technologies

With the exception of the small deposit in FDB-6, the DBs do not have any accumulated solids, so the benefit of deploying a vacuum technology is uncertain. The vacuum technology previously used to remove waste from Tanks 18F and 19F, was a mechanical crawler called a

Mantis. It was designed to remove sludge solids using a high-pressure hydro-lance to break up waste mounds while an educator aspirated the mobilized waste from the floor.

It would not be practical to deploy the Mantis technology in either FDB-5 or FDB-6. The Mantis' 8-foot length and approximate 3-foot width would make maneuvering inside a DB very difficult and the Mantis probably would not be able to maneuver over discarded jumpers or around the jumper support pedestals to reach all areas of the floor. Additionally, the Mantis would not be able to clean either the in-place or abandoned jumper interiors.

Deployment of vacuum technology in FDB-5 and FDB-6 would require development of a smaller robotic platform with vacuum capability that could maneuver within a congested diversion box. Given that easy entry into the DBs is limited to the existing 5-inch or 6-inch I.D. access ports, deployment of this technology would likely require removal of the cell covers and/or core drilling of larger access ports.

The effectiveness of a vacuum technology on removing any potential waste residue on the DB interior surfaces is uncertain. A vacuum technology would not be effective at removing any residue potentially remaining inside the installed or abandoned jumpers.

6.1.4 Technology Deployment Issues in FDB-5 and FDB-6

Deployment of any mechanical, chemical, or vacuum cleaning technology to perform additional waste removal within FDB-5 or FDB-6 would have costs associated not only with development, testing, and deployment of the technology, but also the costs associated with erection of a containment structure and installation of portable ventilation to control the spread of contamination. Work packages and procedures to support deployment would have to be developed. Deployment of any technology would also need to be evaluated against the existing Documented Safety Analysis to ensure safety of the workers and the public.

In addition, the activities involved with removing cell covers or coring larger access ports, cleaning the interior vault surfaces and removing jumpers for interior cleaning, as well as any chemical addition (e.g., OA) to the vault or potential use of high pressure sprays, would come with the additional risk of potentially contaminating the work area and require additional financial costs and worker exposure for clean-up.

6.2 Estimated Dose Reduction

The FDB-5 and FDB-6 SA results using the assigned inventories were compared to the results in the FTF PA to confirm that this updated information did not adversely impact the FTF PA results. The FDB-5 and FDB-6 SA provides reasonable assurance that, without any additional waste removal in FDB-5 or FDB-6, the groundwater contaminant concentrations derived from the assumed residual contamination in these ancillary structures following removal from service will be below the performance objectives.

Based on the SA, the maximum estimated dose to a future hypothetical MOP resulting from any potential waste residue within FDB-5 is 0.006 mrem/yr and from FDB-6 is 0.01 mrem/year. [SRR-CWDA-2020-00055] Therefore, even if any additional cleaning technology was capable of removing all the residual waste that may remain within the DBs, the maximum potential dose reduction to a hypothetical future MOP would only be 0.01 mrem/yr.

6.3 Assessment Conclusion

The cleaning technologies currently available are not feasible for deployment in FDB-5 and FDB-6.

Nevertheless, even if a technology could be identified and deployed, the essentially zero benefit associated with further residual material removal from FDB-5 and FDB-6 would not justify the associated additional costs, would likely increase worker dose, and risk the potential spread of contamination. Therefore, it may be concluded that further residual removal is not technically practicable from an engineering perspective.

7.0 ANCILLARY STRUCTURE ISOLATION PROCESS AND STABILIZATION STRATEGY

This section summarizes the planned FDB-5 and FDB-6 isolation process and subsequent stabilization strategy to be implemented. Additional isolation details are presented in the *F-Tank Farm Diversion Box 5&6 Isolation Strategy* (SRR-LWE-2020-00045). Additional stabilization details are presented in the *F-Tank Farm Diversion Box 5&6 Grout Strategy* (SRR-LWE-2020-00005).

7.1 FDB-5 and FDB-6 Isolation Process

The isolation process will disconnect FDB-5 and FDB-6 from the FTF Waste Transfer System (WTS) and the FTF support systems. The strategy for isolating both diversion boxes is to ensure there is no ability to add material (waste, water, steam, air, etc.) or energy to the diversion boxes via the site infrastructure.

Isolation is complete when all process lines relevant to FDB-5 and FDB-6 are isolated either via physical obstruction (blank, blind flange, cap, closed valve, etc.), air gap, and/or facility approved Manual 2S administrative controls in addition to Manual E7 compliant designs. [2S Manual, E7 Manual] All electrical sources will be isolated (i.e., physically separated) from equipment and instrumentation. As a result of isolation, there will be no ability to add material (waste, water, steam, air, etc.) or energy to the diversion boxes via the site infrastructure.

Mechanical and electrical isolation matrices will be developed (and maintained in SRS Document Control), that identify the technical baseline drawings and means of isolation. These matrices will serve as the configuration management documents for system isolation points. System isolation points are identified, including the code compliant supply system isolation point, on Piping and Instrumentation Diagrams (P&ID) and Electrical Wiring Diagrams/Schematic drawings as deemed appropriate. Details of the isolation strategy for FDB-5 and FDB-6 are included in Attachment A of the isolation strategy. [SRR-LWE-2020-00045]

As part of the closure of FDB-5 and FDB-6, the above grade portion of the diversion boxes will be entombed in concrete after the interiors are filled with grout. If additional isolation points are identified during the design development for final structure entombment, they will be added to the appropriate mechanical and electrical isolation matrices.

The current strategy is to fully isolate FDB-5 and FDB-6 prior to grout introduction to ensure there is no ability to add material (waste, water, steam, air, etc.) or energy to the diversion boxes via the site infrastructure.

The grout strategy is summarized in Section 7.3.

7.1.1 FDB-5 System Isolation

FDB-5 is connected to six transfer lines which are associated with Nozzles 1, 2, 3, 4, 9, and 10. In addition, there are four other nozzles (Nozzles 5, 6, 7, and 8) with lines that are capped just outside of the diversion box (Figure 7.1-1).

FDB-5 received concentrated supernate from the 242-3F CTS pump tank and then diverted it to either the Tanks 33F and 34F CTS loop line using Nozzles 3 and 4, or the Tanks 25F-28F CTS loop line using Nozzles 9 and 10, then returned any remaining concentrated supernate

back to the CTS pump tank. Since the 242-1F Evaporator has not been operated since 1988, these transfer lines are considered inactive and have been downgraded to Production Support (PS) status. Nozzles 3 through 8 are blanked with dummy Hanford connectors inside the diversion box and do not require modification for isolation.

Figure 7.1-1: FDB-5 Transfer Lines

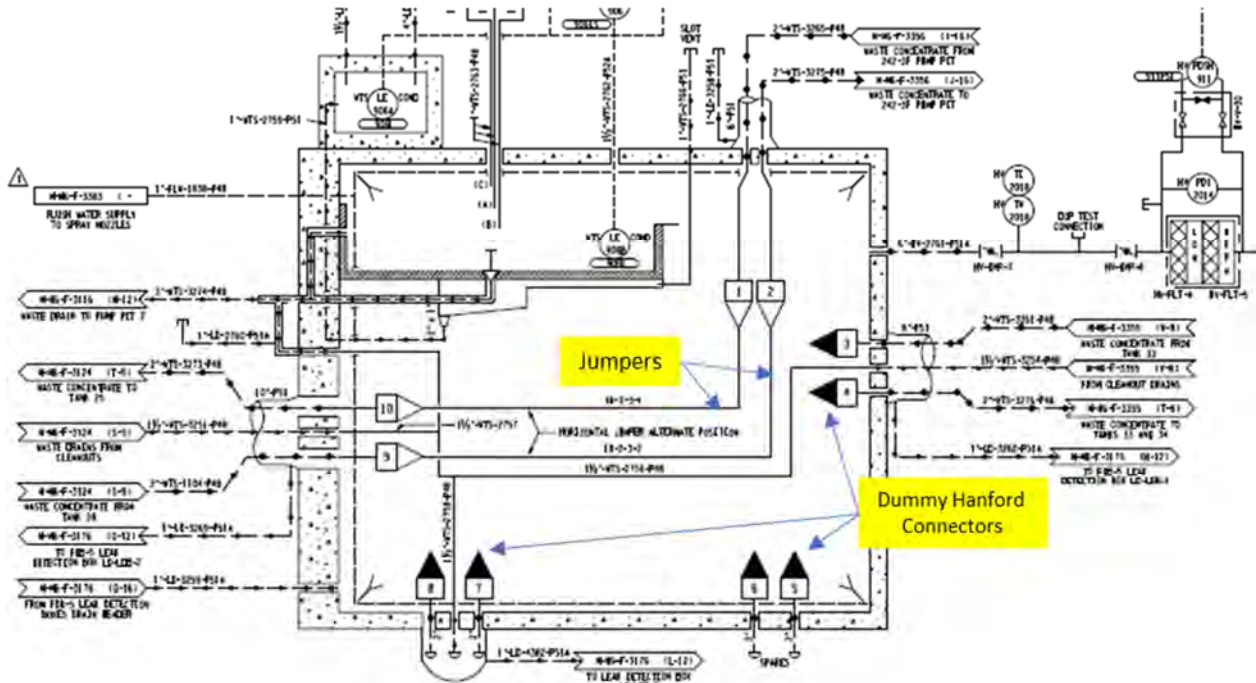

[M-M6-F-3123]

Two jumpers remain connected inside the diversion box. One jumper connects Nozzles 1 and 10, and the other connects Nozzles 2 and 9. The transfer lines connected to Nozzles 1 and 2 are both isolated with dummy Hanford connectors at the 242-3F pump pit and no further action is necessary.

The transfer lines connected to Nozzles 9 and 10 form the Tank 25F-28F CTS loop line which is a transfer path from FDB-5 Nozzle 10 to Tank 25F. The loop continues from Tank 25F to Tank 26F, then from Tank 26F to Tank 27F, then from Tank 27F to Tank 28F, and then returns to FDB-5 Nozzle 9 to complete the loop. The transfer line segments are interconnected with piping between nozzles located within the Riser C2 box at each of the tanks. In Tanks 25F, 27F, and 28F, the piping has a drop valve installed which allowed the concentrated supernate to be released into the tank. In Tank 26F, the piping does not have a drop valve. There is no installed equipment associated with the loop line that has the motive force to transfer waste material into either of the connected FDB-5 jumpers. In addition, facility Technical Safety Requirements (TSRs) prohibit the addition of waste into, or through, FDB-5. [S-TSR-G-00001] No further action is necessary to isolate the transfer lines associated with Nozzles 9 and 10.

FDB-5 has a sump floor drain with a line that leads to F-Pump Pit 2 (FPP-2) and subsequently to F-Pump Tank 2 (FPT-2) (Figure 7.1-2). The sump has an overflow drain line that connects

outside of FDB-5 to the drain line to FPT-2. Enough low-slump concrete will be placed into the diversion box and allowed to set, so that the height of the concrete in the sump is above the overflow drain line in the wall. This will prevent grout with higher flowability from entering the drain line and reaching FPT-2.

Figure 7.1-2: FDB-5 Sump and Overflow Drain Lines

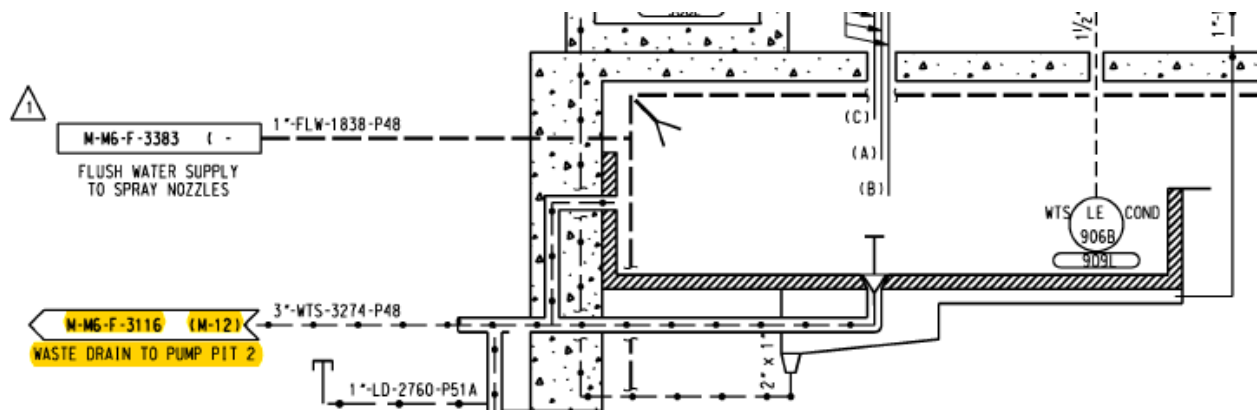

[M-M6-F-3123]

There are three leak detection boxes associated with FDB-5 (LD-LDB-1, LD-LDB-2, LD-LDB-3) that connect to a common 1-inch diameter pipe which penetrates the wall of FDB-5 and is open to the interior of the diversion box. The LDB system was designed to collect any material that might leak into the transfer line jackets for FDB-5. Any material collected in these LDBs would drain into the FDB-5 vault and flow to the sump. Because there is no equipment associated with the transfer lines that has the motive force to transfer waste material into the transfer lines, there is little chance for leakage into the transfer line jackets and into the LDB system. No further action is necessary to isolate the LDB network for FDB-5. Details of the LDB system are presented in the isolation plan. [SRR-LWE-2020-00045]

When FDB-5 is stabilized, grout will flow, to some extent, into the drain line coming from the LDBs effectively sealing off that pathway for any material to enter FDB-5.

7.1.2 FDB-6 System Isolation

FDB-6 is connected to six transfer lines associated with Nozzles 1 through 6. Two additional nozzles, Nozzles 7 and 8, are capped just outside of the diversion box (Figure 7.1-3). FDB-6 was used to direct supernate to the 242-1F Evaporator System for volume reduction from either Tank 7F using Nozzle 1, or Tank 26F using Nozzle 4. Because the 242-1F Evaporator has not been operated since 1988, these transfer lines are considered inactive and have been downgraded to PS status. Nozzles 1, 2, 7, and 8 are blanked with dummy Hanford connectors inside the diversion box and do not require modification for isolation.

Two jumpers remain connected inside the diversion box. One jumper connects Nozzles 3 and 5, and the other connects Nozzles 4 and 6. The transfer lines connected to Nozzles 5 and 6 are both isolated at the 242-1F Evaporator with installed blanks, and no further action is necessary to isolate them. The transfer line connected to Nozzle 3 was used as a vent line for the 242-1F Evaporator and is currently connected to FPT-3 Nozzle 11. FPT-3 Nozzle 11 is open to the

headspace in FPT-3 and there is no installed equipment associated with the nozzle that has the motive force to transfer waste material into this jumper. In addition, facility TSRs prohibit the addition of waste into or through FDB-6. Therefore, no further action is necessary to isolate the transfer line associated with FDB-6 Nozzle 3.

Figure 7.1-3: FDB-6 Transfer Lines

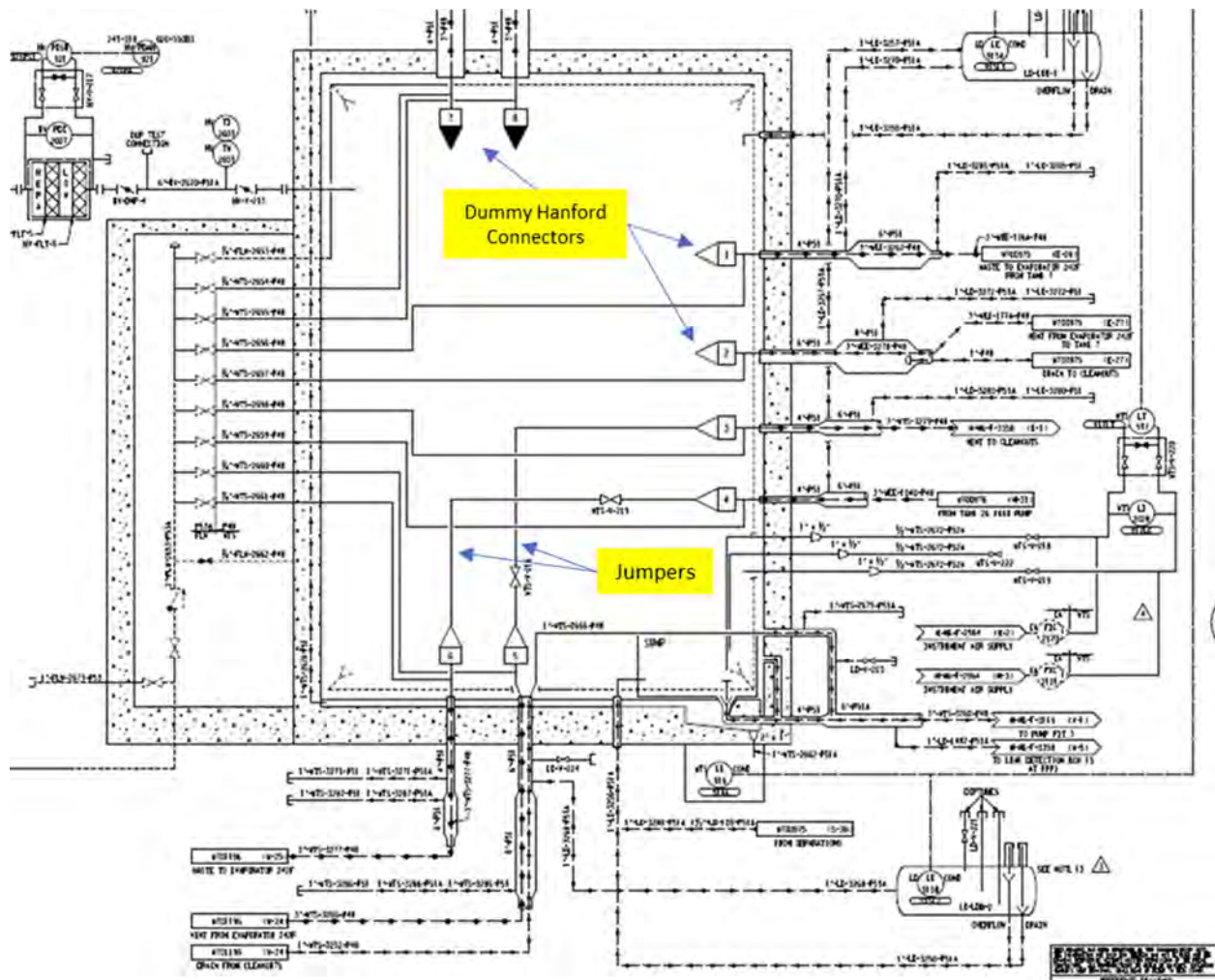

[M-M6-F-3357]

The transfer line connected to Nozzle 4 was used to transfer waste from Tank 26F to the 242-1F Evaporator and is currently connected to a transfer pump in Tank 26F Riser 1. The transfer pump has since been removed from the riser, therefore no motive force exists to transfer waste material into the FDB-6 jumper. In addition, facility TSRs prohibit the addition of waste into or through FDB-6. No further action is necessary to isolate the transfer line associated with Nozzle 4.

FDB-6 has a sump drain line that leads to FPP-3 (Figure 7.1-4). The sump has an overflow drain line that connects outside of FDB-6 to the drain line to FPP-3. Enough low-slump concrete will be placed into the diversion box and allowed to set, so that the height of the concrete in the sump is above the overflow drain line in the wall. This will prevent grout with higher flowability from entering the drain line and reaching FPP-3.

Figure 7.1-4: FDB-6 Sump and Overflow Drain Lines

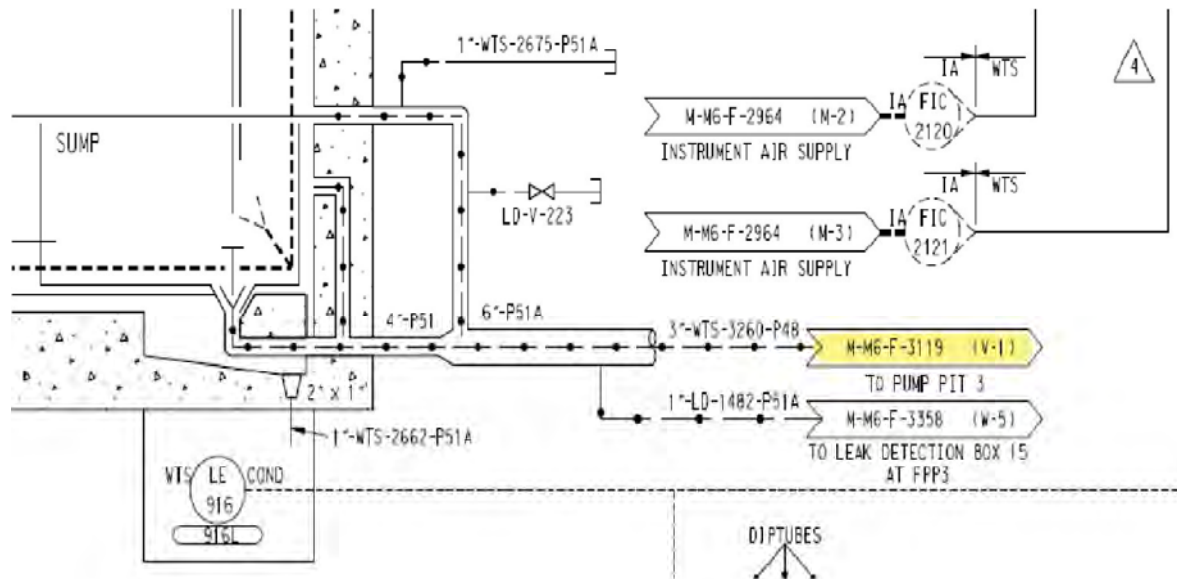

[M-M6-F-3357]

There are two LDBs associated with FDB-6 (LD-LDB-1, LD-LDB-2) that each have a 1-inch diameter pipe which penetrates the wall of FDB-6 and is open to the interior of the diversion box. Any material collected in these LDBs would drain into FDB-6 and flow to the sump. Because there is no equipment associated with the transfer lines that has the motive force to transfer waste material into the transfer lines, there is little chance for leakage into the transfer line jackets and into the LDB system. No further action is necessary to isolate the LDB network for FDB-6. Details of the LDB system are presented in the isolation plan. [SRR-LWE-2020-00045]

When FDB-6 is stabilized, grout will flow, to some extent, into the drain line coming from the LDBs effectively sealing off that pathway for any material to enter FDB-6.

7.2 Additional Diversion Box Systems Requiring Isolation

Flush Water Systems

FDB-5 has two flush water supply lines. To isolate one supply line, valve FLW-V-113 will be locked out to prevent flow into the diversion box.

The second FDB-5 flush water supply line has already been isolated. This same isolation point also isolates the one, and only flush water supply line into FDB-6.

Heating and Ventilation (H&V) Systems

FDB-5 has one ventilation line that is vented out to a HEPA filter and fan. The line will be closed at an in-line valve. This will isolate the temperature indicators, the radiation monitoring system, HEPA filter and fan that are connected down the line behind the valve.

FDB-6 has one ventilation line that is vented out to a HEPA filter and fan. The line will be closed at an in-line valve. This will isolate the temperature indicators, the radiation monitoring system, and HEPA filter, and the fan that are connected down the line behind the valve.

Dip Tubes

FDB-5 has three dip tubes that reach into the sump. They will be isolated by closing a valve at the surface.

FDB-6 has three dip tubes that reach into the sump. They will be isolated by closing a valve at the surface.

Conductivity Probes

The FDB-5 leak detection sump conductivity probe and sump conductivity probe will be electrically isolated to ensure there is no energized circuit inside FDB-5.

The FDB-6 leak detection sump conductivity probe will be electrically isolated to ensure there is no energized circuit inside FDB-6. The sump conductivity probe has been previously isolated.

Additional details of the isolation strategy planned for each diversion box are presented in Attachment A of the *F-Tank Farm Diversion Box 5&6 Isolation Strategy* (SRR-LWE-2020-00045).

7.3 FDB-5 and FDB-6 Stabilization Strategy

7.3.1 Grout Option Selection

In May 2002, DOE issued an Environmental Impact Statement (EIS) on waste tank cleaning and stabilization alternatives. [DOE/EIS-0303] The EIS concluded the Fill-with-Grout alternative was preferred. The DOE also issued a Record of Decision (ROD) selecting the Fill-with-Grout alternative for SRS waste tank closure. [DOE/EIS-0303 ROD] As explained in the *Regulatory Strategy for Closure of F-Area and H-Area Tank Farms Ancillary Structures* (SRR-CWDA-2018-00064), meeting the requirements regarding isolation and stabilization contained in the CGCP for ancillary structures will satisfy the criteria of the 2002 EIS and associated ROD.

Evaluations described in the EIS showed the Fill-with-Grout alternative was the best approach to minimize human health and safety risks associated with closure of the waste tanks and ancillary structures. [DOE/EIS-0303]

Because FDB-5 and FDB-6 do not contain an appreciable amount of waste, using grout with reducing properties to chemically treat infiltrating water is not necessary. The primary purpose of the grout required for the operational closure of FDB-5 and FDB-6 is structure stabilization to prevent future subsidence of the FTF closure cap. In the case of FDB-5 and FDB-6, the 3-foot thick, rebar reinforced concrete cell covers serve as an adequate intruder barrier; therefore, grout with a compressive strength greater than 2,000 psi is not required.

7.3.2 Grout Functions, Requirements, and Formulation

The grout proposed for filling FDB-5 and FDB-6 is a zero-bleed variant of Controlled Low-Strength Material (CLSM). CLSM has been widely used in applications across SRS for

various fill applications and its properties are well understood and documented. CLSM was one of three grout formulations used in the stabilization of Tanks 17F and 20F when these tanks were operationally closed in the late 1990s.

The advantages of using CLSM for stabilizing FDB-5 and FDB-6 are ease of use and low bleedwater. CLSM is highly flowable prior to gelling which allows it to flow and completely fill the enclosing space with little chance of leaving voids. CLSM is self-consolidating and self-leveling and does not require mechanical assistance to become level. The zero-bleed CLSM has admixtures to reduce bleedwater which limits the amount of liquid accumulating on the grout surface during placement. However, the low viscosity of CLSM requires sealing any openings to locations where it is not desired.

As described below, a low-slump concrete will be used to fill and seal the DB sumps and sump overflow drain lines prior to filling the vaults with CLSM. Because a mound is desired to reach and effectively seal the drain and sump overflow line openings, no mechanical vibration will be used unless it becomes necessary for desired concrete placement.

SCDHEC approval for CLSM and low-slump concrete use was necessary because they are not currently listed in the CGCP as approved grout formulations for waste tank or ancillary structure stabilization. CLSM and low-slump concrete use was approved by SCDHEC on February 25, 2021. [SRR-OS-2021-00046]

The supplier selected to provide grout for the diversion box fillings will be required to demonstrate the ability to batch and deliver the flowable, structural fill material to FTF. Samples of material batched at full-scale will be tested to qualify the ability of the grout subcontractor to produce and deliver the mix.

7.4 Diversion Box Grouting Plan

Grout will be supplied by an off-site vendor. The vendor will deliver the grout using unmodified concrete mixer trucks to a grout distribution and placement station in FTF that will be installed and operated by SRR.

The first cement mixer truck will be tested prior to use to ensure the correct mix is being used to grout the diversion boxes. A chute will be used to deliver the grout to the diversion box interior through one of the access ports. The chute will ensure the truck's hopper will not be contaminated and also provided some adjustability for grout pouring and placement.

A portable ventilation system and in-stream radiation monitoring will be used during the grouting to ensure any contamination within the diversion box does not escape into the surroundings.

7.4.1 FDB-5 Grouting

FDB-5 will be filled using the existing access ports and the 6-inch core hole drilled through the cell cover in 2020. If necessary, a layer of absorbent material (AquaSorbe-HP) will first be placed into the sump to congeal (gel) any free liquid. Enough low-slump concrete will then be placed inside the vault to block the sump drain and sump overflow line to ensure that no CLSM can flow out and reach FPP-2. The low-slump concrete will be allowed to sufficiently set before the rest of the diversion box is filled with the zero-bleed CLSM.

The CLSM will be poured into the diversion box via one of the access ports in the cell covers. A video camera will be placed inside the diversion box through another cell cover access port.

The ventilation will be installed at the same access port as the camera, or if determined to be necessary, a new access port will be core drilled in the cell covers. While the grout is being poured, SRR Engineering will visually monitor the grout configuration inside the diversion box for void space formation and to confirm the CLSM is self-leveling in a satisfactory manner. If unsatisfactory mounding or other irregularities are seen, SRR Engineering will evaluate the conditions to determine alternate pour methods to minimize void spaces.

The camera will remain inside the diversion box interior until it needs to be removed to prevent being entombed within the grout. When it is removed from the vault interior, it will then be positioned to view down the access port to monitor the grout level as it rises into the access port.

As the grout level rises, CLSM will flow into, and seal the open piping penetrations. Prior line isolation will prevent CLSM flowing into undesired locations. The grout will also flow into the abandoned jumpers on the vault floor and fill them to the extent possible. The grout will also encase any other equipment remaining in the vault including the installed jumpers.

The flush water valve box will partially fill as the grout level rises above the piping slot into the vault. After the vault is filled and the grout has set, the valve box risers will be opened and the remainder of the valve box filled with CLSM. The valve box risers will be re-inserted and the valve box sealed.

The rain cover will be cut into pieces and placed into a container for disposal. The portable ventilation system used during grouting will also be removed and properly dispositioned.

Once the internal diversion box grouting process is complete and cured, formwork and rebar for a monolithic pour will be erected around the footprint of the diversion box, including the valve box and the pads containing the sump leak detection box risers, the diversion box sump risers, and the diptubes. A high-strength concrete will then be poured inside the formwork to fully entomb the diversion box.

It will not be necessary to fill the LDB because it is outside the footprint of the vault and does not represent a future fast-flow path for infiltrating groundwater. It will also be effectively isolated as a result of the sump filling, and subsequent entombment of the diversion box.

If the ventilation duct for FDB-5 is not filled with grout to grade level during the diversion box filling, any portion of the duct remaining above grade will also need to be entombed within the high-strength concrete monolith.

7.4.2 FDB-6 Grouting

FDB-6 shall be filled using the four existing ports in the diversion box cell covers. The grout filling process will be the same as described for the FDB-5 grouting above.

7.4.3 Equipment Abandoned in the Diversion Boxes

Both diversion boxes have internal equipment that will be abandoned, including thermocouples, jumpers, dummy nozzles, and plastic pieces. As discussed above, the abandoned equipment will be entombed in-place and internal void spaces filled to the extent practicable as the grout level rises.

Typically, the goal of equipment fill grouting is to eliminate, to the extent practicable, possible vertical fast flow paths through the grout that could allow infiltrating water to reach the residual

waste on the floor sooner and/or without being conditioned by the reducing properties of the grout. In the case of FDB-5 and FDB-6, there is no vertical equipment with internal void space running from the top to the bottom of the diversion boxes. There is also little, to no waste on the floor of the two diversion boxes, so potential fast flow paths to the residual waste are not of concern.

As mentioned, the consistency of the CLSM will allow it to flow into the abandoned jumpers on the diversion box floors as much as allowable before curing occurs. The two jumpers in FDB-5 and the two in FDB-6 which are currently connected to wall nozzles will remain in their current configuration. [SRR-LWE-2020-00045]

7.4.4 Transfer Line Grouting

As described in the isolation strategy, the two jumpers in FDB-5 and the two in FDB-6 which are still connected to nozzles will remain in their current configuration. The jumpers are considered part of the FTF transfer line system and, as discussed in the CGCP, there are no plans to add fill material to the FTF transfer lines.

8.0 MAINTENANCE AND MONITORING PLANS

The FFA establishes requirements for the prevention and mitigation of releases or threats of releases at, or from, the FTF and any needed soil and groundwater remediation when all FTF waste tanks and ancillary structures have been removed from service. Because not all waste tank systems will be removed from service at the same time, there will be an interim period where some systems remain operational, while others are removed from service. [WSRC-OS-94-42]

Following stabilization, FDB-5 and FDB-6 will become subject to the maintenance and monitoring requirements of an IROD/RCRA Permit Modification. These ancillary structures will then be removed from Construction Permit #17,424-IW. In the interim period following RFS until application of the IROD/RCRA Permit Modification and any subsequent needed final FFA corrective/remedial actions, FDB-5 and FDB-6 will be subject to the following maintenance and monitoring requirements:

- Historically, groundwater monitoring has been performed in accordance with the current SRS programs that have been conducted inside and around FTF since the 1970's, as requested by SCDHEC in support of Construction Permit #17,424-IW (DHEC_01-25-1993). The *F-Area Tank Farm Groundwater Monitoring Plan* (SRNS-RP-2011-00995) provides the requirements for groundwater monitoring. The groundwater sample analyses are performed by a laboratory certified for applicable parameters in accordance with SCDHEC Regulation 61-81, *State Environmental Laboratory Certification Program*. Results have been and will continue to be reported annually to SCDHEC and EPA.
- Annual visual inspections of the area surrounding FDB-5 and FDB-6 will be conducted and maintenance actions will be performed as appropriate. Where visible, the grout and entombing concrete will be inspected for significant cracking. The area stormwater system will be maintained to ensure that any possible water infiltration through the grout and concrete is minimized. Inspections will commence within one year of grout stabilization, because the final concrete entombment may be later, and will be performed annually. Deficiencies will be corrected as soon as practical and will be documented by procedure. Within 30 days of detection, DOE will notify SCDHEC of any significant cracking of the grout or concrete or degradation of the stormwater system and will establish a schedule to complete necessary maintenance activities. Inspection records will be maintained until all tanks and ancillary structures have been removed from service and the FTF OU is closed.
- Access controls for on-site workers will be provided via the Site Use Program, Site Clearance Program, work control, worker training, worker briefing on health and safety requirements, and identification signs located at the waste unit boundaries.
- EPA and SCDHEC will be notified in advance of changes in land use in accordance with the *Savannah River Site Land Use Plan* (SRNS-RP-2013-00162).
- Access controls against trespassers will be provided as consistent with the 2000 RCRA Part B Permit Renewal Application, Volume I, Section F.1, which describes the security procedures and equipment, 24-hour surveillance system, artificial or natural barriers, entry control systems, and warning signs in place at the SRS boundary. [WSRC-IM-98-30]

9.0 CONCLUSIONS

As determined by the individual camera inspections, except for the estimated 0.3-gallon salt deposit in FDB-6, there are no obvious solids accumulations in either FDB-5 or FDB-6.

Based on the information presented in this CM, DOE has determined that further waste removal efforts are not technically practicable from an engineering perspective for FDB-5 and FDB-6. This determination is based on the approach followed and defined in the CGCP.

- Visual Observations Inside the FDB-5 Vault – The determination that no residual materials are present was based on visual observations using remotely operated cameras inserted through the inspection port and a hole cored through a vault cell cover. Figure 9.0-1 shows various views of the FDB-5 interior. Radiation monitoring and smear sampling results during the inspections did not indicate the presence of obvious residual material inside the vault but were indicative of surface contamination.

Figure 9.0-1: Views of the FDB-5 Vault Interior



- Visual Observations Inside the FDB-6 Vault – Visual inspections determined that with the exception of an estimated 0.3 gallons of residual material in one area of the vault floor, FDB-6 is free of any accumulated solids. The material is thought to be crystallized supernate. [U-ESR-F-00092] The visual inspections inside the vault were performed using remotely operated cameras inserted through the inspection ports in the vault cell covers. Figure 9.0-2 shows various views of the FDB-6 interior. Radiation monitoring during the inspections did not indicate the presence of a significant amount of residual material inside the vault.

Figure 9.0-2: Views of the FDB-6 Vault Interior



- Analysis of Deploying an Additional Waste Removal Technology – An analysis of deploying another cleaning technology concluded that it was not technically practicable from an engineering perspective to perform additional waste removal activities. The analysis included such factors as technology capabilities and effectiveness (Section 6.0). The evaluation concluded that:
 - No existing technology has been identified that is suitable for deployment to effectively remove additional residual material that might be present on the FDB-5 and FDB-6 vault floor and jumper interior surfaces.

- The very small benefit that would be realized by further residual material removal from FDB-5 and FDB-6 does not justify the anticipated costs associated with developing and deploying a new technology.
- The worker dose for performing additional waste removal does not justify the minimal future risk reduction potentially realized.
- Human Health and Environment Impacts – As allowed by the CGCP and LWTRSAPP for low-volume conditions; radiological and chemical inventories were assigned to FDB-5 and FDB-6. Based on the FDB-5 and FDB-6 SA groundwater modeling results using the assigned inventories (Section 5.0), there is reasonable assurance that groundwater concentrations derived from residual contamination in the FTF waste tanks and ancillary structures will meet the performance objectives. These modeling results provide assurance that human health and the environment will continue to be protected after the FTF waste tank systems have been stabilized with grout and removed from service. [SRR-CWDA-2020-00055]
- Isolation Strategy – The isolation strategy ensures that FDB-5 and FDB-6 will be isolated from the remainder of the FTF WTS and the FTF support systems, preventing their use for any future waste processing activities (Section 7.1).
- Stabilization – DOE evaluated stabilization alternatives in the EIS (DOE/EIS-0303) and determined that the “Fill with Grout” alternative is the best approach to minimize human health and safety risks associated with the RFS of waste tanks and ancillary structures (Section 7.3).
- Maintenance and Monitoring – DOE will monitor groundwater, conduct annual surface visual inspections, and control access to the FTF during the interim period between the FDB-5 and FDB-6 RFS until final closure of the FTF OU (Section 8.0).

DOE has determined that after completion of this CM, all CGCP requirements will have been met to proceed with the FDB-5 and FDB-6 RFS and DOE will be ready to stabilize these ancillary structures with grout. Approval of this CM by SCDHEC signifies State acceptance of the proposed DOE closure activities for FDB-5 and FDB-6 and State concurrence that waste removal activities for FDB-5 and FDB-6 can cease. In accordance with the FFA, EPA will also provide concurrence that waste removal activities may cease. Following stabilization, DOE will submit separate Final Configuration Reports (FCRs) for FDB-5 and FDB-6 to SCDHEC with certification that the RFS activities have been performed in accordance with the CGCP and this CM.

DOE has determined that any remaining residual material in FDB-5 and FDB-6 has been removed to the extent technically practicable from an engineering perspective and DOE is ready to proceed to isolation and stabilization activities summarized in Section 7.0.

Based on the information provided in this CM and supporting documents, it may be concluded that:

- 1) There is reasonable assurance that, at the time of final FFA corrective/remedial actions, groundwater concentrations derived from residual contamination in the waste tanks and ancillary structures will be less than the South Carolina state drinking water standards and,
- 2) Further residual removal is not technically practicable from an engineering perspective.

10.0 REFERENCES

2S Manual, *Conduct of Operations Manual*, Savannah River Site, Aiken, SC, Rev.1, February 14, 2013 (Table of Contents)

10 CFR 61.41, *Licensing Requirements for Land Disposal of Radioactive Waste*, U.S. Nuclear Regulatory Commission, Washington, D.C., July 27, 2020.

10 CFR 61.42, *Protection of Individuals from Inadvertent Intrusion*, U.S. Nuclear Regulatory Commission, Washington, D.C., July 27, 2020.

138-8-F-522, *Diversion Box FDB-6*, Manual SW1.10, Savannah River Site, Aiken, SC, Rev. 7, February 28, 1992. (Cancelled)

B-UG-H-00058, *Waste Characterization System Online Software User Guide*, Savannah River Site, Aiken, SC, Rev. 4, July 5, 2018.

CBU-PIT-2005-00120, *Ancillary Equipment Residual Radioactivity Estimate To Support Tank Closure Activities For F-Tank Farm*, Westinghouse Savannah River Company, Savannah River Site, Aiken, SC, Rev. 0, June 16, 2005.

DHEC_01-25-1993, Sadler, M.F., *Construction Permit #17,424-IW, SRS F/H-Area, Aiken and Barnwell County*, South Carolina Department of Health and Environmental Control, Columbia, SC, January 25, 1993.

DOE/EIS-0303, *Savannah River Site High-Level Waste Tank Closure Final Environmental Impact Statement*, U.S. Department of Energy – Savannah River, Savannah River Site, Aiken, SC, May 2002.

DOE/EIS-0303 ROD, *Savannah River Site High Level Tank Closure Final Environmental Impact Statement Record of Decision*, U.S. Department of Energy, Washington DC, August 19, 2002.

DOE M 435.1-1 Change 2, *Radioactive Waste Management Manual*, U.S Department of Energy, Washington, DC, June 2011.

DPSP 79-21-3, *Waste Management Programs Report for March 1979*, E.I. DuPont De Nemours & Company, Atomic Energy Division Savannah River Plant, Aiken, SC, March 1979.

DPSP 79-21-12, *Waste Management Programs Report for December 1979*, E.I. DuPont De Nemours & Company, Atomic Energy Division Savannah River Plant, Aiken, SC, December 1979.

DPSP 81-21-10, *Waste Management Programs Report for October 1981*, E.I. DuPont De Nemours & Company, Atomic Energy Division Savannah River Plant, Aiken, SC, October 1981.

E7 Manual, *Conduct of Engineering*, Savannah River Site, Aiken, SC, (Table of Contents).

M-M6-F-3123, *F Area New Hill Diversion Box 5 Heating and Ventilation Waste Transfer System Piping and Instrumentation Drawing*, Savannah River Site, Aiken, SC, Rev. 4, June 2012.

M-M6-F-3357, *F Area Old Hill Diversion Box 6 Waste Transfer System Piping and Instrument Drawing*, Savannah River Site, Aiken, SC, Rev. 6, July 24, 2013.

NDAA Section 3116, *Section 3116 of the Ronald W. Reagan National Defense Authorization Act for Fiscal Year 2005 (NDAA)*, Defense Site Acceleration Completion, October 2004.

S-TSR-G-00001, *Concentration, Storage and Transfer Facilities Technical Safety Requirements*, Savannah River Site, Aiken, SC, Rev. 60, March 2020.

SCDHEC R.61-58, *State Primary Drinking Water Regulation*, <http://www.scdhec.gov/Agency/RegulationsAndUpdates/LawsAndRegulations/Water/>, South Carolina Department of Health and Environmental Control, Columbia, SC, September 2014.

SCDHEC R.61-67, *Standards for Wastewater Facility Construction*, <http://www.scdhec.gov/Agency/RegulationsAndUpdates/LawsAndRegulations/Water/>, South Carolina Department of Health and Environmental Control, Columbia, SC, June 2015.

SCDHEC R.61-82, *Proper Closeout of Wastewater Treatment Facilities*, <http://www.scdhec.gov/Agency/RegulationsAndUpdates/LawsAndRegulations/Water/>, South Carolina Department of Health and Environmental Control, Columbia, SC, April 11, 1980.

SRNS-RP-2011-00995, *F-Area Tank Farm Groundwater Monitoring Plan*, Savannah River Site, Aiken, SC, Rev. 1, February 2012.

SRNS-RP-2013-00162, *Savannah River Site Land Use Plan*, Savannah River Site, Aiken, SC, May 2013.

SRR-CWDA-2009-00045, *F-Tank Farm Waste Tank Closure Inventory for Use in Performance Assessment Modeling*, Savannah River Site, Aiken, SC, Rev. 2, October 2012.

SRR-CWDA-2010-00124, *Tank 18/Tank 19 Special Analysis for the Performance Assessment for the F-Area Tank Farm at the Savannah River Site*, Savannah River Site, Aiken, SC, Rev. 0, February 2012.

SRR-CWDA-2011-00050, *Liquid Waste Tank Residuals Sampling and Analysis Program Plan*, Savannah River Site, Aiken, SC, Rev. 4, June 2017.

SRR-CWDA-2012-00106, *Tanks 5 and 6 Special Analysis for the Performance Assessment for the F-Tank Farm at the Savannah River Site*, Savannah River Site, Aiken SC, Rev. 1, January 2013.

SRR-CWDA-2017-00015, *Consolidated General Closure Plan for F-Area and H-Area Waste Tank Systems*, Savannah River Site, Aiken, SC, Rev. 1, April 2017.

SRR-CWDA-2018-00059, *Email (August 23, 2018) Between Malcolm Smith and Keith Harp of FDB-5/6 Operational Events Interview Summary*, Savannah River Site, Aiken, SC, August 23, 2018.

SRR-CWDA-2018-00064, *Regulatory Strategy for Closure of F-Area and H-Area Tank Farms Ancillary Structures*, Savannah River Site, Aiken, SC, Rev. 1, December 2018.

SRR-CWDA-2020-00024, *F-Area Diversion Box 5 Sample Location Determination Report*, Savannah River Site, Aiken, SC, Rev. 0, December 2020.

SRR-CWDA-2020-00029, *Inventory Assignment at Closure for FDB-5 and FDB-6*, Savannah River Site, Aiken, SC, Rev. 1, February 23, 2021.

SRR-CWDA-2020-00033, *F-Area Diversion Box 6 Sample Location Determination Report*, Savannah River Site, Aiken, SC, Rev. 0, December 2020.

SRR-CWDA-2020-00055, *FDB-5 and FDB-6 Special Analysis for the Performance Assessment for the F-Tank Farm at the Savannah River Site*, Savannah River Site, Aiken, SC, Rev. 1, February 2021.

SRR-CWDA-2020-00059, *Proposal to Cease Waste Removal Activities in F-Area Diversion Boxes 5 and 6*, Savannah River Site, Aiken, SC, Rev. 0, July 13, 2020.

SRR-LWE-2010-00240, *Tank Mapping Methodology*, Savannah River Site, Aiken, SC, Rev. 1, November 28, 2012.

SRR-LWE-2020-00005, *F-Tank Farm Diversion Box 5&6 Grout Strategy*, Savannah River Site, Aiken, SC, Rev. 0, August 2020.

SRR-LWE-2020-00045, *F-Tank Farm Diversion Box 5&6 Isolation Strategy*, Savannah River Site, Aiken, SC, Rev. 0, August 2020.

SRR-LWE-2020-00095, *Annual SCDHEC Technology Briefing*, Savannah River Site, Aiken, SC, Rev. 0, November 18, 2020.

SRR-OS-2020-00309, *Request for Concurrence to Proceed to Sample and Analysis Phase of the Closure Process for F-Area Diversion Boxes (FDB) 5 and 6 (SEMS Number 23) dated July 28, 2020 and received electronically July 28, 2020*, South Carolina Department of Health and Environmental Control, Columbia, SC, July 29, 2020.

SRR-OS-2020-00331, *Request for Concurrence to Proceed to Sample and Analysis Phase of the Closure Process for F Area Diversion Boxes (FDB) 5 and 6 (SEMS Number: 23) dated July 28, 2020*, U.S. Environmental Protection Agency, Washington DC, August 11, 2020.

SRR-OS-2021-00046, *Request for Approval to Use Alternate Fill Materials for Operational Closure of Tank Farm Ancillary Structures at Savannah River Site, Aiken, SC, dated February 3, 2021 (SRR-CWDA-2021-0010)*, South Carolina Department of Health and Environmental Control, Columbia, SC, February 25, 2021.

SRS-REG-2007-00002, *Performance Assessment for the F-Tank Farm at the Savannah River Site*, Savannah River Site, Aiken, SC, Rev. 1, March 31, 2010.

TKFM-M-20200205-28, *FDB-5 Smear Survey of Cell Floor*, Savannah River Site, Aiken, SC, Rev. 0, February 5, 2020.

U-ESR-F-00092, *F Area Diversion Box #6 Final Volume Determination and Uncertainty Estimate*, Savannah River Site, Aiken, SC, Rev. 1, February 22, 2021.

U-ESR-F-00094, *F Area Diversion Box #5 Final Volume Determination and Uncertainty Estimate*, Savannah River Site, Aiken, SC, Rev. 1, February 22, 2021.

V-18-0439, *Video inspection for FDB-6 July 13, 2018*, Savannah River Site, Aiken, SC, July 13, 2018, *Maintained in the Structural Authority and Inspection database.*

V-18-0791, *Video for FDB-5 Valve Cup Adjustment and Camera Inspection*, Savannah River Site, Aiken, SC, November 1, 2018, *Maintained in the Structural Authority and Inspection database.*

V-19-1125, *Video for Performed Annual Inspection and Monitoring*, Savannah River Site, Aiken, SC, December 7, 2019, *Maintained in the Structural Authority and Inspection database.*

V-19-0946, Video for *Observe the Conditions Within the Flush Water Box at FDB-6*, Savannah River Site, Aiken, SC, August 31, 2019, *Maintained in the Structural Authority and Inspection database.*

V-20-0140, Video for *FDB-5 Camera Inspection*, Savannah River Site, Aiken, SC, February 5, 2020, *Maintained in the Structural Authority and Inspection database.*

W702275, *Savannah River Plant Bldg 241F Waste Storage FAC FY 76 FDB6 Equi Arrgt Sheet 1 Process and Instruments*, Savannah River Site, Aiken, SC, Rev. 47, August 3, 1979.

W702358, *Savannah River Plant Bldg 241F Waste Storage Fac FY'76 FDB-6 Ppg Arrgt Sht 1 Process*, E.I. DuPont De Nemours & Company, Wilmington, Delaware, Rev. 31, September 1994.

W702452, *Savannah River Plant Bldg 241F Waste Storage Facilities FY'76 FDB5 Equip. Arrgt. Process & Instruments*, E.I. DuPont De Nemours & Company, Wilmington, Delaware, Rev. 57, August 1996.

W703320, *Savannah River Plant Bldg 241F Diversion Box #5 Plans Sections & Details Sheet 2 Concrete & Steel*, E.I. DuPont De Nemours & Company, Wilmington, Delaware, Rev. 82, August 28, 1978.

W703321, *Savannah River Plant Building 241-31F Diversion Box #5 S/S Liner Details Steel*, Savannah River Site, Aiken, SC, Rev. 57, March 1978.

W703384, *Savannah River Plant Building 241-32F Diversion Box #6 Plans, Sections, and Details – Sheet #1*, Savannah River Site, Aiken, SC, Rev. 61, November 29, 1977.

W703386, *Savannah River Plant Building 241-32F Diversion Box #6 Plans, Sections, and Details Sheet #2 Concrete & Steel*, Savannah River Site, Aiken, SC, Rev. 95, September 13, 1994.

WDPD-20-37, *Request for Concurrence to Proceed to Sample and Analysis Phase of the Closure Process for F Area Diversion Boxes (FDB) 5 and 6 (SEMS Number: 23)*, U.S. Department of Energy, Washington, DC, July 29, 2020.

WSRC-IM-98-30, *2000 RCRA Part B Permit Application*, Volume I, Section F.1, Savannah River Site, Aiken, SC, Rev. 1, January 2002.

WSRC-OS-94-42, *Federal Facility Agreement for the Savannah River Site*, Savannah River Site, Aiken, SC, August 9, 2016.

APPENDIX A: FTF WASTE TANK SYSTEMS CLOSURE TRACKING

Future closure of the waste tanks and ancillary structures will be conducted in such a way that structures will be included in CMs when determined that it is practical to remove the structures from service simultaneously with the waste tanks and there is no longer a need for the ancillary structures to manage waste in tanks that are still in service. The ancillary structures to be closed as part of the HTF are listed in Table A-1. As CMs are developed and approved, Table A-1 will be updated to include the document number and date of RFS for each of the ancillary structures listed in Permit #17,424-IW (DHEC_01-25-1993) to ensure that all waste tanks and ancillary structures have been addressed.

Table A-1: FTF Waste Tank Systems Removal from Service Tracking Table

Waste Tank System Listed in SCDHEC Construction Permit #17,424-IW	Closure Module / Addendum Document Number	Removal from Service Date ^a
Tank 1		
Tank 2		
Tank 3		
Tank 4		
Tank 5	SRR-CWDA-2012-00071	December 2013
Tank 6	SRR-CWDA-2012-00071	December 2013
Tank 7		
Tank 8		
Tank 17	PIT-MISC-0004	December 1997
Tank 18	SRR-CWDA-2010-00003	September 2012
Tank 19	SRR-CWDA-2010-00003	September 2012
Tank 20	PIT-MISC-0002	July 1997
Tank 25		
Tank 26		
Tank 27		
Tank 28		
Tank 33		
Tank 34		
Tank 44		
Tank 45		
Tank 46		
Tank 47		
242-F (1F) Evaporator Pot		
Condenser		
Cesium Removal Column Pump Tank		
Overheads Tank South		
Overheads Tank North		
Overheads Diverting Tank		

Table A-1: FTF Waste Tank Systems Removal from Service Tracking Table (continued)

Waste Tank System Listed in SCDHEC Construction Permit #17,424-IW	Closure Module / Addendum Document Number	Removal from Service Date ^a
242-3F Concentrate Transfer System		
242-16F (2F) Evaporator Pot		
Condenser		
Mercury Collection Tank		
Cesium Removal Column Pump Tank		
Overheads Tank #1, South		
Overheads Tank #2, North		
FPP-1 and FPT-1		
FPP-2 and FPT-2		
FPP-3 and FPT-3		
FDB-1		
FDB-2		
FDB-3		
FDB-4		
FDB-5	SRR-CWDA-2020-00011	
FDB-6	SRR-CWDA-2020-00011	
F-Area Catch Tank		
Tanks 17-20 Underliner Sump Drains ^b		

^a As used here, the *Removal From Service Date* is the DOE letter date documenting operational closure to SCDHEC and EPA.

^b Not specifically listed in the Permit, but closure committed to in the *Tanks 18 and 19 Final Configuration Report* (SRR-CWDA-2012-00170).

JMLIGHT
8035575456
SAVANNAH RIVER NUCLEAR SOLUTIO
BLDG 731-1N RM 113
AIKEN SC 29808

1.1 LBS LTR

1 OF 1

SHIP TO:

MS. MELISSA JOHNSON
7067371744
AUGUSTA UNIVERSITY
REESES LIBRARY GOVT. SECTION
2500 WALTON WAY
AUGUSTA GA 30904-4562

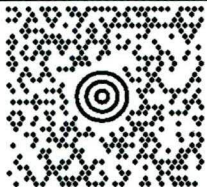

GA 309 0-01



UPS NEXT DAY AIR

1

TRACKING #: 1Z ASE 795 25 9710 9219



BILLING: P/P

Reference # 1: 07YXBPMDOC



JMLIGHT
8035575456
SAVANNAH RIVER NUCLEAR SOLUTIO
BLDG 731-1N RM 113
AIKEN SC 29808

1.1 LBS LTR

1 OF 1

SHIP TO:

LATASHA P. DENARD
9123584325
SAVANNAH STATE UNIVERSITY
2200 TOMPKINS RD
SAVANNAH GA 31404-5235

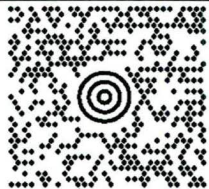

GA 314 8-04



UPS NEXT DAY AIR

TRACKING #: 1Z A5E 795 25 9807 2408

1

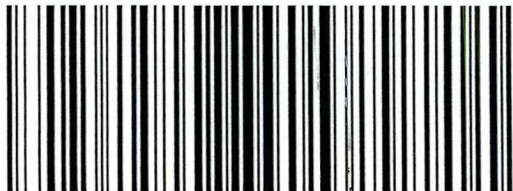

BILLING: P/P

Reference # 1: 07YXBPMDOC



JMLIGHT
8035575456
SAVANNAH RIVER NUCLEAR SOLUTIO
BLDG 731-1N RM 113
AIKEN SC 29808

1.1 LBS LTR

1 OF 1

SHIP TO:
MR. BILL SUDDUTH
8037775699
THOMAS COOPER LIBRARY
GOVERNMENT INFORMATION DEPT.
1322 GREENE STREET
COLUMBIA SC 29208-4002

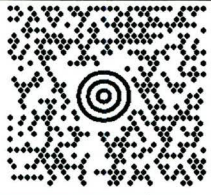

SC 292 9-01



UPS NEXT DAY AIR

1

TRACKING #: 1Z A5E 795 25 9161 7770

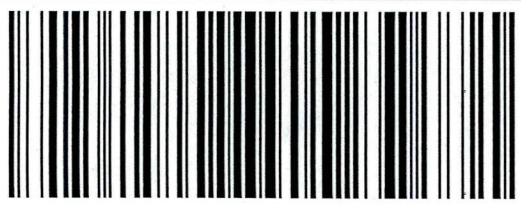

BILLING: P/P

Reference # 1: 07XYBPMDOC

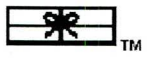

CS 22.0.12. WNTNV50-42.0A 01/2021*

Express Mail/Overnight Delivery Service Request

This form must accompany material to the mailroom.

To: Mail Room Personnel / Building 731-1N		Date 03/29/2021	
United Parcel Service (UPS)			
Service Required			
<input type="radio"/> AM Next Morning Before 10:30 <input checked="" type="radio"/> Next Business Day <input type="radio"/> 2nd Business Day <input type="radio"/> Saturday Delivery*			
Sender's Name (Print) Dexter McDaniel	Address 730-4B	Phone No. 2-7401	Speed Chart Code 07YXBPMDOC
Delivery Option*			
<input checked="" type="checkbox"/> Delivery Confirmation <input type="checkbox"/> Signature Required Declared Value of this Shipment is \$ <u>N/A</u>			
Security Classification			
<input checked="" type="radio"/> Unclassified <input type="radio"/> Official Use Only <input type="radio"/> UONI <input type="radio"/> Classified			
Destination Information			
Name/Company Ms. Susie O'Connor Gregg-Graniteville Library University of South Carolina Aiken		Street Address 471 University Parkway	
Phone Number 803-641-3261	City Aiken	State SC	Zip 29803
I certify that overnight delivery of <u>Industrial Wastewater Closure Module for F-Area Diversion Boxes 5 and 6 F-Area Tank Farm, Savannah River Site</u> (Title of Document or Description of Material) is necessary to comply with mission objectives and that no other method of forwarding is available or feasible to meet the required delivery deadline. This is Official Business material.			
NOTE: All <u>Classified Material</u> must be taken to the Classified Operations Group in 773-A. All <u>International Shipments</u> must be approved by Export Control located in Building 703-45A prior to shipping.			
APPROVALS			
COG Clerk Receiving Request (Print) <i>If Applicable</i>		COG Clerk Receiving Request (Signature) <i>If Applicable</i>	
Division Director/Manager Name - Level 4 (Print) <i>Chris Berger</i>		Division Director/Manager - Level 4 (Signature) <i>[Signature]</i>	

* Denotes Additional Fee Applies

110

JMLIGHT
8035575456
SAVANNAH RIVER NUCLEAR SOLUTIO
BLDG 731-1N RM 113
AIKEN SC 29808

1.1 LBS LTR

1 OF 1

SHIP TO:

MS. SUSIE O'CONNOR
8036413261
UNIVERSITY OF SOUTH CAROLINA AIKEN
GREGG-GRANITEVILL LIBRARY
471 UNIVERSITY PARKWAY
AIKEN SC 29801-6389

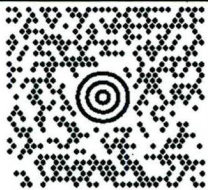

SC 298 0-01



UPS NEXT DAY AIR

TRACKING #: 1Z A5E 795 25 9063 8768

1

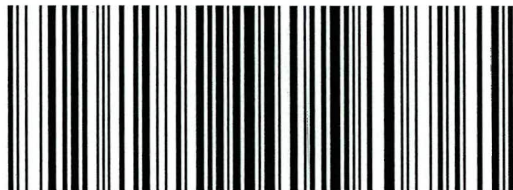

BILLING: P/P

Reference # 1: 07YXBPMDOC

